



RADIOWORLD

JUNE 17, 2015 | The News Source for Radio Managers and Engineers | \$5.00 | RADIOWORLD.COM



SIFTING 60 YEARS OF BROADCASTING

AAPB searches public radio/TV shelves for history to digitize.

Page 14

Photo courtesy of Lisa Aribbol

HD Radio Patent Case Dismissed

Broadcast groups appear off the hook; lawsuit cannot be reintroduced

NEWS ANALYSIS

BY RANDY J. STINE

A federal judge in Delaware has dismissed the long-running HD Radio patent infringement suit against 14 radio ownership groups after an apparent settlement. A related suit brought by HD Radio developer iBiquity Digital Corp. also was dismissed, suggesting a comprehensive but undisclosed resolution to this patent dispute.

Attorneys consulted for this article believe it is likely iBiquity's involvement was the catalyst for the most recent developments. However, they said it is impossible to determine exactly how the cases concluded without details of a possible agreement. The parties involved all have declined comment.

BACKGROUND

Wyncomm LLC and its subsidiary Delaware Radio Technologies LLC had filed the original suit in 2013, targeting the terrestrial HD Radio data and voice transmissions of the radio com-

panies. The patent firms sued in federal court, claiming the 14 broadcasters' HD Radio technology infringed on U.S. patent 5,506,866 and two associated patents that Wyncomm and DRT control.

Wyncomm and DRT said the '866 patent — "Side-Channel Communications in Simultaneous Voice and Data Transmission" — describes radio transmission techniques used in the in-band, on-channel digital radio broadcasting standard adopted by the National Radio Systems Committee in 2005. The suit appeared to attempt to tie the NRSC standard to HD Radio specifically, though NRSC-5 describes IBOC as a generic term that could apply to any such system from any proponent.

The broadcasters named as defendants in the federal lawsuit were Beasley

Broadcast Group, CBS Radio, CC Media Holdings (now iHeartMedia), Cox Media Group, Cumulus Media, Entercom, Entravision, Greater Media, Hubbard Radio, Radio Disney, Radio One, Saga, Townsquare Media and Univision.

The judge acted after the parties requested dismissal and agreed to cover their own costs, expenses and attorneys' fees, according to court documents. The Wyncomm suit was dismissed with prejudice, meaning it cannot be reintroduced in any court of law, according to legal observers.

These developments coincide with dismissal of a separate suit in the same court that iBiquity filed in 2014 against Wyncomm and DRT, claiming the patents were invalid and that iBiquity had

(continued on page 10)

It's Music Disc-covery at Milwaukee's WMSE

This station doesn't just love vinyl, it *makes* vinyl

BY STEPHANIE KILEN

MILWAUKEE — Live performances and recordings have long been an integral part of the format here at Milwaukee's WMSE(FM). For the annual Record Store Day, the station has married this popular aspect of our offerings and identity with another of its long-standing traditions: vinyl.

On April 18, WMSE released the 7-inch single "Live From the WMSE Studios: Field Report." The release

features a unique venture and mutual celebration between Chris Porterfield of the band Field Report and WMSE; it also shines light on the work the station's recording engineer Billy Cicerelli produces on a regular basis.

In his 16 years at the station, Cicerelli estimates he has recorded 2,000 live band performances and countless more over his 30-year career. He believes it takes a balance of technology and human touch to

(continued on page 26)

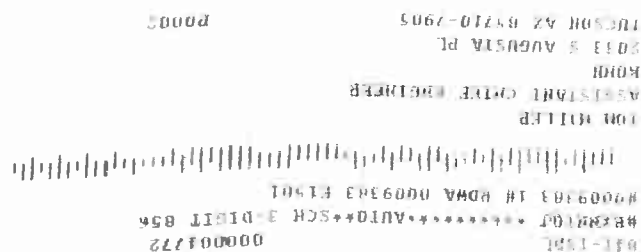

The Future of Automation Is

NOW



ENCO

ENCO.COM

Broadcast Audio Processing Perfectionist?

IF SO, WE'VE GOT SOME REALLY COOL STUFF TO SHOW YOU.

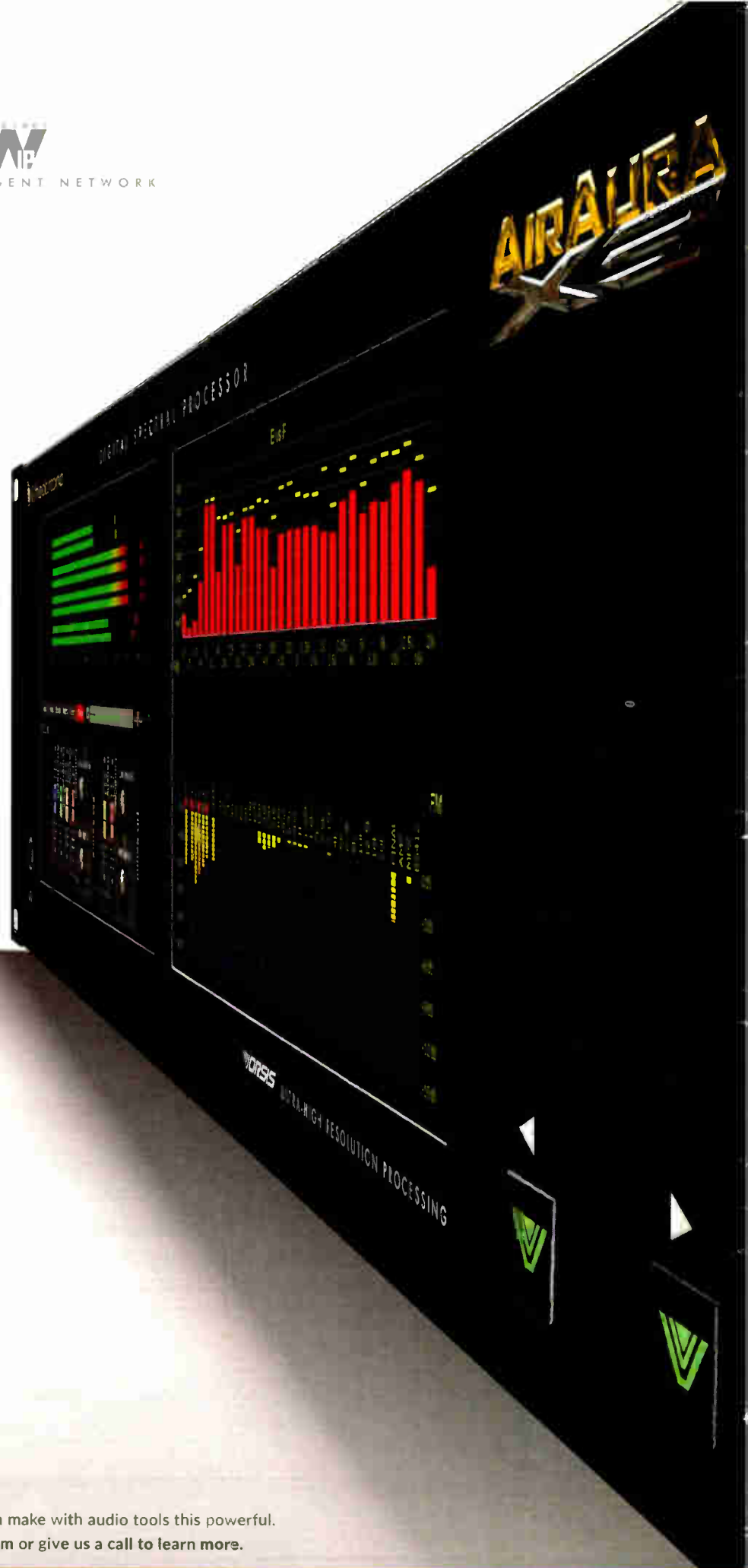
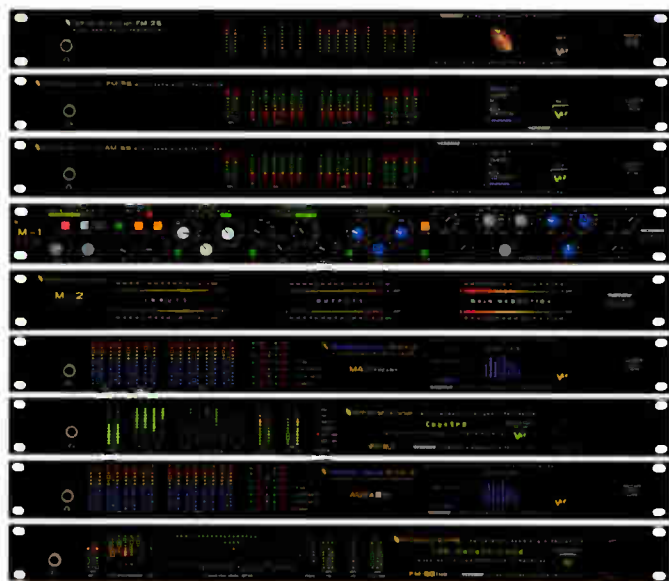

Wheatstone gives you the power to sculpt perfect clarity, loudness, and sweetness with absolute precision – the sound you've always heard in your head, but couldn't quite get with traditional processors.

- SST (Sweet Spot Technology) can invisibly manage spectral balance and program density to create a truly natural and superior listening experience.
- Wheatstone's 31-band Limiter lets you dig into any audio and give it the volume your audience demands without introducing perceived distortion. It virtually eliminates listener fatigue.
- Bass Tools go right for the gut. They process on a side-chain and let you dial in exactly what you choose to put back into the mix.
- Multipath Limiter can help remedy multipath blend in car stereos by reducing excessive L-R (difference) transmission.
- Baseband 192 keeps your signal chain pristinely digital – from input straight out to your exciter or transmitter.

Of course, it all comes together seamlessly to deliver the finest audio you can imagine.

Think about the difference YOU can make with audio tools this powerful.
Visit perfection.wheatstone.com or give us a call to learn more.

 **Wheatstone**
BROADCAST AUDIO PERFECTIONISTS®

phone 1.252.638-7000 | wheatstone.com | sales@wheatstone.com

World Radio History

For address changes and subscription renewal, please visit radioworld.com and click on the "Subscription" button. To submit letters or story proposals, to request writer's guidelines, or for other editorial matters, email the editor at radioworld@nbmedia.com.

EDITORIAL STAFF
EDITOR IN CHIEF, U.S. Paul J. McLane
NEWS EDITOR/WASHINGTON BUREAU CHIEF Leslie Stimson
GEAR & TECHNOLOGY EDITOR Brett Moss
TECHNICAL ADVISER Thomas R. McGinley
TECHNICAL EDITOR, RWEE Rich Rarey
PRODUCTION EDITOR, RWEE Karen Lee
CONTRIBUTING EDITOR Emily Reigart
CONTRIBUTING EDITOR John Bisset
INTERNATIONAL EDITOR IN CHIEF Marguerite Clark
LATIN AMERICA EDITOR IN CHIEF Rogelio Ocampo

EDITORIAL CONTRIBUTORS
W.C. Alexander, James Careless, Hany Cole, Ken Deutsch, Mark Durenberger, Charles Fitch, Christopher Friesen, Harold Hallikainen, Craig Johnston, Alan Jurison, Paul Kaminski, John Kean, Peter King, Mark Lapidus, Daniel Mansergh, John Merli, Laura Mir, Jim Peck, Mark Persons, Stephen M. Poole, Carl Lindemann, James O'Neal, Tom Osenkowsky, Rich Rarey, John Schneider, Randy Stine, Richard Strickland, James G. Withers, Tom Vernon

ADMINISTRATION & PRODUCTION
PUBLISHER John Casey
EDITORIAL DIRECTOR Paul J. McLane
PRODUCTION DIRECTOR Davis White
PRODUCTION PUBLICATION COORDINATOR Karen Lee
ADVERTISING COORDINATOR Caroline Freeland

CIRCULATION
GROUP DIRECTOR, AUDIENCE DEVELOPMENT Meg Estevez
CIRCULATION MANAGER Kwentin Keenan
ASSOCIATE CIRCULATION MANAGER Michele Fonville

SUBSCRIPTIONS
Radio World, P.O. Box 282, Lowell, MA 01853
TELEPHONE: 888-266-5828 (USA only 8:30 a.m. - 5 p.m. EST)
978-667-0352 (Outside the US) FAX: 978-671-0460
WEBSITE: www.myRWNews.com
EMAIL: newbay@computerfulfillment.com

CORPORATE
NewBay Media LLC
PRESIDENT AND CEO Steve Palm
CHIEF FINANCIAL OFFICER Paul Mastronardi
CONTROLLER Rick Ng
VICE PRESIDENT OF AUDIENCE DEVELOPMENT Denise Robbins
VICE PRESIDENT OF DIGITAL MEDIA Robert Ames

VIDEO/BROADCAST GROUP
EXECUTIVE VICE PRESIDENT Carmel King
VICE PRESIDENT / SALES DIRECTOR Eric Trabb

ADVERTISING SALES REPRESENTATIVES
US REGIONAL & CANADA: John Casey, jcasey@nbmedia.com
T: 212-378-0400, ext. 512 | F: 330-247-1288
US REGIONAL: Michele Inderrieden, minderrieden@nbmedia.com
T: 212-378-0400, ext. 523 | F: 301-234-6303
EUROPE, AFRICA & MIDDLE EAST:
Raffaella Calabrese, rcalabrese@nbmedia.com
T: +39-320-891-1938 | F: +39-02-700-436-999
LATIN AMERICA: Susana Saibene, susana.saibene@gmail.com
T: +34-607-31-40-71
JAPAN: Eiji Yoshikawa, callems@world.odn.ne.jp
T: +81-3-3327-5759 | F: +81-3-3322-7933
ASIA-PACIFIC: Wengong Wang, wwg@imaschina.com
T: +86-755-83862930/40/50 | F: +86-755-83862920
CLASSIFIEDS: Michele Inderrieden, minderrieden@nbmedia.com
T: 212-378-0400, ext. 523 | F: 301-234-6303
LIST RENTAL: 914-925-2449, danny.grubert@lakegroupmedia.com

Radio World Founded by Stevan B. Dana

Radio World (ISSN: 0274-8541) is published bi-weekly with additional issues in February, April, June, August, October and December by NewBay Media, LLC, 28 East 28th Street, 12th Floor, New York, NY 10016. Phone: (703) 852-4600, Fax: (703) 852-4582. Periodicals postage rates are paid at New York, NY 10079 and additional mailing offices. POSTMASTER: Send address changes to Radio World, P.O. Box 282, Lowell, MA 01853.

For custom reprints & eprints please contact our reprints coordinator at Wright's Media: 877-652-5295 or NewBay@wrightsmedia.com

Globe graphic ©iStockphoto.com / Edward Grajeda

Copyright 2015 by NewBay Media, LLC.
All rights reserved.
Printed in the USA



A Day With Sangham Radio

What can be learned when one listens to rural Indian women talk about technology?

FIRSTPERSON

BY PETE TRIDISH

ZAHEERABAD, INDIA — During a recent technical survey of community radio in India conducted by my organization, International Media Action (www.imarad.io), I was invited to visit Sangham Radio. This station in Zaheerabad, owned by the Deccan Development Society (<http://ddsindia.com/www/radiostn.htm>), was the first community radio station to go on the air in India, in October of 2008.

The society has some 6,000 members, who earn their living as laborers and farmers. All pay 50 rupees per year (about US\$1) to support the radio station. All are part owners of the station. The 6,000 members of the society are Dalits, the lowest Hindu caste, which was once called "untouchable." While discrimination based on caste is now illegal, it is still pervasive in Indian society. Since most land and wealth in India was acquired under conditions of legal discrimination, most Dalits today continue to do the worst jobs, and most live in poverty.

RADIO'S IMPORTANCE

The women from the sanghams (women's collectives) make lots of videos about issues of importance to them. Even though many are illiterate, a number of the women have become quite accomplished with audio and video

recording and production. But, as they learned to use it, they felt that they made much better videos and audio reports themselves than the ones made by outsiders. (Reflecting on this, please understand that I am paraphrasing the translations of what the women said to me while I was there, rather than trying to recreate their exact words.)

Just about all programming is pre-recorded, and then edited before going on air. The station records two hours

tioned that most groups where I come from play their stations 24 hours a day, with little more effort and great convenience for listeners who are sometimes busy when a favorite program is on the air.

We asked the women about this, and their disinterest in the idea was immediate. "We all work all day in the fields; we don't listen to radio there. We need to talk, plan, make decisions, and sing together in the fields," they said. "We would not want to displace all those community hours together being entertained by a radio, like passive consum-



Kanchan K. Malik

The author works with the Sangham Radio staff in the Indian state of Telangana.

Listeners give radio their full attention in the evenings so they can "learn important new things."

When the women started, they were intimidated by all of the equipment. They described the perceived difference between when they make videos or audio reports versus the ones made by outsiders. Outsiders come with all the shots planned out and a few words they want the women to say, all decided before the filmmaker even arrives. Then when the video is finished, it seems like the women had made the filmmakers point.

When the women started, they were intimidated by all of the equipment.

of programming per day. They do no live shows, and they take no syndicated content.

During this sort of visit, since radio engineers do not often visit stations like this, I typically do as much troubleshooting as I can. We looked at issues with their transmitter power output, their transmission lines, and lightning protection, all of which the group was anxious to improve. I also remarked in passing that with the existing equipment, it would be quite easy to repeat shows later in the day, or replay certain "evergreen" programs or music. I men-

ers. We listen to radio in a focused time in the evenings when we need to learn important new things, and we give it our attention then."

CHOICE

This answer gave a unique window upon their views on technology, and even more than that it gave me a mirror to look at my own cultural attitudes and assumptions. It was striking that they took the radio so seriously and paid full attention to it.

In my world, radio is what you listen to when you are doing something else boring, like driving, cooking, cleaning, working. And even more striking: For people in wealthy countries, so much of our relationship to technology is that it is an inexorable force that we must keep up with, whether it does us any good or not. The concern for displacing our social relations with passive entertainment is

(continued on page 5)

Unique, Compelling, Locally Produced

Don't surrender the advantages you have in your brand and your local identity

Promote your brand every day. And emphasize your local advantage.

Those are steps to success for today's radio station. The lessons are on my mind after a recent chat with the leader of a prominent mid-size group. I asked him to reflect on the turbulence in commercial radio over the past few years and the prospects for his company.

Radio revenue, he said, has been struggling to come back from the "disaster" of 2008 and 2009 as our industry sailed into the headwinds of a less robust economy, lower consumer confidence, lower retail sales and an explosion of digital advertising options — factors that confront all legacy advertising media, not just radio.

"It's more of a struggle every day to generate revenue, particularly on the regional/national front, the transactional/CPM-based stuff," he said, though selling is not quite as difficult in direct relationship-based work. "What keeps me up at night is how to drive revenue and get beyond these limitations. It's been a lot tougher."

Should broadcasters be maxxing out their investment in digital platforms



iStockphoto/Vagengeym_Elena

Digital natives want good music and local information, just like other demos. Are you giving it to them?

right now?

ONLINE VALUE

His group has been active online since 1993. It has been streaming for 20

years and created an interactive division in 2002. "We generate up to 20 percent of our revenue through interactive and digital, so we recognize the value. We think you need to be there," he said.

FROM THE EDITOR



Paul McLane

Yet the role of digital advertising, he continued, has yet to be understood fully. Advertisers may *think* they're getting good returns, but are they? "We know log-on time, where they went, what they clicked on ... but that doesn't mean there's any reaction to it."

He emphasizes three points to keep in mind when managing radio in 2015. He was speaking about his own approach but the lessons might apply to any U.S. commercial station:

- Your strategy needs to be about your brand. It must remain strong. The brands of his lead AM/FM stations "are still as strong as any digital competitor," he said, which is true of thousands of radio stations in the country. So the question when considering any digital platform becomes, "How do we create value in these brands via new channels?"

- So Pandora is knocking on the doors of car dealers? His pitch to local advertisers: "You knew us yesterday, you'll

(continued on page 6)

So many consoles, products and platforms all support the StudioHub+ plug-and-play solution for fast and easy integration.

StudioHub+ inside



Radio Systems, Inc • 601 Heron Drive, Logan Township, NJ 08085 • 856-467-8000 www.studiohub.com



THIS ISSUE

JUNE 17, 2015

NEWS

HD Radio Patent Case Dismissed.....	1
A Day With Sangham Radio.....	3
Unique, Compelling, Locally Produced.....	4
Taking a Closer Look at PPM.....	6
News Roundup.....	5, 8, 10

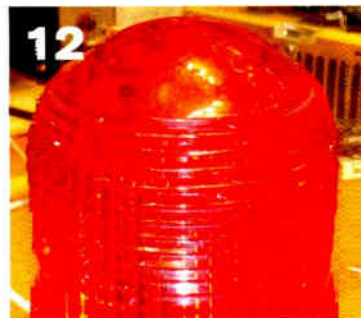
**FEATURES**

Spread That Paperwork Around.....	12
AAPB Digitizes 60 Years of Public Broadcasting.....	14
What to Expect When You're Expecting an LPFM.....	18
Your Data Is, Well, Your Data.....	20
Follow That Space Station!.....	21
My Love Affair With an Ampex Recorder.....	22



Photo via John Schneider. Courtesy Mike Adams from the Jack Russell Wagner photo archive

GM JOURNAL

Sales Folks, Let's Get Back to Basics.....	23
Find the Road Home for Success.....	24

STUDIO SESSIONS

It's Music Disc-covery at WMSE.....	1
-------------------------------------	---

OPINION

Reader's Forum.....	29, 30
---------------------	--------

NEWSROUNDUP

FCC: Leaders of the House Energy and Commerce Committee announced an agreement June 9 with Federal Communications Commission Chairman Tom Wheeler to amend plans to close Enforcement Bureau Field Offices.

"The revised plan will keep 15 of the FCC's 24 field offices open, ensure better rapid response capabilities for the west, provide a mechanism for escalating interference complaints, improve enforcement of the FCC's rules against pirate radio operators and prevent the commission from transferring field office jobs to the FCC's Washington, D.C., headquarters," the lawmakers said in a statement.

The Subcommittee on Communications and Technology also cancelled a hearing on the "Oversight of FCC Field Offices" that had been slated for June 11, which was intended to address concerns about the closures.

In March, the news broke that the commission was planning to close as many as 16 of its 24 field offices, and reduce the number of field agents from 63 to 33.

"Today, I circulated to my fellow commissioners a modified plan to modernize our field offices," Wheeler said in a statement on the commission's website. "These changes create the opportunity for the FCC to be more efficient with its resources while actually improving 21st-century field activities. The updated plan represents the best of both worlds: rigorous management analysis combined

with extensive stakeholder and Congressional input."

Wheeler went on to thank the lawmakers as well as the National Association of Broadcasters for their input in crafting the proposal. He then urged his colleagues "to approve this revised plan with dispatch."

The announcement did not address whether the number of field officer positions would be reduced in the amended proposal. An FCC spokesperson told Radio World in an email that they could not discuss the issue further until the commissioners had finished deliberating.

"Communities across America will continue to be served even as the commission becomes more efficient," full Committee Chairman Fred Upton (R-Mich.) said. "It also demonstrates how much we can accomplish when we work together to tackle the many tough issues we face."

"These changes will keep field offices open in strategic locations and help ensure that the commission can fulfill its responsibilities to the public and public safety communities," said Communications and Technology Subcommittee Chairman Greg Walden (R-Ore.). "This agreement strikes a balance between the important work of FCC field agents and streamlining field operations to ensure the efficient use of taxpayer dollars."

The NAB also weighed in: "NAB thanks the many members of Congress who expressed concern over proposed cuts in FCC field offices, and we applaud Chairman Wheeler and his staff for resolving this issue in a manner that better protects against airwave interference."

SANGHAM

(continued from page 3)

so far past for us, it is almost invisible. The Dalit women's experiences with agribusiness, the Bhopal gas disaster and "development" schemes have made them more circumspect in adopting technologies which experts push. Their critical analysis has a level of scrutiny beyond what most Westerners today are capable of, and their resolve to make technology work for the outcomes they choose is impressive.

I certainly could imagine reasonable arguments for other approaches to repeats of their broadcast, but next time some hyped up new technology comes along that I have to adopt, I will think of these women and how they feel that the choice is truly their own to make.

Learn more about the Hyderabad-based Deccan Development Society radio station from their website. It includes a number of very thought-provoking quotes from these women, fewer than 10 percent of whom are literate. To read an outline of a typical radio program broadcast on the station, visit <http://ddsindia.com/www/undp.htm>.

For information on the work of the UNESCO Chair for Community Media, which arranged my visit, including their Continuous Improvement Toolkit for Community Radio, see: <http://ucommmedia.in>.

Pete Tridish, based in Philadelphia in the United States, is the chief engineer at International Media Action, a nonprofit community radio engineering crew.

You can't close your ears, so close your eyes and enjoy the music.



BROADCAST | NETWORKED AUDIO | INSTALLED SOUND

AUDIO IS OUR SCIENCE.

For more info, call +1-302-324-5333 or email salesasi@audioscience.com.



www.audioscience.com

Taking a Closer Look at PPM

Can audio processing help your station count?

BY MICHAEL LECLAIR

The possible effects of audio processing on Portable People Meter measurements were the topic of two presentations at the NAB Show Broadcast Engineering Conference this spring.

Cornelius Gould, senior algorithm developer for Telos Alliance, introduced the subject with a discussion of the concepts behind watermarking. Dr. Barry Blesser followed up with a presentation that delved more deeply into the technology behind watermarking and potential weak points that he said may cause some stations to underperform with this form of measurement.

Both discussed the background for development of the Voltair, an audio monitoring product from 25-Seven Systems, which is part of Telos. The company says its product can assist stations in determining how to process their audio programming for best performance with embedded audio watermarks. Both Gould and Blesser said that they have no specific knowledge of Nielsen's watermarking technology and that Telos Alliance and Nielsen were working cooperatively to determine what effects, if any, the Voltair has on Nielsen's PPM measurement system.

HIGH PROFILE

There are 48 radio markets in the United States that obtain ratings estimates via Nielsen's PPM system. They include the nation's largest markets. Diaries are still used in the majority of close to 300 radio markets; respondents report their listening habits during a sample week in a given market.

Under the diary, stations realized it was important to provide a high profile to their identity on-air. Announcers were required to give out a recognizable station ID and call letters at every opportunity, according to Gould.

For stations being measured with PPM, a representative watermark can be detected via an electronic monitor worn by a listener. The watermark is designed to be inaudible to listeners so that it does not interfere with the audio.

While the primary determinant of

listenership is going to be good radio programming, under PPM it is also important to ensure the electronic monitor operates

To keep the watermark inaudible, the PPM encoder will not add it to the program audio unless its internal masking algorithms determine it will not be heard, according to Gould. As



Experiments that Improve Watermarking

Some "trial and error" experiments:

- Equalization of program content.
- Extra gain riding in front of the watermark encoder.
- Extra multiband gain riding before watermark encoder.
- Reverberator in front of the watermark encoder.

Images courtesy of Telos Alliance

Telos Alliance Senior Algorithm Developer Cornelius Gould said there have been a number of attempts by various experimenters to try to format and process radio programs to achieve the same benefit as verbal repetition of station ID and call letters.

to capture this "inaudible" watermark accurately; otherwise a potential listener may not be counted, Gould said.

To remain inaudible, the watermark technology relies on the concept of audio masking, according to Gould. He compared the watermark to a needle in the haystack of an audio signal. The PPM monitor, designed to extract needles, is able to locate the audio watermark, while humans listening are unable to discern it within the larger stack of audible information in a radio program.

an extreme example, during silence the encoder has no audio available for masking and it will not be able to insert any watermarks because there is no haystack under which to hide the needle, he said.

HELP NOT HURT

In the PPM era, he said, there have been a number of attempts by various experimenters to try to format and process radio programs to achieve the same benefits that verbal repetition of station ID and call letters did for diary reports.

BRAND

(continued from page 4)

know us today, you'll know us tomorrow. Those people are carpetbaggers; they don't know your market." None of the large digital/satellite non-local competitors, he said, has effectively created a product and strategy that supplants the unique, compelling, locally-produced-and-delivered content that his stations provide.

• The "VCR flashing 12" theory: Consumers still want simplicity, whether it's in their coffeemakers or their car's digital dashboard. When it comes to new technology, "the real world is still trying to figure out how to use it, and knows how easy it is to turn on a radio... something that's familiar, easy to use and doesn't require enough bars on your cellphone ... I think people gravitate to that." This is so even with digital natives, who by the way, also still want and need local information.

True, many stations, he said, are worried about survival day by day; and he feels that often, trade press focuses too much on large public companies that have significantly different priorities than do smaller companies operating in medium and small markets. "When it gets to the market level

Diary-oriented techniques offer no benefit in the presence of an electronic monitor that automatically identifies the station; such formatics could actually impair the PPM results, he said.

Concepts tried by stations have included the elimination of voice breaks without music underneath, the use of reverb, the use of specialized automatic gain control in the band of frequencies used by PPM, and even equalization of station audio in an effort to provide just the right "contour" that would allow the PPM monitor to respond, Gould said. These attempts basically were guesses, limited by the lack of a measurement tool that could provide a real-time answer as to whether they had any effect, Gould said. That lack of certainty, according to the Telos Alliance, led it to investigate the possibility of developing such a tool.

It used environmental monitoring to simulate the effects of listener location on the effectiveness of watermark detection in the presence of background noise, such as a car being driven at 65 miles per hour or in a kitchen with television programs in the background, combined with other household noises such as cooking or cleaning. From this research came the Voltair processor, now being offered by 25-Seven. It is designed to quantify in real time the environmental impacts on watermark detection as well as the effects of changes in the audio processing, Gould said.

Telos concluded that audio processing could, in fact, affect the performance of the PPM encoder. Initially, Nielsen client stations were instructed to insert their watermark encoding at a convenient line-level input in the radio station audio chain. But Telos recom-

(continued on page 8)

on which we operate, they take a different approach, a 'scalable' approach that we can't use."

But while the march of technology may be quicker than many thought, "AM radio signals from towers are going to be viable for 10 years or more; longer for FM signals. Meantime we're integrating our brand into these other media."

The biggest challenge, he said, is for stations to recognize what should be their strength — "We're here in your market, your hometown, we are you. We shop in the same stores, our kids go to the same schools" — while balancing that with a need to build platforms and channels to deliver their brand.

A key part of the radio marketing process, he said, is to use all means at your disposal — social, retargeting, digital as well as traditional marketing, right down to direct mail, events and billboards. "Determine what the best channels are, and do it." Talk your medium up. Everyone hears about how great Pandora or Spotify is; radio stations need to advocate their position. Stations too often tell others to spend on marketing but don't do it themselves. Don't give up your brand; just figure out how to most effectively deliver it. Work those traditional channels in the meantime.

So: Promote your brand every day. And emphasize your local advantage.

"If you want someone to use your product, create a product that's unique, tell them it's there, give 'em incentive to use it and tell them how much you love 'em."

8 of the **TOP 10** U.S. radio stations are Nautel customers.

nautel.com nautel

WHERE COULD YOU GO...

...IF YOU HAD
ACCESS?

NEED ACCESS?
CONTACT US:

1 800 237 1776
info@comrex.com

COMREX
BROADCAST RELIABLE

www.comrex.com

◀ **ACCESS** ▶
2USB

WIRELESS CODEC FOR AUDIO OVER IP

VOLTAIR

(continued from page 6)

mends using multi-band AGC before the encoder, which it says provides more opportunities to mask a watermark.

MASK VS. DECODER

In a separate session, Dr. Barry Blesser, director of engineering for 25-Seven, provided a more technical presentation of the details of audio watermarking. (Blesser prefaced his comments by saying they concerned watermarking systems in a general way but had no specific reference to the precise details of the watermarking system employed by Nielsen in its PPM system.)

Blesser said that in order for stations to record successful ratings estimates, both channels of a two-channel communication system are required to perform well.

To ensure that 100 percent of all the transmitted watermarks are received by monitors, stations can transmit a signal with watermarks at audible levels, but the resulting tones on top of audio with tones mixed in is unlistenable, and the station will not attract many listeners to measure, he said. Conversely, stations may have a large number of listeners attracted to their programming, but without good operation of the monitoring channel, their ratings estimates will suffer and few advertisers will believe them, he concluded.

In general, watermarking consists of a series of tones of changing frequency that carry some form of data. For Blesser, the key is whether sufficient audio energy exists to mask the intended watermarks properly without truncating important information. For example, in a typical watermarking system, tone duration will

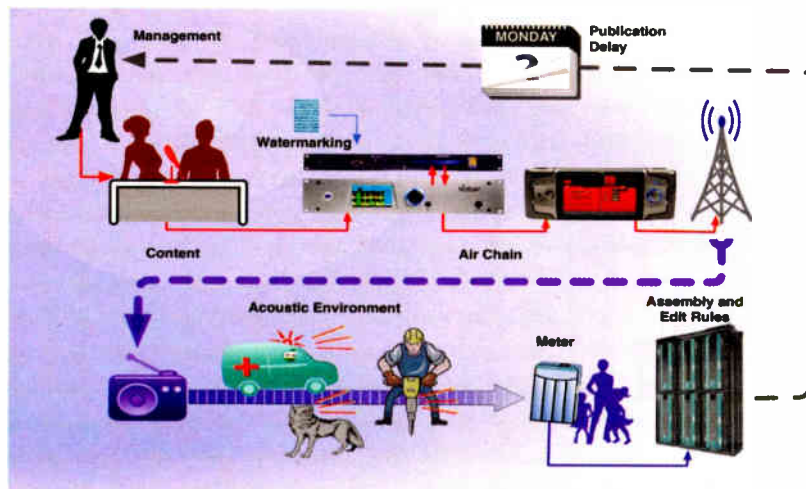

Telos used environmental monitoring to simulate the effects of listener location on the effectiveness of watermark detection in the presence of background noise.

need to run about 400 milliseconds to allow a clean and clear decoding of the tone. If this tone is partially truncated, to perhaps 100 milliseconds, the result is a much lower signal-to-noise and a blurring of the line that determines which data tone is being fed. Tones truncated shorter than 25 milliseconds are undecodable, no matter what kind of signal processing is used, according to Blesser.

A problem arises in real-world watermarking systems that rely on masking to hide the watermark tones, he argued. There is no way to predict if the program audio will have sufficient energy to mask a watermark for the entire tone length, and indeed there are some kinds of audio programming that when examined do not provide the correct energy in the key watermarking spectrum, he said. One way to help mitigate this problem is massive repetition of the watermark signals to increase the chance that uncorrupted

signals reach the intended monitor, but there is no guarantee that will work.

of the audio and the encoder output, but it is not able to tell the user precisely what will be received at a PPM monitor.

How can the Voltair be used to determine how a given change in program processing could affect PPM ratings estimates? Blesser suggested using a technique that varied an element, such as the settings of an audio processor, between two levels on odd and even minutes.

Statistically, the results should be reasonably consistent, since the number of samples at similar dayparts and times would be sufficient to characterize the system performance once the audience estimates are available, typically in three weeks.

After analysis, the change in audience estimates between these two settings

For Blesser, the key is whether sufficient audio energy exists to mask the intended watermarks properly without truncating important information.

MEASURE AND FINE TUNE

The development of the Voltair was an attempt to help understand how watermarking is affected by different types of program material. Blesser emphasized that the Voltair is an emulation of a watermarking system but that it does not employ any of the technology or intellectual property of the PPM system.

The Voltair can perform observations

(if any) allows the station to predict to what degree further, and perhaps more drastic, changes in processing will do to the ratings, based on a linear extrapolation of the results of the two different program settings, according to Blesser. Essentially, the Voltair allows stations to numerically measure the effects of changes to an emulated watermarking system in order to fine-tune its operation.

The author is manager of broadcast systems at WBUR(FM), Boston, and a longtime Radio World contributor.

NEWSROUNDUP

EAS: The FCC has established operational standards to be used during tests and actual emergencies. The changes were guided by what was learned in the first national EAS test in 2011. The commission adopted "000000" as the national location code and will require stations to use equipment that can process the location code and a National Periodic Test event code for future nationwide EAS tests. Stations will need to file test data electronically using the FCC's Electronic Test Report System. EAS participants must comply within 12 months of the new rules' effective date.

REGULATORY FEES: The FCC predicts it will collect nearly \$400 million in regulatory fees in FY 2015, the same as FY 2014 and the previous three years. Of that, just over \$28 million comes from radio and \$23.6 million from TV broadcasters. Commercial radio stations paying regulatory fees outnumber commercial TV stations: 10,226 to 4,754. For radio, fees range from the lowest at \$775 for a Class A in the smallest markets to \$12,025 for FM Classes B, C, C0, C1 and C2 in the largest markets. Noncoms are

exempt. Effective this year, regulatory fees on Broadcast Auxiliary licenses have been eliminated.

REG FEES CHANGES: The FCC sets the fees it collects from each industry according to how many commission employees are involved in regulating that service. In a Notice of Proposed Rulemaking, the agency asked whether it should reexamine the number of people devoted to regulating radio versus TV and adjust the fee for each "to more accurately take into account" the time spent on each service. Currently, TV fees are based on market rank while radio remains assessed by population size and station class. The agency

asks whether radio fees should be calculated like TV, noting that may provide radio stations "more stability and predictability." After reviewing the public comments, the FCC will release an order, likely this summer, with the final 2015 fee amounts and establish a filing window for September. Any changes made to the broadcasters' assessments are not likely to apply to this year's fees. Comments to Docket 15-121 are due June 22 and replies on July 6.

FY 2015 RADIO STATION REGULATORY FEES						
Population Served	AM Class A	AM Class B	AM Class C	AM Class D	FM Classes A, B1 & C3	FM Classes B, C, C0, C1 & C2
<=25,000	\$775	\$645	\$590	\$670	\$750	\$925
25,001 – 75,000	\$1,550	\$1,300	\$900	\$1,000	\$1,500	\$1,625
75,001 – 150,000	\$2,325	\$1,625	\$1,200	\$1,675	\$2,050	\$3,000
150,001 – 500,000	\$3,475	\$2,750	\$1,800	\$2,025	\$3,175	\$3,925
500,001 – 1,200,000	\$5,025	\$4,225	\$3,000	\$3,375	\$5,050	\$5,775
1,200,001 – 3,000,000	\$7,750	\$6,500	\$4,500	\$5,400	\$8,250	\$9,250
>3,000,000	\$9,300	\$7,800	\$5,700	\$6,750	\$10,500	\$12,025

AUDIO WITHOUT COMPROMISE



ROCK SOLID STL CONNECTIONS.

- POINT-TO-POINT 24 BIT 96 KHZ STEREO AUDIO SAMPLING
- DUAL GIGABIT ETHERNET PORTS ENABLING DUAL PATH DIVERSITY
- TIELINE'S PROVEN SMARTSTREAM IPV4/IPV6 IP TECHNOLOGY
- DUAL REDUNDANT BACKUP POWER SUPPLIES
- AUTOMATIC NETWORK AND AUDIO BACKUP

CONTACT TIELINE OR YOUR DEALER TODAY



1-317-845-8000

www.tieline.com/genie

HD PATENT*(continued from page 1)*

“prior art” to prove it.

iBiquity licenses the HD Radio technology to broadcasters; court records show that iBiquity had asserted that it had a “contractual obligation to indemnify” the broadcasters. The judge had agreed, stating earlier: “The court is ... convinced by iBiquity’s showing that a contractual indemnity obligation existed as to at least some, if not all, of the broadcast defendants.”

The indemnity clause suggests that a settlement — if one was reached — would have been between iBiquity and the patent holders, according to observers.

Court documents indicate iBiquity’s suit was dismissed at the request of the parties by U.S. District Court Judge Gregory Sleet without prejudice in early May. A dismissal “without prejudice” leaves the parties free to litigate the matter in a subsequent action, observers said.

POSSIBLE SETTLEMENT?

“It is very likely that iBiquity reached some settlement with Wyncomm,” said Scott Daniels, an intellectual property attorney with Westerman, Hattori, Daniels & Adrian LLP, who is not part of the case but has been following developments.

He said that Wyncomm and DRT “obviously went to enormous expense to sue so many accused infringers, they must have had an enormous incentive to stipulate the dismissal of those cases, either a generous royalty or a strong argument by iBiquity that the patents were invalid or not infringed.”

Daniels, who heads the firm’s litigation department, said if there was a

settlement, it does not appear to have been disclosed to the judge.

“It’s customary for the parties to withhold details of a settlement [from the judge],” Daniels said. “The court is typically just pleased to remove the case from the docket.”

The fact that Wyncomm and DRT’s claims were dismissed with prejudice while iBiquity’s claim was dismissed without suggests that the presumed settlement was favorable to iBiquity.

reclaims by both Wyncomm and iBiquity signals a settlement of some sort.”

Ragland, who is not involved with the HD Radio case, said he can’t tell what the terms of the presumed settlement are from the dismissal papers filed with the court. “We really don’t know whether there is money flowing in either direction.”

Once Wyncomm’s request to dismiss iBiquity’s declaratory judgment was denied and the judge consolidated and stated the broadcasters’ cases, it was

Wyncomm and iBiquity did leave open the possibility of future litigation between themselves over the patents, but at least for now the case is over.

— Bill Ragland, Womble Carlyle Sandridge & Rice

according to Daniels. He declined to speculate further without knowing details of any arrangement.

But broadcasters likely have iBiquity to thank for the conclusion of their cases, Daniels said, since Wyncomm’s suit against the broadcasters was likely weakened after iBiquity filed its suit.

“It’s even possible that Wyncomm let the cases and patents go for nothing at this point, especially if it appeared iBiquity had the prior art,” Daniels said. He doubts iBiquity would have engaged the case if its plan “was to enter settlements favorable to the patentee.”

Bill Ragland, an intellectual property litigator with Womble Carlyle Sandridge & Rice, said, “The fact there was a voluntary dismissal of all claims and coun-

probably a good time to begin settlement talks, Ragland said.

“Wyncomm and iBiquity did leave open the possibility of future litigation between themselves over the patents, but at least for now the case is over,” Ragland said.

Even though the lawsuits did not progress very far, the “legal expenses nonetheless could have been still been significant” for broadcasters, Ragland said.

Observers describe Delaware-based Wyncomm and DRT as patent-holding companies and “non-practicing entities,” meaning the companies neither manufacture a product nor provide a service. Wyncomm and DRT have aggressively defended the patents. They also sued

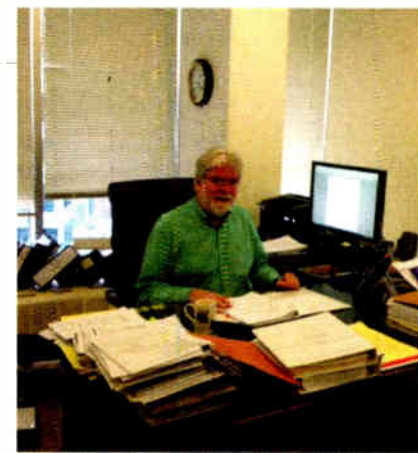

Intellectual property attorney Scott Daniels of Westerman, Hattori, Daniels & Adrian said if there was a settlement, it does not appear to have been disclosed to the judge.

nearly 20 large auto manufacturers over the HD Radio technology used in their cars citing patent ‘866. Those suits were dismissed in similar fashion in late 2014.

iBiquity addressed those auto patent infringement complaints in its filing against Wyncomm. The HD Radio developer wrote in the documents: “iBiquity has a contractual obligation to indemnify the broadcasters and suppliers to the car manufacturers against any losses incurred as a result of being sued over their use of HD Radio technology.” Ragland said it is not uncommon for vendors, in this case iBiquity, to stand behind their products if they become embroiled in lawsuits.

All along iBiquity pushed forward the argument that patent ‘866 and the others were invalid, according to court documents. “Had the patent examiner known or been made aware of prior art references, the claims would not have been allowed and the ‘866 patent would not have issued,” according to iBiquity’s court filings. The original patent holder was AT&T Corp.

NEWSROUNDUP

FCC: The House Energy and Commerce Committee sent the FCC Process Reform Act to the full House of Representatives for its consideration. Sponsored by Communications and Technology Subcommittee Chairman Greg Walden (R-Ore.) and Rep. Adam Kinzinger (R-Ill.), supporters say the measure will bring transparency, accountability and predictability to the commission. The bill, among other things, would require the agency to publish the text of any rule within 24 hours of a vote and to post on its website a description of orders made at the bureau level. NAB praised the vote, saying a more efficient and transparent FCC is vital to helping radio and television fulfill their mission of serving local communities.

PANDORA STATION: The Media Bureau approved Pandora’s purchase of KXMZ(FM), Box Elder, S.D., for \$600,000 from Connoisseur Media. The approval was expected after the commission recently waived its 25 percent foreign media

ownership benchmark for Pandora with conditions. In 2013, Pandora announced it intended to buy the station to become a broadcast owner in order to reduce its streaming royalty rates. ASCAP and Pandora are involved in litigation over performance royalties; ASCAP objected to the station purchase. The bureau said ASCAP doesn’t fit into the traditional definition of an aggrieved broadcaster that can fight a transaction, since it’s not a station owner, a regular listener or a listener within the station’s contour. Pandora has been operating KXMZ under a local marketing agreement; the FCC’s action means Pandora and Connoisseur can finalize the deal, which was expected to close in June.

FIRST INFORMERS: Oregon Gov. Kate Brown signed into law a bill that allows designated broadcast personnel to enter areas during an emergency to maintain “essential broadcast equipment.” The Oregon Association of Broadcasters, in collaboration with the Oregon Office of Emergency Management, is tasked with developing a procedure to credential such “First

Informers.” Under HB 2210, “essential broadcast equipment” includes repairing or resupplying transmitters, generators or other essential gear at the station or transmitter site. First Informers can travel on roads in designated emergency areas and have access to fuel, water, food, supplies or equipment. Several other states have similar programs.

PROGRAMMATIC: Marketron conducted its first real-time programmatic radio spot buy. The action came a year after Marketron partnered with Jelli’s programmatic radio advertising platform. Hubbard Broadcasting’s KSTP(FM), Minneapolis-St. Paul, Minn., and Rich Broadcasting’s KSKI(FM), Sun Valley, Idaho, published inventory to Marketron’s Mediascape Marketplace sell-side platform. Starwood’s Aloft hotel group, using a demand-side platform, bought the inventory from KSTP; Wood River Valley Insurance bought the inventory from KSKI. We’ve reported that advertisers and agencies are pushing radio to adopt programmatic spot buys; they consider the process easier than radio’s manual process.

HIGH CAPACITY EVENT STUDIO TRANSMITTER LINKS



outdoor unit



TAKE ADVANTAGE OF WIRELESS HIGH PAYLOAD STL/TSL CAPACITY

Moseley EVENT STL/TSL systems provide up to 155 Mbps combined IP, T1/E1 payloads. Multi-station clusters can convey multiple linear uncompressed audio pairs for a truly cost-effective STL/TSL link. Connect your existing T1/IP audio hardware directly into the EVENT system, or use Moseley Rincon for your audio payloads. An optional DVB-ASI module is available for full duplex video.

EVENT systems are fully bi-directional including a Software Defined Indoor Unit (SDIDU) and Outdoor Unit (ODU), eliminating the need for costly waveguide hardware. The ODU is available in the license free 5.8 GHz band, or licensed 11, 18, or 23 GHz bands. Appropriate external antennas are selected based on path length.



indoor unit

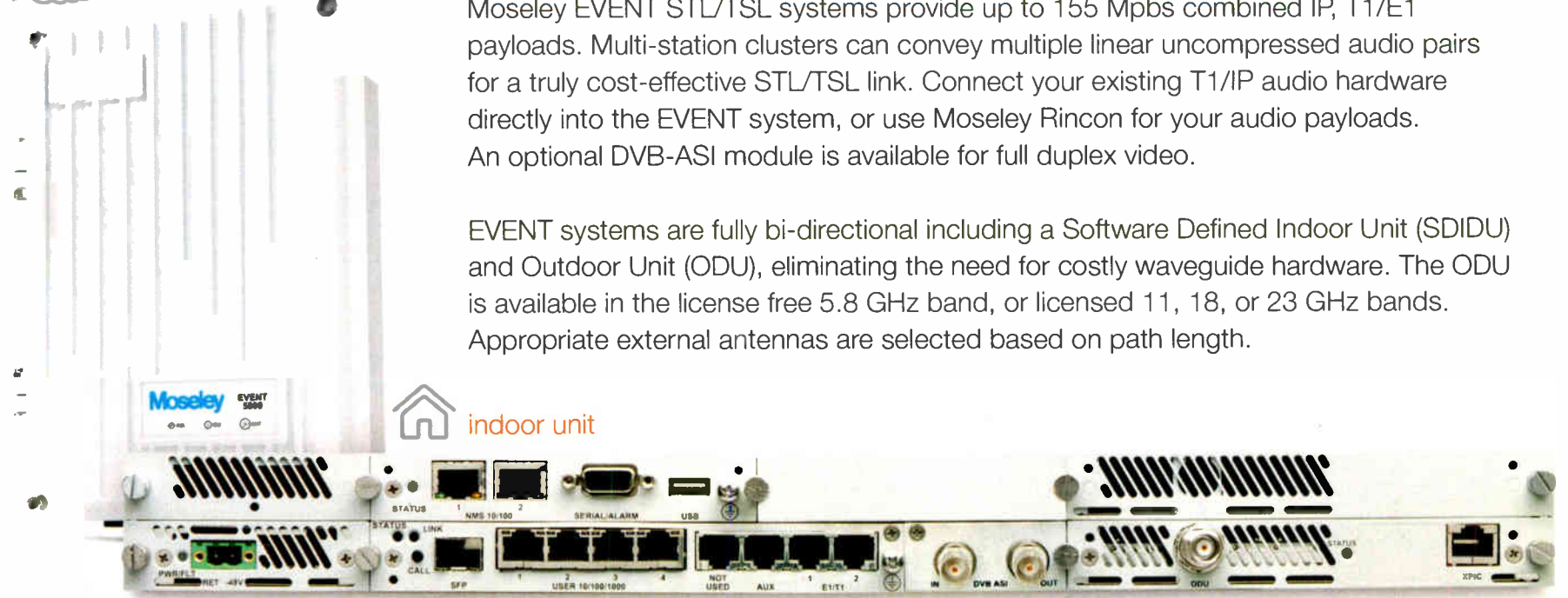

INTELLIGENT SYSTEM DESIGN



Spectrum-scalable digital radios with user-selectable data rates enable broadcasters to have greater flexibility in STL planning and future growth. The integrated T1/E1 and Ethernet interfaces allow for a combination of T1/E1 and IP packet data.



IP APPLIANCES AND APPLICATIONS

Offer IP transmitter control, surveillance security, and site monitoring to reduce downtime, and protect valuable station assets while saving travel time to the site.



REMOTE MIRRORED SERVERS

From the transmitter site, offers backup of business records and programming content to get you back on the air quickly in the event of a studio outage.



EMAIL AND INTERNET ACCESS FROM THE TRANSMITTER SITE

Saves engineers time accessing manuals or technical support from manufacturers during maintenance sessions.



SIMPLE NETWORK MANAGEMENT PROTOCOL (SNMP)

Full SNMP package with GUI provides easy monitoring and configuration changes.

Contact The Moseley Sales Team to Custom Configure Your EVENT STL/TSL Today!

moseleysb.com

Spread That Paperwork Around

Multi-rack documentation simplifies troubleshooting

WORKBENCH

by John Bisset

Read more Workbench articles online at radioworld.com

Shaun Sandoval is market chief for the new Cumulus San Francisco cluster. He was responsible — along with associates like Senior Vice President of Engineering and IT Gary Kline, Vice President Engineering Martin Stabbert and Project Leader Michael Gay — for

new radio studios built in downtown San Fran.

Touring the facility, one can't help but notice the documentation, prepared by Michael Gay. In addition to providing Visio-brand drawings of all the rack equipment, he collated drawings by rack and placed them on the top of each rack with a magnetic clip, seen in Fig 1. The rear of each rack has a duplicate set of drawings and relevant IP addresses, as shown in Fig. 2.

Documentation of equipment and wiring is important, but especially when you have multiple studios. The engineers placed an overall documentation package in the rack room, but by splitting the docs up and assigning bite-size drawings to each rack, they've made service and assessment easier.

Frunk and Dave Hertel, engineers with Newman-Kees RF Measurements, recently built a low-power FM station for a friend who has owned several full-power stations and sold them. The friend couldn't get radio out of his blood, hence the LPFM buildout.

To make the LPFM official, he decided he needed a flashing light atop the 30-foot tower at his house. Frank used an LM-555 timer to drive four super bright LEDs. The total current draw is about 90 mA, so a wall-wart AC to DC transformer will power the circuit. There's nothing fancy about the schematic, see Fig. 3. It can be easily mounted inside an old tower side lamp fixture, to add realism, seen in Fig. 4.

Fig. 5 shows the chrome LED-mounting pipe, a scrap piece of sink drainpipe. The LEDs are glued into holes drilled in the pipe. To mount the pipe, Frank cut two slots about a half-inch apart. Bend the flanges, formed by these slots, 90 degrees. That forms mount-

ing flanges that can be affixed to the side-light socket. The tower side-light fixture is small enough that it can be mounted on a block of wood and used as an "engineer out of office" desk flasher. The circuit can also be pressed into service to signal an EAS alert, hotline ringing or after-hours doorbell in the studio.

Keep in mind that this is a novelty circuit and should not be used as a Federal Aviation Administration-approved tower light flasher.

(continued on page 14)



Fig. 1: Documentation drawings are placed above each rack.

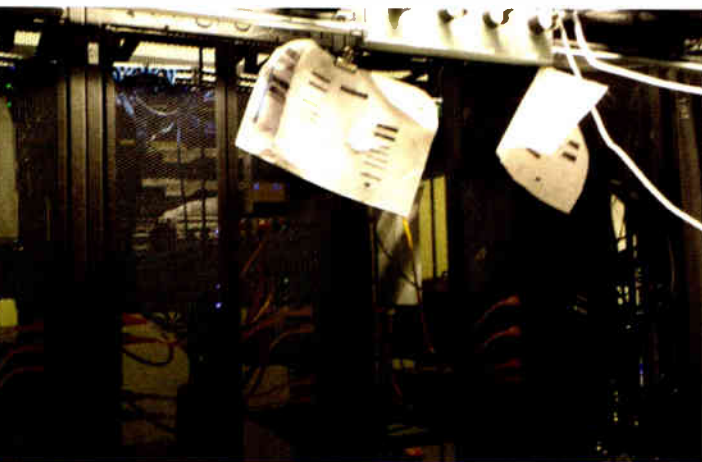

Fig. 2: Duplicate docs are mounted at the rear.

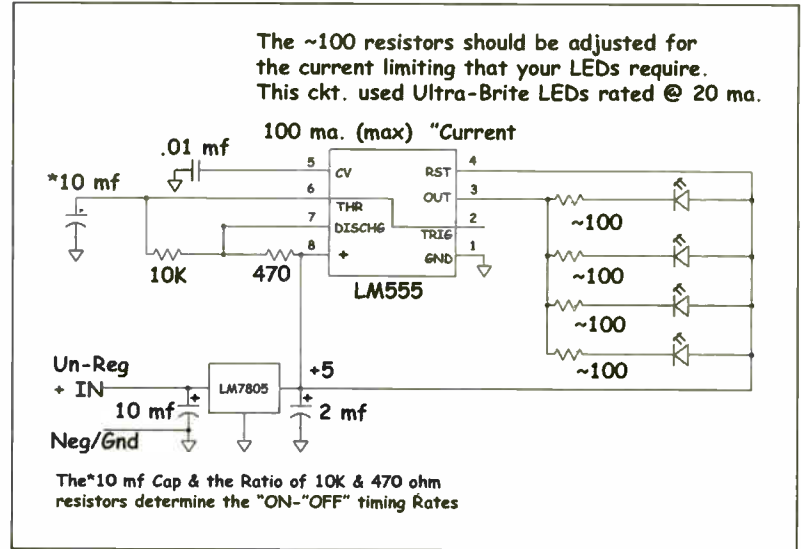

Fig. 3: The flasher circuit schematic is built around the LM555 timer.



Fig. 4: Mount the flasher in an old tower side-lamp fixture.



Fig. 5: The LEDs are mounted to a piece of chrome sink drainpipe.

NEW

Monitor Like a Pro

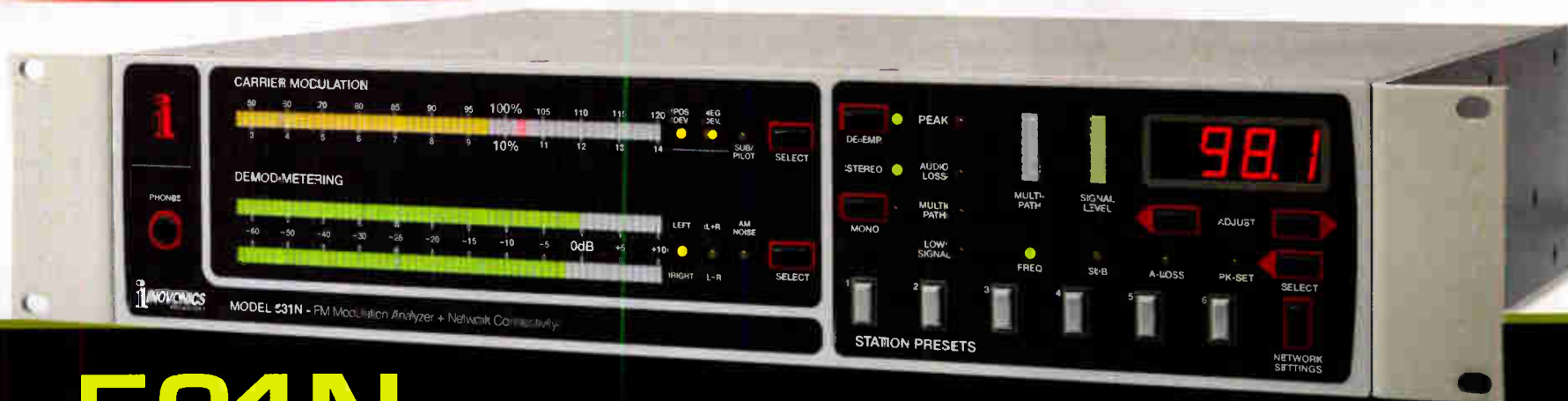

531N

FM MODULATION ANALYZER WITH NETWORK INTERFACE

Features

- Essential FM Signal Monitoring
- Total RF signal performance monitoring —Direct & Off-Air
- Tuning Range: 76MHz - 108.1MHz in 100kHz increments
- Dynamic Web Interface displays RDS data, baseband FFT, audio XY, and Peak Density readouts
- Remote control and monitoring via Web
- Email/SMS error notifications and SNMP



Remote Web Interface

See it for yourself at our 531N product page.



Rear Panel



sales@inovonicsbroadcast.com
phone: 831-458-0552

AAPB Digitizes 60 Years of Public Broadcasting

Organization's mission is to preserve and organize AV history

ARCHIVING

BY KEN DEUTSCH

"Our nation wants more than just material wealth....We in America have an appetite for excellence too. While we work every day to produce new goods and to create new wealth, we want most of all to enrich man's spirit."

With those words, President Lyndon Johnson signed the Public Broadcasting Act on Nov. 7, 1967, ensuring a flow of programming that continues to this day. With some funding from the government in place and donations filling in the bulk of their budgets, local public stations began creating.

Bigger organizations like National Public Radio and the Public Broadcasting Service found deeper private pockets to fund innovative programming that could not be produced on the local level. The original concept of the Public Broadcasting Act was to encourage these new broadcasters to fill a niche that commercial mass-appeal media could not, and that is what happened.

The American Archive of Public Broadcasting is a nonprofit collaboration among the Library of Congress, Boston's WGBH Educational Foundation and about 120 public radio and TV stations. AAPB's goal is to search the shelves of broadcasters and private collectors for public radio and TV programs of significance from the past, and with several grants in hand, digitize these pieces of American history to make them available to scholars and other interested parties. In this manner, these valuable performances, newscasts, interviews and documentaries can be preserved for future generations.

American Archive OF PUBLIC BROADCASTING



Karen Cariani



Casey Davis



Alan Gevinson

To learn more, Radio World spoke with Karen Cariani, director of AAPB and the WGBH media library; Casey Davis, project manager of AAPB at WGBH; and Alan Gevinson from the Library of Congress, who serves as that organization's project director for AAPB.

Radio World: What was the genesis of AAPB?

Gevinson: In 2007, public broadcasting organizations convinced Congress to allow some funds that had been allocated for the digital conversion of stations to be used to digitally preserve materials sitting unused on shelves in stations representing hundreds of communities across the nation. Congress agreed that this

archive of material is a valuable asset to the public and to historians.

Cariani: The Corporation for Public Broadcasting funded 120 stations to participate in a content inventory project managed by WGBH. Stations applied for funds to conduct this work themselves or to hire approved teams to do it. Part of the issue with recorded media compared to books is that with the former, you can't always tell what the content is just by looking at it. Stations found they had saved all kinds of videotape formats over the years including 2-inch, 1-inch, 3/4-inch, .5-inch and helical scan. Audio was found on 1/4-inch tapes and DATs. We had to play a lot of it to figure out what it is, and there may be only one playback possible with some of these tapes.

Davis: Part of the inventory process also involved looking at reels of tape and writing information about each item down, often in a PBCore-compliant CSV or Filemaker template. Information included a unique identifier, title, format, duration, description, generation, date, condition notes, etc. We found a station in Utah that had material from 1955, and here at WGBH, we uncovered an audio disk from 1949, both of which predate the current structure of public broadcasting established in 1967.

RW: What are your standards for the digitized material, and where will you store it?

Davis: For audio we recommend a 96/24 uncompressed linear PCM in a Broadcast Wave Format (.wav). We will make our detailed technical requirements available to people who are interested. Up to this point, we have worked with a single vendor on the digitization of AAPB content, and as we continue to grow the collection, we imagine that we will receive some items that have already been digitized or were born as digital files.

Gevinson: The preservation files will reside in the Library of Congress Packard Campus Digital Archive at the National Audio Visual Conservation Center in Culpepper, Va. Everything will be migrated at least once every five years in perpetuity, and proxy files will be kept at the Library of Congress and at WGBH.

The AAPB project team, in collaboration with several other parties, is implementing a strategy to make as much of the collection available in our Online Reading Room (launching in October 2015) as possible. The Online Reading Room will be virtual, providing viewing/listening access to potentially thousands of items in the collection and is restricted to research, educational and informational purposes. It will be presented under fair use and other legal doctrines. The entire AAPB collection is available for research on location at WGBH and at the Library of Congress. We want to collaborate with educators and scholars to see how we can best meet their needs, and how to get this material used as broadly as possible.

RW: Sounds like a big project! How are you coming with it?

Cariani: The amount we have digitized so far is about 40,000 hours, or 68,000 items, just a drop in the bucket compared to what is available. We want

(continued on page 19)

WORKBENCH

(continued from page 12)

Mark Voris, technical director for Spirit Catholic Radio, always comes up with a great tip or two. Fig. 6 is no exception.

Some engineering tasks require a third hand; soldering certainly falls into that category. It can be a chore to juggle solder, the iron and the wires or connector. If you've seen my NAB Show or SBE Workbench presentations, you know a spring clipboard can come in handy. The spring clip holds the connector to be soldered and frees your hands to manipulate the solder and iron. But what if you have to solder wires or resistors to a terminal strip in a rack? Fig. 6 provides the answer.

I wonder if soldering iron manufacturer Weller knew the diameter of its soldering irons was the ideal dimension to fit into a standard mic stand?

Desk stands will work too, but the beauty of the floor stand is that the iron can be positioned in the upper portions of an equipment rack.



Fig. 6: Use a floor mic stand to hold a soldering iron inside a rack.

Contribute to Workbench. You'll help your fellow engineers and qualify for SBE recertification credit. Send tips to johnbisset@gmail.com. Fax to (603) 472-4944.

Author John Bisset has spent 45 years in the broadcasting industry and is still learning. He handles West Coast sales for the Telos Alliance. He is SBE Certified and is a past recipient of the SBE's Educator of the Year Award.

The Future of Automation Is

NOW...

SEE FOR YOURSELF
ENCO.COM/ENCO1



ENCO

800 ENCO-SYS

The Intelligent Network News



Beauty is in the eye of the beholder, the ears of your listeners,
the knowledge of your engineers, the voice of your jocks, the
power of your network, and the strength of your ratings.

get some beauty
Get LX-24

 **Wheatstone**
BROADCAST AUDIO PERFECTIONISTS®

World Radio History



Which Switch for AoIP?

IP audio networks are very different from standard enterprise or office networks in almost every way, but none more spectacular than the nature and volume of traffic.

For this reason, the Ethernet switches used in an IP audio network like WheatNet-IP need to have a high-capacity fabric, which is the actual mechanism that

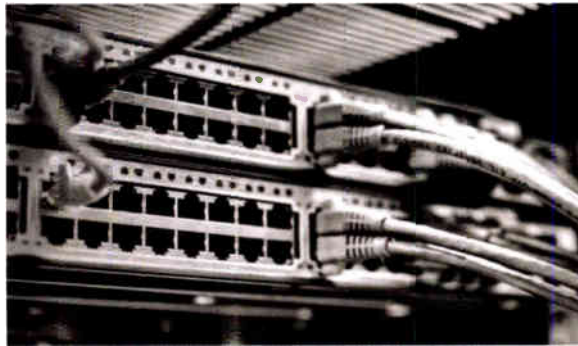

allows the switch to pass data among its ports. There are different ways that switches handle traffic – store and forward, cut-through, fragment-free, adaptive switching – but regardless of fabric used, it needs to be of sufficient capacity to handle full bandwidth traffic without blocking. Also imperative: the switch needs to be a managed switch and it has to be able to snoop IGMP packets and switch them appropriately. Otherwise, multicast traffic is going to flood everywhere. For other tips and an in-depth look at switches for IP audio networking, go to:

For the entire story... INN23.wheatstone.com



IP Consoles 101

Sometimes, even we forget that our IP networked consoles don't actually have live audio in the board itself. (That's why we call them control surfaces – so we'll remember that they control the audio, not store it!)



Shown is web radio OWWR's number-one studio with IP-12 control surface, M-2 dual mic processor, and just the right amount of WheatNet-IP audio networking. Check out those baby-proof covers on the Tripp-Lite power module!

We don't envy guys like Joseph Manfredi, who has to explain

IP control surfaces to a group of new students every year as a faculty member in the American Studies/Media & Communications department and station manager for OWWR web radio at SUNY College in Old Westbury, New York. "I'll never convince them that there's nothing under that fader," says Joe, referring to the station's new IP-12 control surface.

Joe has four studios that he teaches out of and streams 25 live shows from weekly, the most up-to-date one being his "Studio A," with the IP-12, M-2 dual-channel mic processor and WheatNet-IP audio network that he and his chief engineer installed last year. The IP-12 is an ideal entry into AoIP for small studios, providing a self-contained digital audio board with WheatNet-IP audio network BLADE engine for flexible access to sources and destinations. "My 'yesterday' studios look and function okay, but this is the one that gets it done," says Joe.

For the entire story... INN23.wheatstone.com



Analog, Yet Digital In All The Right Places

Audioarts AIR-5 gives you smart bells and intelligent whistles.

This past NAB, Wheatstone and Audioarts introduced a number of new mixing consoles, processors, network devices and more. The brand new Audioarts AIR-5 brings together USB and optional Bluetooth, along with a built-in dedicated phone channel, to make a powerful compact board. Check it out - and ALL the new gear introduced at NAB...

Just click here! INN23.wheatstone.com



What to Expect When You're Expecting an LPFM

Permits and construction considerations are paramount

REGULATION

BY PETER GUTMANN

There's no doubt about it: Low-power FM stations are becoming a significant part of the radio landscape.

According to FCC statistics, by the end of March, 1,025 LPFM stations were licensed, 145 facility modifications had been issued, 1,406 construction permits were in effect for as-yet unbuilt stations and 423 applications for new stations remained pending. It seems apt to welcome LPFM into the media mix.

This is the first of a series of four articles in which we'll take a look at LPFM procedures, requirements and prospects. In future installments, we'll consider operational issues and long-term opportunities.

I'd love to be able to start with an outline of how to apply for a new LPFM station, but that would be cruel. LPFM applications are only accepted during FCC filing windows. The last FCC LPFM filing window closed in November 2013. No one can predict when, or even *if*, the next one might open.

So in this first segment, let's discuss some of the considerations regarding the construction of an LPFM station, once the FCC issues the initial construction permit.

BASIC PARAMETERS

Needless to say, the station needs to be built with the basic parameters authorized in the FCC construction permit — channel, location, height, power. But what if changes are needed? Fortunately, the FCC affords some limited leeway. For example, the antenna may be mounted up to two meters higher or four meters lower at the same geographic coordinates without a change in the construction permit.

Most other technical changes require a modified construction permit. Any technical change must fall within the FCC's definition of a "minor change." An LPFM station minor change includes moves within 5.6 km of the specified site and to adjacent and I.F. chan-

nels. And of course, you need to observe the required distance separations from all authorized or pending FM facilities, including FM translators.

But don't wait too long. LPFM construction permits

Thus the commission decided to afford LPFM permittees one 18-month extension to the original construction permit time period to construct upon a showing of good cause, which generally requires circumstances beyond an applicant's reasonable control. At the same time, the FCC cautioned that any addi-



LPFM construction permits are valid for only 18 months — half the time period of full-power services.

are valid for only 18 months — half the construction time period of full-power services.

Are extensions possible? In shortening the LPTV construction period in 2007, the commission sought to balance its concern over sitting on valuable spectrum against its recognition that inexperienced LPFM permittees could face legitimate delays, especially given the noncommercial, community-based nature of the service.

tional extensions (that is, beyond a total of 36 months to construct) would be subject to the same extremely limited circumstances as full-power permits — delays caused by natural disasters, certain legal proceedings or international coordination issues.

What if some of the original board members have lost interest, moved away or perhaps even died? That's OK, but a change in more than 50 percent of the origi-

Introducing the new
"MINI"
Low Profile Mic Boom!

Studio Items Inc.
www.studioitems.com
 800-779-7575

nal members requires FCC consent.

Keep in mind that the basis for any comparative “points” used to choose a winner among mutually exclusive applicants must be preserved. Among these is the point awarded for being local, which requires that either a headquarters office be located, or 75 percent of board members reside, within 20 miles of the transmitter site (10 miles within the top 50 urban markets).

So, unless a local headquarters was claimed as the basis for a localism credit, replacement board members need to qualify as “local.” And, since to qualify for an LPFM, no member can have any attributable interest in another broadcast station, it is essential that any new members comply with that restriction.

What if the applicant itself has changed plans — can an LPFM permit be sold or even given to another party?

AAPB

(continued from page 14)

to grow this collection as we serve as stewards for public broadcasting. Civilization’s cultural and social heritage was documented on paper and in photographs for many

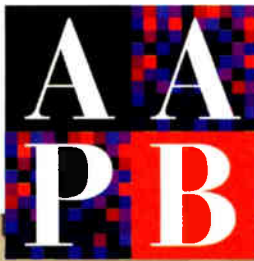

RW: Is this effort related to the Library of Congress National Recording



Alan Gevinson and Karen Cariani

years. Unfortunately, video and audio are prone to deterioration much more quickly than those media, so think of the history that will be lost if we can’t migrate this material.

RW: From where do you get your funding?

Cariani: AAPB received \$1 million grant from CPB, money designated to cover two years of management of the digitization process and to launch a website where some of the archived

That one’s easy to answer: No.

LPFM stations are not required to have main studios. However, a comparative point is awarded to applicants

Keep in mind that the basis for any comparative “points” used to choose a winner among mutually exclusive applicants must be preserved.

that agree to have one. If you certified in the construction permit application an intention to have a main studio, then it must be reachable by phone, staffed at least 20 hours per week between 7 a.m. and 10 p.m., and located within 20 miles of the transmitter site (10 miles

material will be available. One grant was also received from the Council on Library Information Resources and another from The Institute of Museum and Library Services, but AAPB still needs more funds to continue the work.

RW: Is this effort related to the Library of Congress National Recording

in the top 50 urban markets). The construction permit application required that the main studio address be specified. Should the original studio location

become undesirable or unavailable, it may be possible to move to another location that meets the distance qualification, with assent of the FCC.

Your LPFM programming can come from any legal source (that is, any source for which you have the rights). However, if you claimed the comparative point given to those who pledge to originate at least eight hours of programming per day, then you need to abide by that.

Once construction is completed, LPFM stations may begin equipment tests upon notification to the FCC secretary. The purpose of equipment tests is to assure compliance with the terms of the construction permit and applicable FCC rules and engineering practices,

and to make any adjustments that may be needed. Once proper operation is verified, you can begin program tests, which essentially permit regular operation and programming. However, you must file a license application within 10 days. The license application requires a certification that the facility was constructed as authorized in the underlying construction permit, plus disclosure of any permitted variances. In addition, compliance must be demonstrated with any special operating conditions listed in the construction permit.

Once operation begins, the possibility arises of interference complaints. An LPFM station is required to protect full-power FMs within their communities of license and their 70 dBu contours. This protection applies to applications filed at any time by both commercial and noncommercial full-power stations. Special rules, well beyond the scope of this article, apply to third-adjacent channel interference and in some instances mandate that announcements be aired to invite listeners with reception difficulties to contact the LPFM station.

Next time we’ll look at some operational issues, so stay tuned!

Peter Gutmann is attorney with Womble Carlyle Sandridge & Rice LLP. He can be reached at pgutmann@wcsr.com.

DISTRIBUTION, ANALOG & DIGITAL

NEW DIGITAL PRODUCTS FOR 2015



HOW TO GET FROM HERE TO THERE, THERE, THERE, & YEP, EVEN THERE...

The AES Digital DA 2X4 sends AES digital audio to four “theres.”
Feed in AES or S/PDIF, and get four AES zero-delay “clones.”
Bit-accurate, no latency, no problem!
In stock at Henry Engineering dealers.

DIGITAL SOLUTIONS. ANALOG SOLUTIONS. FUNCTIONAL. RELIABLE. AFFORDABLE.



Visit www.henryeng.com for all of Henry’s solutions!
NEW Phone: 562.493.3589 • email: Info@henryeng.com



Your Data Is, Well, *Your* Data

Take advantage of cloud storage, but maintain your privacy in the Internet zoo

RADIO IT MANAGEMENT

BY TODD DIXON

Tim Berners-Lee, credited as the inventor of the World Wide Web, is quoted as saying “Data is a precious thing and will last longer than the systems themselves.”

Certainly, there are no shortage of backup solutions on the market that

Then when we transitioned to the iPad platform for our writers and sales, I set up a server that provided webDAV (Web folders) for their data backups.

With the advent of “cloud” services, a number of our people have begun using outside sources to backup their data, namely Dropbox, iCloud and Google Drive. Obviously, the chief advantage is that the data is available at their fingertips with whatever device they choose to use. But another pro is that all of the services are intuitive and easy to use.

For the casual user, OwnCloud has similar attributes to each of the services named previously. The ability to upload files, place them in organized folders and to share those files (or folders) by providing a link to them are some of its primary features. Like Dropbox and others of that ilk, OwnCloud provides a number of their own as well as third-party apps that extend its capabilities beyond its basic use. Some of the higher-rated extensions are a Mozilla Firefox data sync, task synchronizer, a music server and client player and an OwnCloud Chat app. It is accessible via an app (99 cents in all mobile app stores) for mobile devices or by Web browser for computer.

DIY OWN CLOUD

Installation of OwnCloud is pretty simple. In the most basic sense, once you create a webserver, you copy the OwnCloud folder into the webserver’s publically available folders, and *voilà*, Owncloud!

With that last sentence, I may have dashed your visions of your own installation of Owncloud. “What do you mean ‘create a webserver’? You have vastly overestimated my abilities!” Perk up and stay with me; you’ll have an opportunity to log into our OwnCloud instance and download some step by step instructions for installing Owncloud on a computer running Windows, Linux or even a Raspberry Pi (wow — at \$35, that’s a future article)! You won’t be hosting Amazon or Google on your webserver, so it won’t require the highest specification computer to run it. In fact, the Pentium 4 you are about to replace will be the perfect computer to experiment with and host your own Owncloud site on your local network and to the world.

If you’ll go to <https://tinyurl.com/myuvrfg>, the link will direct you to our Owncloud instance. You can log in with the username “rwgust” and the password “owncloud” and download the Owncloud installation document to your computer and take your first step toward getting back control of your data. The screenshots included here illustrate the simplicity of the user interface.

Todd Dixon is an assistant engineer at Crawford Broadcasting’s Birmingham facility and a regular RW contributor.

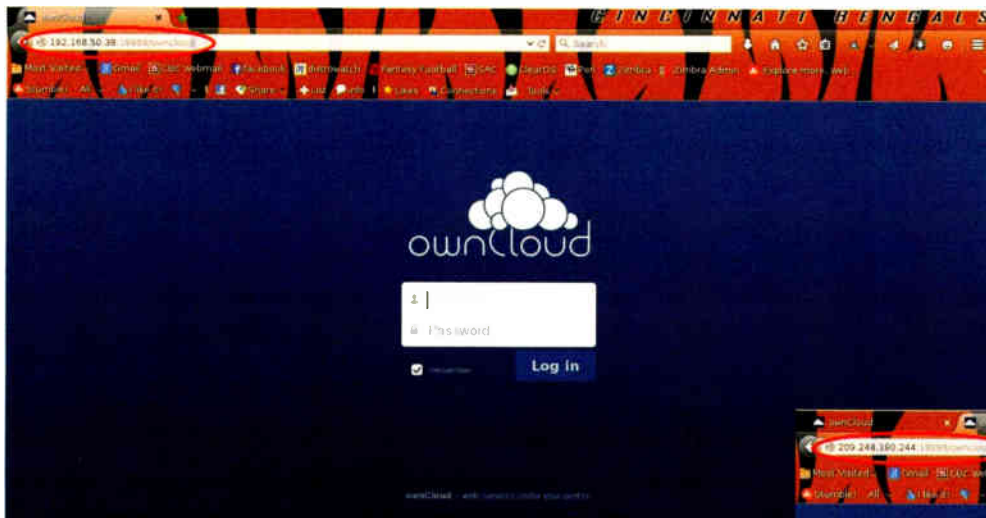

Users can log into an Owncloud instance on their local network.

Big targets on the Internet attract hackers who mean to do those companies harm; and there sits our data.

provide redundancy, whether it is network attached storage, external USB-type hard drives, the standard file server or, more recently, Internet-based cloud solutions.

In fact, I’ve written in Radio World about such solutions in my own efforts to provide my station with some basic data backup. FreeNAS was a BSD server solution we used for a period of time.

The con is that our company’s employee-created data was becoming an exhibit in the Internet zoo. Big targets on the Internet attract hackers who mean to do those companies harm; and there sits our data.

OWNCLOUD

To protect against that possibility, I started searching for a solution that would rival what those companies provide and yet keep our data in a harder-to-find target under our watchful eyes — more specifically, in a server located about 10 feet from me and on our network. OwnCloud is where my search ended.



Users can also log into the “rwgust” account from anywhere on the Internet.



The “rwgust” account with its files and folders. From left to right, users can manage available extensions, upload and share files and folders, and tweak their account settings.



Follow That Space Station!

And variety is probably good for your smart TV's health, too



What'sNext is Radio World's watch on everything new in audio content distribution. Among the interesting recent items that have come across our desk:

RADIOISS

Ever wonder which radio stations the astronauts on the International Space Station might tune to as they circle the globe every 90 minutes?

The streaming audio site [radioISS](http://www.radioiss.com) (www.radioiss.com) answers this question in real time. In addition to featuring a window with the ISS live HD video feed — when it's up — radioISS offers a map showing the ISS's current location

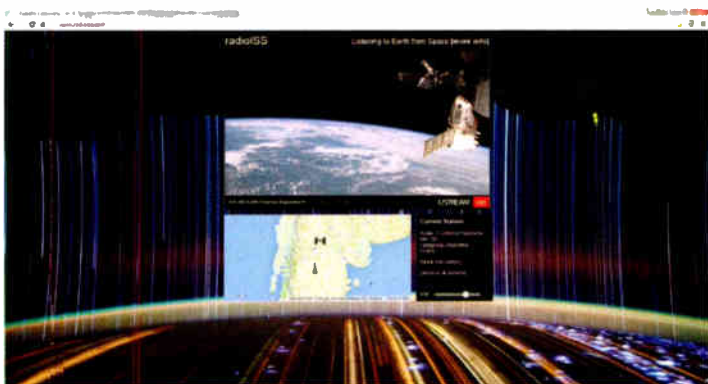

radioISS

relative to the ground, and streams audio from radio stations located in that area.

This website was created as an experiment by Greg Murphy, "ably assisted by his brother Ken," says the More Info page at www.radioiss.com. As the ISS moves, the Earth map and available stations change.

CHROMECAST BOOSTS RADIO APPS

Google's \$35 Chromecast dongle is being pitched to people who want to watch Netflix and other online video



Chromecast

streamers on their smart TVs. However, this device can also run radio apps — and Google is now offering lots of them.

When Chromecast launched in 2012, it only had two radio apps. Now there are more than 90 available on the platform. They include TuneIn Radio (the big database of broadcast/Internet-only stations and podcasts), 8tracks (person-curated playlists and stations), NPR One, last.soma (32 "different" eclectic, ad-free music stations), and Songza (another person-curated app). Chromecast also supports podcast apps such as Beyondpod and Pocket Casts; and streaming audio apps such as Pandora, Rdio and Google Play Music.

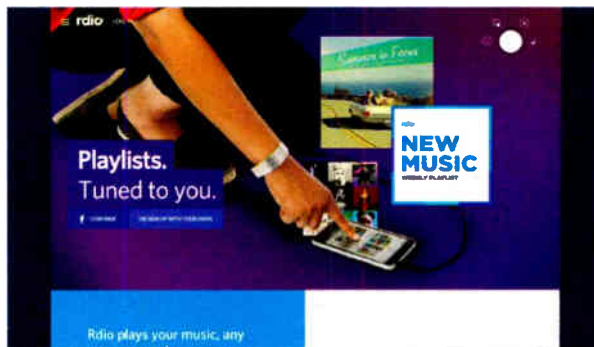

RDIO

RDIO

Can you hear me now? If it's the streaming audio service Rdio.com that you want to listen to on your mobile device — and if you're in the Asia-Pacific, the Caribbean or Central America — the answer may now be yes.

"Through our exclusive partnership with mobile phone network provider Digicel, Rdio will be available in 24 new markets and an additional seven regions," stated Rdio on its blog (<http://blog.rdio.com/ca/news>). "Digicel will

offer all prepaid data customers 30 minutes of free Rdio Internet radio listening per day on their mobile phones without accruing data usage charges." Digicel will also help Rdio "infuse local influence" into curated playlists aimed at these regions.

SIMPLE RADIO FOR ANDROID

What'sNext looked at the streaming media site [Streema](http://streema.com) (<http://streema.com>) a couple columns ago, and discovered that it was an extremely easy-to-use way to access both radio and TV station feeds. Well, clearly the world reads What'sNext — at least we like to think so — because the iOS app that Streema released in October 2014 (and which

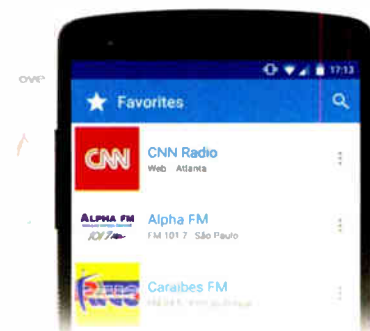

Streema

we mentioned) has achieved more than 500,000 installs from the Apple Store.

Streema is following up on its iOS success by launching an Android app. Called Simple Radio for Android and available at Google Play (<http://streema.com/mobile>), this Streema app can access about 25,000 radio stations from around the world, and covering most genres of music and talk. Streema says its online service reaches more than 5 million users each month.

Among iOS Streema app users, "We have an average of 4.5 out of 5 stars, which we attribute to our simple design and focus on minimizing friction within the user experience," said Richard Monte, CEO of Streema. "We have purposefully chosen to stay away from extraneous features by keeping it simple and giving users exactly what they want — access to their radio stations as fast and reliably as possible."

Don't mention it, Streema: we're happy to help. (Still, it wouldn't kill you to send flowers.)

James Careless reports on the industry for Radio World from Ottawa, Ontario.

ACCURATE 24:7

Trust the name broadcasters have counted on for precision master clocks and timing-related products for over 40 years—ESE. Our products accurately synchronize broadcast operations using a choice of GPS, NTP, Modem, Crystal or line frequency for affordable, reliable, perfect time—all the time.

Visit www.es-web.com to witness world-class timing systems designed for easy installation, set-up and operation.

142 Sierra Street,
El Segundo, CA 90245
(310) 322-2136

www.es-web.com

My Love Affair With an Ampex Recorder

I desperately wanted that recorder; it was the most beautiful thing that I had ever seen

FIRSTPERSON

BY READ BURGAN

A recent photo in the Workbench column (Feb. 1 issue) showing an Ampex AG600 tape recorder brought back memories. *Lots* of memories.

I saw my first Ampex 600 in the mid-1950s; it was love at first sight. It was lying on our dining room table. My father had brought it home from radio station WHDF(AM), where he was chief engineer and majority stockholder.

Instead, I had to settle for a 1947 Brush Soundmirror BK-401 tape recorder that my dad convinced the radio station to sell me for \$15. That was the best \$15 I ever spent, but that's another story.

In the mid-'60s my college held a special assembly. A man showed travel slides on multiple screens using Kodak Carousel projectors. I don't remember anything about what was on the screens, but I'll never forget that *sound!* Wonderful, glorious full-fidelity stereo sound.

It came from two Ampex 620 speaker/amplifiers, each mounted in their own brown Samsonite luggage cases

had a rack-mounted Ampex 402 in my closet as well.

One day I was asked to let the college use the recorder for chapel. That weekend the Chicago Symphony performed in the several thousand seat chapel. When they left, so did my Ampex 601.

I pleaded with the powers that be to pay to replace it but was told that their insurance didn't cover student property. That was the last time that I saw my

KNBC announcer Jack Wagner records a news feature from the San Francisco waterfront in the mid-1950s. The recorder is the famous Ampex 601 professional suitcase portable, an industry workhorse for several decades.

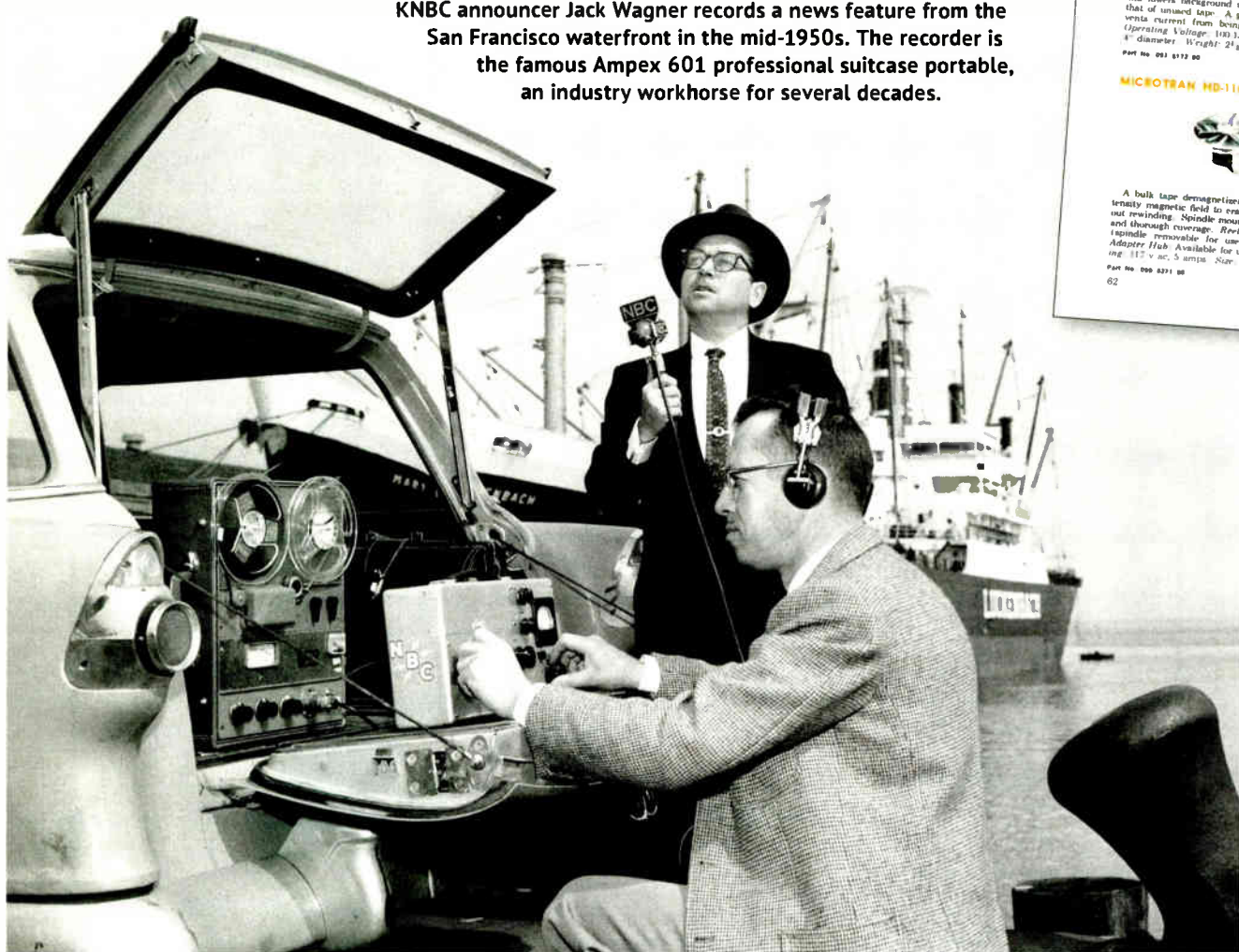

Photo via John Schneider. Courtesy Mike Adams from the Jack Russell Wagner photo archive

It wasn't the first tape recorder to sit on our dining room table. Before that there were a Magnecord PT6-A and an Ampex 400. Man! Was that Ampex 400 ever big.

Over the years, our dining room table held more broadcast equipment than food.

At about 10 years of age, I desperately wanted that recorder. It was the most beautiful thing that I had ever seen.

that matched the Ampex 601-2 stereo tape recorder that provided the sound track. More than ever I knew that I *had* to have my own Ampex 600 series tape recorder.

In the late '60s I was in graduate school and now I owned my very own treasured Ampex 601 half-track tape recorder, for which I had traded this and the other thing. (I don't remember what. Maybe my mother?) By then I

beloved 601.

Fast-forward to the 1970s. I was director of a 100,000-watt stereo FM facility at a state-owned university. One day I walked into the university's public relations department and there were *two* Ampex AG-600-2 tape recorders. Stereo/solid state *and* two-speed!

A few years earlier we'd spent a wad of money upgrading our facility with HEW funds and purchased an Ampex

440G and a several Crown 800 tape recorders. But I could easily envision what we could do with *two* portable Ampex AG-600-2 stereo tape recorders, so I set out to convince Larry, the director of public relations, that his staff

RECORDING

REEVES ST-466 BULK SPLICING TAPE
Reeves splicing tape for use with Collins Automatic Programming equipment recording tape. Mylar 1 1/2" wide and supplied in 66' roll.
Part No. 600 0190 00 \$1.25

ROBINS TS4-DLX SPLICER CUTTER
Used for magnetic recording tape, this unit cuts two rounded indentations in the tape splicing giving the tape a "fish-tail" shape and leaving the edges from its base and mounted directly on any tape and tape level.
Part No. 097 2050 00 \$8.50

MAGNERASER 2COC TAPE ERASER
A compact and convenient bulk tape eraser that removes recorded signals from tape up to 30 mm in size that of unused tape. A push-button safety switch prevents current from being applied when not in use. 8" diameter. Weight: 2 1/2 lbs.
Part No. 001 0112 00 \$10.00

MICROTRAN HD-11M TAPE ERASER
A bulk tape demagnetizer that develops a high intensity magnetic field to erase signals and noise without rewinding. Spindle mounting of reel permits rapid and thorough coverage. Reel Size Range: 2" to 10 1/2" (spindle removable for use with other size reels). Adapter Hub Available for use with 10 1/2" reels. Rating: 117 v. ac, 5 amps. Size: 5" W, 3" H, 8" D.
Part No. 000 0231 00 \$10.00

AMPEX 601 SERIES RECORDER
A lightweight and convenient portable recorder that is ideal in a variety of broadcast situations. The Ampex 601 has synchronous motor drive with a timing accuracy within 2.6 seconds during 30 minutes playback. Record and playback amplifiers are separate units.
The 601 Series is available in the following combinations:
Unmounted 7 1/2 ips, full track (Model 601); 7 1/2 ips, full-track (Model 602); 3 1/2 ips, half-track (Model 603); 3 1/2 ips, half-track (Model 604); 3 1/2 ips, full-track (Model 605); 3 1/2 ips, half-track (Model 606); 3 1/2 ips, full-track (Model 607); 3 1/2 ips, half-track (Model 608); 3 1/2 ips, full-track (Model 609); 3 1/2 ips, half-track (Model 610); 3 1/2 ips, full-track (Model 611); 3 1/2 ips, half-track (Model 612); 3 1/2 ips, full-track (Model 613); 3 1/2 ips, half-track (Model 614); 3 1/2 ips, full-track (Model 615); 3 1/2 ips, half-track (Model 616); 3 1/2 ips, full-track (Model 617); 3 1/2 ips, half-track (Model 618); 3 1/2 ips, full-track (Model 619); 3 1/2 ips, half-track (Model 620).
Frequency Response: 1000 to more than 4 db at 15,000 cps, -2 db at 10,000 cps. Signal-to-Noise Ratio: Over 53 db at 10,000 cps. Signal-to-Noise Ratio Output: 60 db output, 1.25 ohm balanced or unbalanced. Power Requirements: 117 v. ac, 50 cps, 50 cps on N 1 D. Weight: Approx. 20 lbs.

Part No. 000 0081 00	(Type 601)	\$590.00
Part No. 000 0082 00	(Type 602)	\$590.00
Part No. 000 0083 00	(Type 603)	\$590.00
Part No. 000 0084 00	(Type 604)	\$590.00
Part No. 000 0085 00	(Type 605)	\$590.00
Part No. 000 0086 00	(Type 606)	\$590.00
Part No. 000 0087 00	(Type 607)	\$590.00
Part No. 000 0088 00	(Type 608)	\$590.00
Part No. 000 0089 00	(Type 609)	\$590.00
Part No. 000 0090 00	(Type 610)	\$590.00
Part No. 000 0091 00	(Type 611)	\$590.00
Part No. 000 0092 00	(Type 612)	\$590.00
Part No. 000 0093 00	(Type 613)	\$590.00
Part No. 000 0094 00	(Type 614)	\$590.00
Part No. 000 0095 00	(Type 615)	\$590.00
Part No. 000 0096 00	(Type 616)	\$590.00
Part No. 000 0097 00	(Type 617)	\$590.00
Part No. 000 0098 00	(Type 618)	\$590.00
Part No. 000 0099 00	(Type 619)	\$590.00
Part No. 000 0100 00	(Type 620)	\$590.00

This image is from a 1962 Collins catalog.

didn't use them that much and when they needed to make audio clips they were welcome to use our facility.

Larry coveted something, too: The radio station! He had long wanted the university to change our reporting structure to make him our boss, thus putting the radio station in his hands. I wanted those tape recorders, but not enough to turn control of the radio station over to him.

In the end, Larry didn't get the radio station, and I didn't get the Ampex AG-600-2s.

Later, I learned that although the AG-600 series were similar in looks to the original version, the insides were dramatically different. In order to adapt the machines to two speeds, the company had to redesign the mechanics. Like its consumer models, the AG-600 series didn't hold up under the wear and tear of professional use. All that glitters isn't gold; all that bears the Ampex name didn't share the famed Ampex reliability. I still miss that Ampex 601. Sigh!

Read Burgan is a freelance writer and former public radio station manager specializing in digital audio restoration (<http://rgbdigitalaudio.com>). His email is rgb@chartermi.net.

Sales Folks, Let's Get Back to Basics

Set expectations and stick with what works in advertising

I love it when radio advertising works. The client is happy. The account executive is happy. The sales manager is happy. The program director is happy. Life is good.

When radio advertising doesn't work, what do we commonly do? Find new clients?

Nope, there is a better way. Let's get back to basics.

Exactly what makes advertising via radio succeed is a fascinating subject that is rarely discussed today, and yet it is central to our success.

DEFINE SUCCESS

While it is necessary to set revenue goals for radio account executives, this should not be the only metric by which success is measured. When money is the only goal, "get it while you can" and "deal with the results later" will dominate the culture.

Inevitably, the time arrives when campaigns fail to produce significant results and then clients declare to account executives that "radio doesn't work, so we're shifting budgets to try something new. Maybe digital or social will perform better."

If you're a manager who is sick of going through this routine, I highly suggest you add two more data points to how you score success for your sales people. Once your reps can view client campaign success and client retention as equal milestones, you'll see behavior patterns change.

Ideally, every advertising campaign starts with your account executive playing detective and asking simple questions to ascertain what a client is attempting to accomplish with each buy.

Begin with the most obvious yet challenging question: How will success be measured? Choices might be:

- Generate 10 percent more foot traffic
- Boost sales 20 percent
- Improve brand recall 15 percent
- Grow market share 10 percent for the month
- Sell 15 new cars
- Grow a database by 50 names
- Get 200 visits to a website, etc.

Next, what market reach and frequency is ideal with this campaign?

And if it's not too sensitive an area, try to find out who is creating the actual commercial, and if it can be altered, when necessary, to change results when airing over a significant period of time.

Finally, ask if other media such as TV, print, digital or social is being run in conjunction with radio.

Experienced account executives should be able to determine from this conversation whether client expectations are reasonable and subsequently provide appropriate advice. But even reps who have been at this intersection many times will need council from a seasoned sales manager — or input from a creative production manager or program director — before coming back to the client with ideas on how to improve a campaign.

TURNING & TOUCH POINTS

Two of the most common success or failure points concern the actual scheduling of reach/frequency and the copy/production of the commercial. Entire treatises have been written regarding these topics; I

suggest some research when you have time.

If you are not familiar with these subjects and desire a one-paragraph crash course, I'll attempt to distill: There is no question that high-velocity, compressed scheduling is more effective. When schedules are run in tandem over several stations — whether in your cluster or not — the odds of generating results are much higher. Even a one-station advertising buy should run more times over fewer days, so listeners hear it frequently in a compressed time period. High frequency matters because it directly affects retention of the information and is much more likely to generate action. Reach is vital because the more people hit repeatedly with the same message increases the quantity of potential customers for the product or

PROMO POWER



Mark Lapidus

service being advertised.

I am huge believer in setting the proper expectations with advertisers going into campaigns, following up during a schedule run and then circling back at the conclusion to discuss results. Each of these touch points enables relationship growth and builds trust. This, in turn, creates a higher customer retention rate.

When you hear the term "traditional media" used pejoratively about radio and television advertising, you can get mad — or just keep smiling as you deliver cost-effective results that, when used properly, can drive a mass audience to real action.

The author is president of Lapidus Media. Contact him at marklapidus@verizon.net.

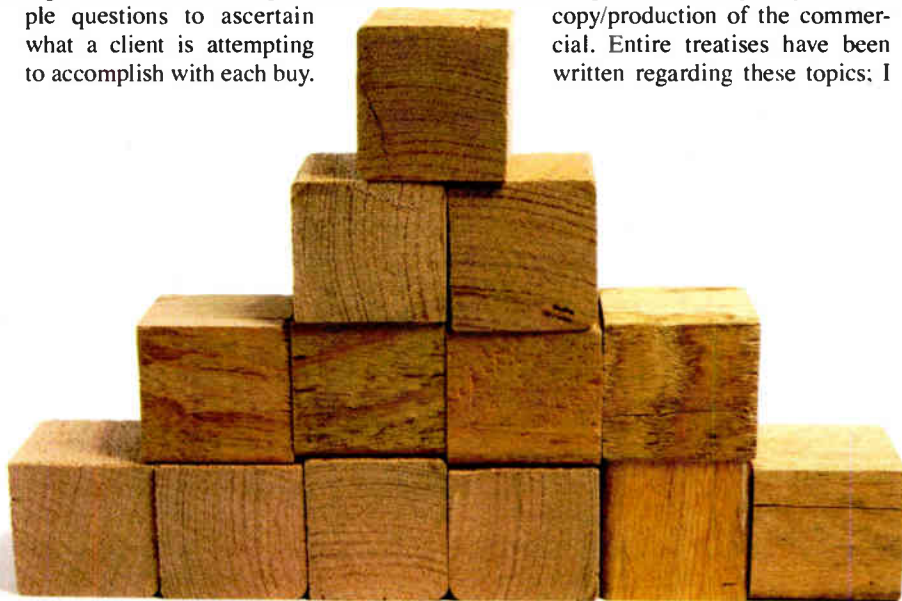

iStockphoto/Westlight

eBooks: Tools for Strategic Technology Decision-Making



Radio World's growing library of eBooks can assist you in maximizing your investment in an array of platforms and tools: licensed transmission, online streaming, mobile apps, multicasting, translators, podcasts, RDS, metadata and much more. The eBooks are a huge hit with readers. They help engineers, GMs, operations managers and other top radio executives — radio's new breed of digital, cross-platform decision-makers — understand this new world and thrive in it.

Visit radioworld.com/ebooks



Find the Road Home for Success

Mark Ramsey on the death and (re)birth of personality radio

PROGRAMMING

BY TOM VERNON

Radio stands at a crossroads; to move forward, it needs to rediscover its roots. So says Mark Ramsey, media strategist and critic of radio-as-a-jukebox formats.

Like many other things, formats have a cyclical nature; Ramsey believes it's time to bring personalities back. We asked him to explain how we got to where we are and how we get back.

From its birth in the 1920s, radio programming was synonymous with personalities. Bing Crosby, Bob Hope, Amos n' Andy, Edgar Bergen and Charlie McCarthy and Jack Benny were welcomed into households across the nation via that radio in the living room. Later, as rock 'n roll was emerging in the 1950s and '60s, a new generation of personalities in the form of top-40 DJs sprang from the clear-channel AM stations around the country. Alan Freed, Hunter Hancock, Robin Seymour, B. Mitchell Reed, Dick Biondi and Arnie Ginsburg entertained a growing audi-

ence of teenagers, especially ones listening in car radios.

"All of those DJs had a 'schtick,' something that made them unique," said Ramsey. For some, it was howling into

toward the music. This trend reached its peak with the birth of syndicated radio formats in the early 1980s, such as "Music of Your Life" and "Hot Hits." Now, in his view, announcers had little

"Listeners are creatures of habit. They have their favorite stations, and they stick with them. They're not very likely to discover your new format or personalities unless you vigorously promote them on several media channels."

— Mark Ramsey

the microphone like a caged animal; others used sound effects or had conversations with imaginary sidekicks. Common to many was an anti-authority tone that only increased through the 1960s.

Beginning in the late 1970s and continuing into the '80s, the number of formats increased, and the emphasis began to shift away from the personality and

to do but play a tightly formatted playlist and read liner notes word for word. Nothing more, nothing less.

"It became a reliable recipe for success," said Ramsey, "getting by on the easy and the familiar."

Today, we are surrounded online and on mobile devices by music channels that are essentially jukeboxes.

"Radio can't succeed by building a better jukebox," Ramsey feels, "because listeners will just seek out another jukebox that has no commercials."

For radio to thrive, he feels it needs to differentiate itself from the jukebox by doing something entirely different, namely bringing back the personalities.

"It's a long road back, but it's only going to get longer. Now is the time to start, while radio is still in every car, and while it is still listened to by most everybody." It's also key to do this before personalities are forgotten altogether.

"I did a flash study with 1,000 consumers in the U.S. aged 18-54," said Ramsey. "And I asked this question: 'What are the names of the *three* most famous DJs, hosts or shows you can think of from radio, online radio, satellite radio or podcasting?' Among the most-recalled were Ryan Seacrest and Howard Stern. All the rest of the names on the list were of people who are dead. Will Howard Stern be the last, best-known, non-political air talent?"

Ramsey said that other forms of media and entertainment have rejuvenated themselves with younger talent. "Late-night television hosts, 'Saturday Night Live' and the film industry are all running with younger talent. So where's the next generation of radio personalities?"

That being said, what makes a great



New: NAB Post-Sees & Debriefing

A FREE WEBINAR NOW AVAILABLE ON DEMAND

New products and new technologies are one of the best reasons to go to the spring NAB Show. But maybe you can't get to Las Vegas; or maybe you didn't have nearly enough time to walk the floor and see all that glittering new gear.

Radio World solves the problem with our new post-show **NAB Post-Sees & Debriefing**.

- Dozens of new products
- Features, prices and availability dates
- From microphones to transmitters
- Observations by Radio World's veteran editors and engineering contributors

Brought to you by:



RADIOWORLD



TO VIEW THE ARCHIVE, VISIT: <http://radioworld.com/webinars/13>

radio personality?

"A 'personality' isn't simply a voice on the air," says Ramsey. "For a personality to matter, he or she must be a genuine talent, someone with 'star power' who magnetizes an audience because he or she is just that good. Anything less is just a voice."

What does the road back look like? First, he feels, management needs to recognize the problem and be willing to spend some serious money to find and retain good talent.

"They would easily spend \$100,000 on the technology to upgrade a signal, rather than spend that money on getting the best talent in town. That's a shame because no one listens to the radio for

technology; they listen for the personalities because the songs are freely available everywhere now."

Second, management has to actively seek out new talent. "I would feel sad and morose if I thought there was no new talent to be found, but that's just not the case." He feels there is a huge pool of untapped talent doing top-quality podcasts.

Third, these new personalities need to be promoted heavily. "Listeners are creatures of habit. They have their favorite stations, and they stick with them. They're not very likely to discover your new format or personalities unless you vigorously promote them on several media channels."

The importance of talent is not lost on

all stations. Ramsey points to legendary rocker WMMR(FM) in Philadelphia (a Mark Ramsey Media client) as a place where talent is valued; he notes for example that it still uses a live announcer on the overnight shift. Ramsey asked WMMR Program Director Bill Weston to explain why.

"Personality is everything," he said. "If you're running 13 songs an hour and 6 minutes of spots on the overnight, then you're not as good as Pandora. Those guys are running 15 songs per hour with no spots and the element of surprise. The ability of talent to make that connection with someone who is feeling isolated or unappreciated is very powerful. Those people will tell the tale of why WMMR

has this guy on overnights who connects the dots between the music, them and their lifestyle."

Ramsey concludes that it's all really an exercise in marketing strategy.

"Programming is not about doing what everybody else is doing; it's about doing what nobody can do as well, namely managing a well-run radio station that emphasizes localism with engaging, live personalities."

Comment on this or any story; write to radioworld@nbmedia.com with Letter to the Editor in the subject line.

Tom Vernon is a longtime contributor to Radio World. Find more of his articles by searching keyword "Vernon" on radioworld.com.

PRODUCTS & SERVICES SHOWCASE

A Great Place to Advertise!

RADIOWORLD

Radio World's **Products and Services Showcase** provides a perfect medium for marketing your products and services.

For more information contact
minderrieden@nbmedia.com
 212-378-0400 ext. 523
 to request a media kit.

Thanks for Reading Radio World!

NOT out of the blue
Bext's loyal customer base did not come out of the blue. It's a 30-year track record of high quality RF broadcast equipment, experience & 24/7 customer service. Call Bext today to find out what Bext can do for you.



888 239 8462
www.bext.com

GORMAN REDLICH DIGITAL ANTENNA MONITOR



The Model CMR is a state of the art instrument of unequalled accuracy and stability. With typical modulation, the CMR's true ratio readout is a factor of 10 more stable than instruments that measure normalized amplitude. With a 15kc IF for the measuring circuit, this monitor is ideal for diplexed arrays.

- True Ratio reading. Non-Reference and Reference amplitudes are separately measured and divided electronically to give an accurate digital reading.
- Stable, accurate phase reading with automatic phase sign.
- Amplitude or True Ratio may be selected for measurement with a front panel switch.
- Dual Surge Protection.

GORMAN REDLICH 257 W. Union Street Athens, Oh 45701
 Phone: 740-593-3150 jimg@gorman-redlich.com
www.gorman-redlich.com

World Radio History

You're Here!



...and so are the potential buyers for your products and services.

Radio World is a great place to find things for your business, and a great place for prospects to find you!

To advertise, call Michele at:
 212-378-0400 ext. 523
 or email: minderrieden@nbmedia.com.

DISC-OVERY*(continued from page 1)*

create a good recording.

"When the station got its first recording equipment in '98–99, Pro Tools was state of the art. I wasn't getting the credit for good-sounding recordings as much as Pro Tools was. We used the same system for 13 years, and later in that time period people thought I was a genius for making old equipment sound good," he said.

"When we got the new gear in 2012, I thought, 'Now am I back to being an idiot with good gear?' I say, 'It's the ear, not the gear.'"

This adage is particularly true in mixing for radio, where the limiting and compression doesn't allow one to hear the outcome until it's actually broadcast. By listening to and evaluating the broadcasts over time, Cicerelli has learned to mix for radio.

THE SET

It is not only the broadcasting that is a challenge to live recording, but the station location itself.

Musicians set up in the main common area of the station, the library, with two-story ceilings and walls lined with records. It also happens to be the main entrance and thoroughfare. Though this is not the controlled environment of a recording studio, Cicerelli has learned to make it work. He lets the high ceilings and sound absorption of the vinyl-lined walls do their part to finesse the acoustics. The drums are placed in a large carpeted area, the only place they fit. They are miked the same way as the rest of the band: close-miked, not overmiked, allowing the bleed through from the other microphones to augment the drum sound.

From there, he uses a basic setup that is tweaked depending on the band. The system consists of a Pro Tools HD native system with a Focusrite ISA828 eight-channel preamp, a Curtis Technologies eight-channel preamp and a Focusrite 2802 mixer/control surface. He starts with a 24-channel session template set up in Pro Tools, and uses Waves Renaissance EQs, V series EQs, Focusrite D3 compressors and Waves NLS Non-Linear Summer for plug-ins. On the master channel he uses Waves C4 multiband compressor and IK Multimedia Bus Compressor



and a Waves L3 Multimaximizer multi-band peak limiter. For the Field Report release, which is an acoustic solo performance by Porterfield, Cicerelli used a Shure SM58 microphone for the vocals and went direct with the acoustic guitar using a Waves PS22 Stereo Maker plugin to give the guitar a stereo image.

HUMAN SKILLS

Beyond the sound, a good recording depends on getting a good performance out of the musicians, which again, requires good technology paired with good human skills. "A great recording of a bad performance isn't worth anything," Cicerelli said.

Before the performance, bands send him information about instruments, gear and members. At the performance, each musician gets Elite Core Audio PM-16 16-channel headphone mixers — which Cicerelli says are absolutely amazing — and control over his or her headphone mix. Cicerelli does his part to put the bands at ease by being prepared and at ease himself.

"If they don't see that, they have something else to think about, and it takes away from their performance," he said. He plays back the sound check so they can hear what they sound like, and this, he finds, ensures a level of comfort and confidence as well.

"That the band knows they are going out live adds an intangible to the performance that gives them energy to play really well. Certain bands are just live bands," he said. "I'm of the belief bands should be better live than on a record."

In most cases, Cicerelli needs not do much to adjust the recording when the performance is done. Bands get a copy of the performance when they walk out the door of the station, and some have released those recordings as part of larger works or as EPs. WMSE has put out 13 CD collections of in-studio

performances.

WMSE plays a variety of music spanning all genres, so Cicerelli has recorded everything from garage bands to eight-foot vibes to traditional African percussion. His formal training as a keyboardist gives him an appreciation

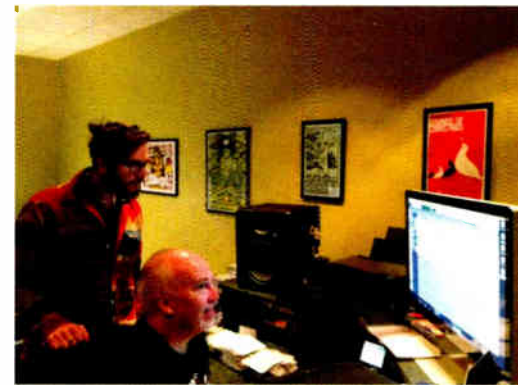

Chris Porterfield and Billy Cicerelli (seated) work on a cut from the album.

He has the ability to draw people in with the melody and then, as a writer, he gives something lyrically there for you once you're drawn in."

In the end, Cicerelli credits a symbiotic relationship between himself and the musicians who grace WMSE's studio with performances with the quality of the recording experience. "It's important to never think you know everything," he said. "[With my experience] I can both teach the musicians who come in and learn from them. The majority of people either like a song or they don't."

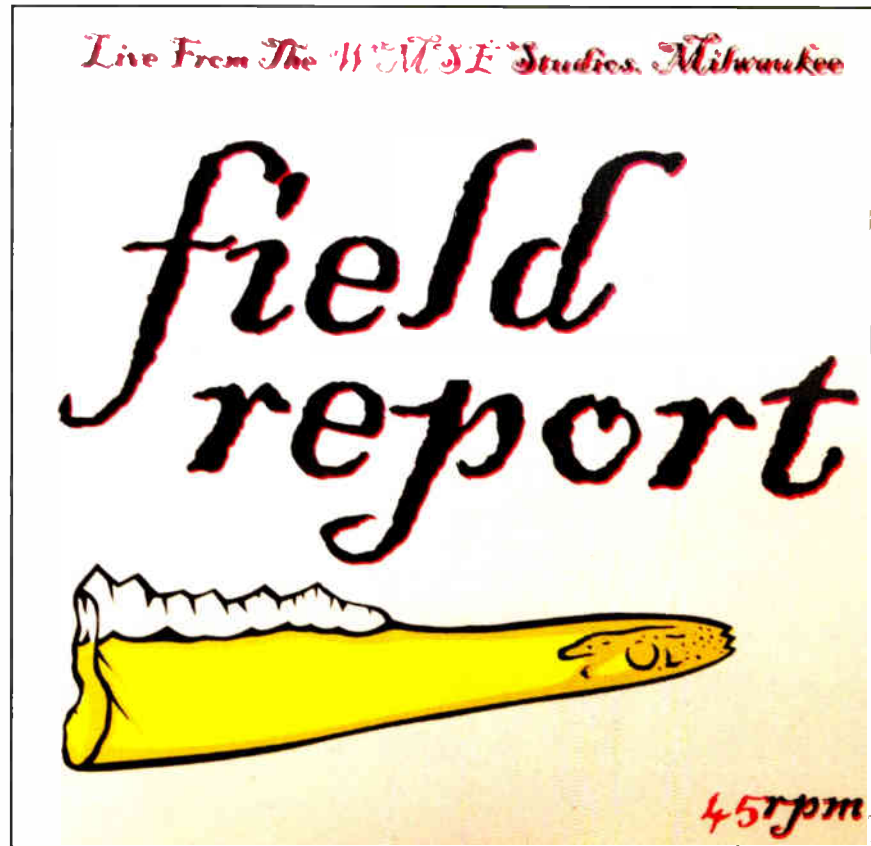

The album art featuring a deer jawbone was designed by local Milwaukee artist Von Munz.

and respect for the performers he works with, from eclectic ensembles to a man and his guitar.

"I want the band to sound the way they want to sound, not how I think they should sound," he said. "I'm just letting people sound as great as they are. Chris [Porterfield] has control of his dynamic.

It's a one or a zero. They never say, 'If they used a different mic on the snare I'd like the song more.'"

Stephanie Kilen is a staff member of WMSE in Milwaukee.

We're looking for your radio production stories. Email ideas to bross@nbmedia.com.



BAY COUNTRY BROADCAST EQUIPMENT

BUY - SELL - TRADE
Your #1 Source
For Quality Used Radio Broadcast Equipment

View The Latest List Online at: <http://www.baycountry.com>
Or call and we will fax it to you.

7117 Olivia Rd., Baltimore MD 21220
Toll Free: 877-722-1031 • FAX 443-596-0212 • E-mail: sales@baycountry.com

ACOUSTICS

Acoustics First
-SOUND AND NOISE CONTROL MATERIALS-
Toll-Free Number: **888-765-2900**
www.AcousticsFirst.com

**ANTENNAS/
TOWERS/CABLES**

FCC COMPLIANCE
TOWER SIGNS
AM & FM Tower Signs
Tower Registration Signs
Standard & Custom Wording
Guy Wire Protectors - Antenna Tags

ANTENNA ID PRODUCTS
antennalid@msn.com
E-mail us for a free PDF catalog
610-458-8418 www.antennalid.com

WANT TO SELL
CCA IM8000G 107.9, 50129.9 hrs, like new; 4-Bay Jampro antenna deicers, gd cond; 4-bay Shively circul polar FM antenna, manual. sherry@prtcnet.org, or 859-533-5635.

**AUDIO PROCESSING
(INCLUDES ON-AIR)**

WANT TO BUY
Teletronix LA-2A's, UREI LA-3A's & LA-4's, Fairchild 660's & 670's, any Pultec EQ's & any other old tube compressor/limiters, call after 3PM CST - 214 738-7873 or sixtiesradio@yahoo.com.

**AUTOMATION
EQUIPMENT**

WANT TO SELL
It's free and it has been expanded. The only cost is to keep us informed as to how the system is performing and let us know how you are using it. DIY-DJ, is a Linux based radio automation system and now sports a record scheduler (DIY-DJ-RECORDER) which allows you to schedule the recording of a network or any other program for replay later as well as a basic logging

system. Beside these additions the system schedules music, does voice tracking (ALWAYS hit the vocal), create a shell, live assist, exact time events, join satellite feeds, automated temperature announce, do unattended remote events and more. Call (406) 679-0527 or email krws@digitaldevelopment.net for a copy today.

**MICROPHONES/
HEADPHONES/
SPEAKERS/AMPS**

WANT TO SELL
1934 RCA 77A double ribbon microphone, originally used by Arthur Godfrey at WFBR Baltimore. 100% perfect condition. Contact Bill Cook, 719-684-6010.

RCA 77-DX's & 44-BX's, any other RCA ribbon mics, on-air lights, call after 3PM CST, 214 738-7873 or sixtiesradio@yahoo.com.

MISCELLANEOUS

WANT TO SELL
Radio broadcasts of Major League Baseball, NFL, and some college football games that are on cassette tapes, approx 100 to 125 games, time period of entire collection os from the 1950's - 1970's, BO. Must purchase entire collection. Contact Ron, 925-284-5428 or ronwtamm@yahoo.com

**STOP
AM RADIO INTERFERENCE**

with a plug-in modem/telephone RF filter from:
K-Y Filter Company
3010 Grinnel Place
Davis, CA 95618
(530) 757-6873



www.ky-filters.com

Model AM-1 is for AM Broadcast Band radio interference.
Model RF-1 is for Short Wave, Ham Radio, CB etc.

CONSULTANTS

OWL ENGINEERING, INC.
Consulting Communications Engineers
5844 Hamline Ave. N., Shoreview, MN 55126
651-784-7445

- AM/FM/NCE Applications
- Allocation and Upgrade Studies
- Pre-Purchase Inspections
- ANSI and NRSC Measurements
- Tower Detuning
- Intermodulation Studies
- Radiation Hazard Evaluation and Measurements
- AM Directional Array, Design, Tuning and Proof using Method of Moments

Fax (651) 784-7541 E-mail: info@owleng.com "Member AFCEE"

GRAHAM BROCK, INC.
BROADCAST TECHNICAL CONSULTANTS
Full Service From Allocation to Operation AM/FM
Field Work: Antenna and Facilities Design
Over 45 years engineering and consulting experience
912-638-8028
202-393-5133
www.grahambrock.com

Doug Vernier
Telecommunication Consultants
Broadcast Engineering Consulting
AM/FM/TV/LPTV/DTV
Custom mapping service
Frequency searches
Propagation prediction
FCC application preparation

VSoft
Software for your PC
(800) 743-3684
www.v-soft.com

ROTRON BLOWERS AND PLATE BLOCKERS, new & rebuilt for Elcom, Horris, CCA, CSI, McMorrin, Goodrich Ent. 11435 Monderson St. Omaha, NE 68164 402.493.1886 Email: charlesgoodrich44@gmail.com.

FOR THE BEST PRICE & 24 Hr service on transmitting tubes & sockets/ports, new & rebuilt coll Goodrich Ent. or 402-493-1886 day or night, www.goodrichenterprises.com.

WANT TO BUY

Collector wants to buy: old vintage pro gears, compressor/limiter, microphone, mixing consoles, amplifiers, mic preamps, speakers, turntables, EQ working or not, working transformers (UTC Western Electric), Fairchild, Western Electric, Langevin, RCA, Gates, Urei, Altec, Pultec, Collins. Cash - pick up 773-339-9035 or ilg821@aol.com.

2" plastic "spot" reels 6.5 or 8" diameter, as used for quad video. Wayne, Audio Village, 760-320-0728 or audiovlg@gte.net.

Equipment Wanted: obsolete, or out of service broadcast and recording gear, amplifiers, processing, radio or mixing consoles, microphones, etc. Large lots preferred. Pickup or shipping can be discussed. 443-854-0725 or ajkivi@gmail.com.

Broadcast Equipment Exchange

For more information, ask Michele at 212-378-0400 x523 or minderrieden@nbmedia.com

RADIOWORLD

I'm looking for San Francisco radio recordings from the 1920's through the 1980's. For example newscast, talk shows, music shows, live band remotes, etc. Stations like KGO, KFRC, KSFO, KTAB, KDIA, KWBR, KSF, KOB, KCBS, KQW, KRE, KTIM, KYA, etc, I will pay for copies... Feel free to call me at 925-284-5428 or you can email me at ronwtamm@yahoo.com.

Looking for a broadcast excerpt of a San Francisco Giant's taped off of KSFO radio from 1959, interviews with Willie Mays, Dusty Rhodes & some play by play excerpts, also features a homerun by Willie Mays and Felipe Alou stealing second base, running time is 18:02, also looking for SF Giants games and/or highlights from 1958-1978 also taped off KSFO Radio. Ron, 925-284-5428 or ronwtamm@yahoo.com.

Looking for KFRC signoff radio broadcast from 1930 Andy Potter, running time is 0:22 & also the KLX kitchen the program guest is Susanne Caygill, a discussion of women's affairs with a long promotion for Caygill's appearance at a local store. Anne Truax,

DISTRIBUTOR DIRECTORY

The following distributors serving the broadcast industry would be glad to help you with any of your requirements.

**CORNELL-DUBILIER
MICA CAPACITORS**
FROM STOCK

**JENNINGS VACUUM
CAPACITORS**
FROM STOCK

**HIGH ENERGY CERAMIC
CAPACITORS**

SURCOM ASSOCIATES
5674 El Camino Real, Suite K
Carlsbad, California 92008
(760) 438-4420 Fax: (760) 438-4759
e-mail: link@surcom.com web: www.surcom.com

Susanne Caygill, running time is 13:44. Ron, 925-284-5428 or email ronwtamm@yahoo.com.

Looking for KTIM FM radio shows from 1981-1984 if possible unscoped. R Tamm, 925-284-5428 or ronwtamm@yahoo.com.

**RECEIVERS/
TRANSCIVERS**

WANT TO SELL
Free sample SCA decoder. 417-881-1846.

**RECORDING &
PLAYBACK HARDWARE**

WANT TO BUY
Large or small collections of 16" transcriptions or 12" transcriptions, not commercial LPs. Bill Cook, 719-684-6010.

Schnader telescriptions 16 mm musical films produced in the early 50 s. Bill Cook, 719-684-6010.

Standard Short-tune series. Bill Cook, 719-684-6010.

**TAX DEDUCTIBLE
EQUIPMENT**

Donations Needed: All Volunteer, Non-profit Low Power community radios stations need Equipment. Will offer tax deduction letter, You determine donation value, You will pay shipping. Equipment shared between three Wisconsin stations. Looking for Mics, Mixers, field equipment, etc. You name it. Email: Dan@WIECradio.org.

Broadcast Equipment Exchange

"BEE" in the habit of selling your used equipment here!



Contact Michele for details at
212-378-0400 ext. 523 • minderrieden@nbmedia.com



Rebuilt Power Tubes 1/2 the cost of New!

Se Habla Español

ECONCO

Se Habla Español



Tel: 800-532-6626 Web: www.econco.com
Intl +1-530-662-7553 Fax: +1-530-666-7760

TRANSMITTERS/EXCITERS/TRANSLATORS

TRANSCOM CORPORATION

Serving the Broadcast Industry Since 1978
Transmitters and Broadcast Equipment for Radio & Television

Used FM Transmitters

1.3 KW	HO 2006	Harris Digital Z6HD, solid-state
3.5 KW	2000	Harris Z3.5CD, solid-state
3.5 KW	2006	Harris Z3.5, solid-state
5 KW	1995	Harris HT5CD
5 KW	1999	Harris Z5CD, solid-state
5 KW	2006	Harris Z5, solid-state, unused
7.5 KW	2002	Harris Z7.5CD, solid-state, S PH
8 KW	1997	CCA FM8000G, single phase
10 KW	1998	Harris Z10CD, solid state
20 KW	1989	BE FM20B
27.5KW	1988	Continental 816R-4B, New CE SS IPA
30 KW	1988	Harris FM30K
35 KW	1991	BE FM35B

Used AM Transmitters

Please see our website or contact us for current listing

Exciters & Miscellaneous Equipment

BE FC30, SCA Generator
Bird Model 8936, 10 kW air-cooled RF Load
Harris N + 1 Controller
Marti ME 40, FM exciter
MCI 4 Port 1-5/8" Coaxial Switch

Please visit our website,
www.fmamtv.com, for additional listings.



HARRIS nautel

CROWN BROADCAST

TV Transmitters- Analog and Digital
Used FLD TV Transmitters** Axcera
Rohde & Schwarz Harris Maxiva

New TV Transmitters- Analog and Digital
OMB, Rohde & Schwarz and Technalogix
VHF and UHF TV Antennas
(10 W to 10 KW) TV STL

800-441-8454 • 215-938-7304 • FAX: +1-215-938-7361

www.fmamtv.com • E-mail: transcom@fmamtv.com

RETUNING & TESTING AVAILABLE • CALL US FOR A QUOTE!

WANT TO SELL

NiCom 100/s Stereo 100 Watt
Exciter/Transmitter, frequency
agile from front panel, brand
new, never used, \$1700.00; also
various production equipment.
krek_fm@yahoo.com or 918-
625-2515 if no answer leave
message.

www.radioworld.com

Q • How do I advertise
in Radio World?



A • Call Michele at 212-378-0400 x 523
or email: minderrieden@nbmedia.com

**AM Ground
Systems Company**
Complete AM Ground
System Services
amgroundsystems.com
866-22RADIO

HAVE YOU SEEN US LATELY?
YOUR MESSAGE MATTERS
New additions to our executive team
and a significant infusion of capital
are enabling operational growth,
product quality improvements, and
more responsive customer service.
For competitively priced transmitters
that are made in the USA, go to
www.ptekpower.com
PTEK
FM BROADCAST TRANSMITTERS

EMPLOYMENT

POSITIONS WANTED

Are you a small market station need-
ing a good nuts & bolts engineer in
the Los Angeles area? I will make your
station shine! CET, fully FCC Licensed.
Available for Full/Part-time/Contract
work. Available immediately. Mitchell
Rakoff, 909-446-6820, mitchellrakoff@yahoo.com.

format(s) preferred. Send details about
your management opening to: radiogm@hotmail.com.

Mike Essen-podcaster "The Mike
Essen Show" Articulate, witty, excel-
lent debater, conservative, original,
and insightful. Movie expert, sports fan,
all around great guy! 305-389-0023 or
mikeessen@hotmail.com.

searching for a weather forecast, sports
and traffic report, writing team to join.
Patricia, 214-952-9768 or patricia_lynn_williams@yahoo.com.

Extremely knowledgeable and artic-
ulate racing writer/talk show host
Adam Amick is available for shows,
correspondent, features, etc. Check out
www.bleacherreport.com for samples.
Call 214-384-5812 or email: adam@rubbinsracingshow.com.

Experienced radio station manager
seeks new management opportu-
nity. More than 39 years experience in
radio. Willing to relocate. Family-friendly

Enthusiastic broadcaster seeks posi-
tion in News Broadcasting. Self-starter

Buying Or Selling
Used
Equipment?
You're in the right place!
RADIOWORLD
Broadcast Equipment Exchange

READER'S FORUM

PUBLIC INTEREST

Responding to "Why Do We Need Public Files, Anyway?" Feb. 11 issue:

One of the most important aspects of serving the public need isn't even measured by the FCC: What does a station do when a real disaster or emergency occurs?

Does it interrupt normal programming, cancel commercials and go wall to wall with relevant information? Or does the unattended computer just keep cranking out the hits and spots?

Market size doesn't seem to matter. Big groups have been guilty of this as they have stretched thin and couldn't man stations if they wanted to. Many "mom and pop" stations simply don't have the resources, while stations controlled and fed by satellites are so out of touch with what's happening locally that they wouldn't know of a problem until hours if not days later.

Although measuring such coverage in any quantitative way would be difficult, it would be a more meaningful metric to demonstrate that they are truly operating "in the public interest."

*Ken A. Starcher
Cuyahoga Falls, Ohio*

LIMIT THE AUTHORIZATION

Dear Commissioner Pai: I read with dismay that Chairman Wheeler is opposed to an application window for AM licensees to apply for FM translators. His view, as I understand it, is that he is opposed to "government giveaways" to special classes of applicants.

The impetus so far has been to open an application window where only AM licensees are eligible. No window will occur with the chairman's opposition. As an AM station and FM translator owner, I fear that the chairman's opposition may foil all the hard work you have been doing trying to give AM stations a hand up.

I agree with Chairman Wheeler's philosophy on this issue, but AM broadcasters need relief! My comments on AM revitalization proposed an FM translator alternative that should be acceptable to Chairman Wheeler, while still providing AM translator help: Don't limit eligibility to apply; limit the authorization.

Open a window for new and major change FM translators where anyone may apply, but the translatorS that are authorized should be limited to rebroadcasting AM primary stations for perhaps 10 years, or possibly permanently. This will provide the critical lifeline for AM stations, while avoiding the philosophical problem of a "giveaway" to a selected class of applicants.

Licensees can apply for translators and construct them if they have the capital to do so, but many AM licensees have no risk capital available.

Small entrepreneurs like myself could also build translators and lease or sell them to AM licensees for their stations, reducing risk for the licensee. An entrepreneur could perhaps LMA the AM station to be rebroadcast over his translator. There are many scenarios for the ways that third parties may help AM relief.

Please rephrase the AM translator window discussion so that it is no longer a "government handout" but a fair way to issue authorizations.

The plan should help solve a problem, not give away government resources to special interests.

A window for FM translators that may only rebroadcast an AM primary station is redress for the former FCC rule that unfairly banned FM translators from rebroadcasting AM stations until May 2009. Opening the window to all applicants resolves the argument that it is a plum for any special interest.

*Edward (Ted) Schober, PE
Consulting Engineer
Radiotechniques Engineering LLC
Haddon Heights, N.J.*

I DO REMEMBER THE VANGUARD

Loved Ed Montgomery's story on the Gates Vanguard transmitter of the 1960s ("Remember the Vanguard," April 22 issue).

I bought one of the first ones in summer of 1966 for KBEW(AM) in Blue Earth, Minn., after receiving an FCC power increase to 1 kW. Stanley B. Whitman was the Gates salesman who convinced me the Vanguard was the finest transmitter ever made, with its single tube.

He also sold Vanguards that summer to Paul Olson at KLEM in LeMars, Iowa, and Bob Reimers at KBRK in Brookings, S.D. I got to know these station owners because the Vanguard 1 turned out to be tough to keep on the air.

I picked up our Vanguard at a freight house in Hannibal, Mo., as Gates could not deliver out of Quincy due to some tax situation. KBEW engineer Bill Merrill eagerly tore out our Gates 250 GY, unwrapped the Vanguard and hooked it up with an electrician on hand. It would not tune our shunt-fed antenna, and after four hours of trying, we hurriedly uninstalled it, putting back 250GY by 6 a.m. sign-on.

The 4CX3000A needed a huge blower to cool and had a huge roar. It ran hot, so hot I spent several hundred dollars redoing ventilation and used it to heat our building in winter. Vanguard needed a non-varying antenna system, which our shunt was not. Thus it shut down quickly during even minor thunderstorms.

In 1976, we needed \$100K worth of equipment for an FM in Morris, Minn. Gates and Collins wanted that order. Galen Hassenger succeeded Stan Whitman as Gates sales rep and was pressing hard for the order. OK, I said, throw in a new Gates BC 1H for KBEW, and you've got it. Galen said, "They won't do that." I said to Galen, "Tell 'em I've operated a Vanguard 1 for 10 years and need relief." Gates agreed, and that's how I got rid of my Vanguard 1.

*Paul C. Hedberg
Hedberg Group, Retired
Naples, Fla.*



KBEW engineer Bill Merrill moves out the Vanguard 1, returning it to Gates in 1977.

LPFM ACTIVISM

Gee, what a shocker! (Not!) Who didn't see this coming, right?

Even before the recent LPFM floodgate opened, the FM band was already jam-packed just about as tight as it could be, certainly in the larger markets. Then the low-power advocates and licensees were given even more special favoritism by getting elimination of third-adjacent protection/minimum spacing for full-power operators, commercial and non-com alike, and all without having to pay annual license fees like the larger radio broadcasters.

And now the low-power crowd wants less-low power, as well as second-adjacent protection destruction, making a bad situation still worse for the full-power licensees, who invested or paid millions of dollars for their FM signals, and who get billed annually, thank you very much, by the FCC!

Yes, I believe that many LPFM licensees are very genuine and legitimate in their mission of serving segments of the local community whose interests are not being met by the big broadcasters. But we are certainly witnessing politically motivated activists, with a much bigger agenda, who want to keep moving the goal posts in a way that departs further and further from the original purpose of the LPFM service. So, mark my word: Next, the LPFM activists will be asking for full commercial status, to compete directly with the full-power owners and operators who have played by the rules, fair and square, all along. Oh, and, naturally, 250 watts won't be enough.

Yes, there are true community interests, and then there are special interests, that could care less about operating in the *public* interest. We need to call an end to their charade and return to a "rule of rules." Enough with the special interests' games!

*Robert E. Lee
Lee MediaWorks LLC
Austin, Texas*

READER'S FORUM**AM NEEDS PROGRAMMING REBOOT**

I am still amazed at how many think that AM is already dead and their pet solution to the problem is one size that fits all.

AM has problems in many areas, no doubt, and some type of solution is needed for those situations.

AM has become an afterthought in many markets and the programming reflects that. Solution: Compelling programming. We just did that with a IKW AM, that we just purchased, and it is working quite well, thank you!

Digital modulation on the current AM band with the IBOC digital modulation scheme is a non-starter for technical and financial reasons.

Migration to VHF is a viable option for those whose situation calls for it. My solution is that those that wish to migrate be given the opportunity to do so.

Those that wish to stay with the current analog modulation scheme should then be given A: More power, and B: Loosened restrictions regarding nighttime skywave interference.

No matter what solution is finally agreed on there will be casualties. Many are just hanging on and this will cause them to cease operation. This is normal business evolution. One-size fits all means only a few get what they really need, and the rest have to make do with what they were given.

*R.V. Zeigler
Director of Engineering
Nebraska Rural Radio Association
Lexington, Neb.*

WRITE TO RW**SEND A LETTER TO THE EDITOR:**

Email radioworld@nbmedia.com with "Letter to the Editor" in the subject field. Please include issue date.

SMOAK, NOT A WANNABE

I was forwarded a story from your email newsletter about WBSC(LP) in Bamberg, S.C. I was taken aback when I read the statement, "The station is focused on oldies/local information and fulfilling the dreams of its wannabe broadcast manager."

This comment apparently was directed at station manager Bob Smoak, who was featured in the article linked to the newsletter. Was this a simple poor choice of words or a mean-spirited dig?

"Wannabe," by definition, is "one who wishes to be/do something but lacks the talent or qualifications." Sure, I get the whole "using snark to generate clicks" mentality; but Bob is certainly no wannabe.

He visualized his dream of bringing radio back to Bamberg, and didn't stop working toward that goal until it became reality. WBSC is the very essence of LPFM ... giving radio back to the community. LPFM is a direct response to the homogenized chum that has become radio in the last quarter century. Bob Smoak is a 50+-year veteran of the industry, and is a consummate professional. WBSC is generating the kind of community support that many LPFMs can only dream of having. Oh no! A man living his dream. Quick! Tear him down!

Have a look at Bob's new control room, shown here.



The control room of WBSC(LP), which was completed in April 2015. Hand crafted from cedar in a 19th century former hotel. Harris Oasis console ... and yes, you can play vinyl on the air.

He visualized his dream of bringing radio back to Bamberg, and didn't stop working toward that goal until it became reality. WBSC is the very essence of LPFM ... giving radio back to the community. LPFM is a direct response to the homogenized chum that has become radio in the last quarter century. Bob Smoak is a 50+-year veteran of the industry, and is a consummate professional. WBSC is generating the kind of community support that many LPFMs can only dream of having. Oh no! A man living his dream. Quick! Tear him down!

Have a look at Bob's new control room, shown here.

*Jack Anthony
President
Fort Mill Community Radio Foundation
Charlotte, N.C.*

Editor's note: Jack Anthony is the contract engineer who helped set up the control room and put WBSC(LP) on the air.

RADIOWORLD
The News Source for Radio Managers and Engineers

Our readers have something to say:

"Radio World has helped keep Keightley Company abreast of a fast-changing industry since the days of 'hollow state.'"

Jim Keightley
President
Keightley Company
White Salmon, Wash.

HEIL SOUND
www.heilsound.com

ADVERTISER INDEX

This listing is provided for the convenience of our readers. Radio World assumes no liability for inaccuracy.

PAGE	ADVERTISER	WEB SITE/URL
5	AudioScience Inc.	www.audioscience.com
25	Bext, Inc	www.bext.com
7	Comrex Corporation	www.comrex.com
1, 15	ENCO	www.enco.com
21	ESE	www.es-web.com
25	Gorman Redlich Mfg	www.gorman-redlich.com
30	Heil Sound, Ltd.	www.heilsound.com
19	Henry Engineering	www.henryeng.com
13	Inovonics Inc:	www.inovonicsbroadcast.com
11	Moseley Associates	www.moseleysb.com
6, 20, 26	Nautel Ltd.	www.nautel.com
31	Radio Show	www.radioshowweb.com
18	Ram Broadcast Systems	www.ramsyscom.com
4	Studio Hub	www.studiohub.com
9	Tieline Technology	www.tieline.com
2, 16-17, 32	Wheatstone Corporation	www.wheatstone.com

RADIO SHOW

Produced by NAB and RAB

BOLD IDEAS **TURN IT UP** **PROFITABLE STRATEGIES**

Sept. 30 – Oct. 2, 2015 | Atlanta, Ga.

Get your hands on the hottest ticket
in radio and register for the
2015 Radio Show!

HIGHLIGHTS INCLUDE

All-new schedule

Supercharge your experience
with new events that give you the
most bang for your buck

Brand new programming

for young professionals,
plus a discounted
registration rate

Tons of cutting-edge technology
and networking opportunities in
the Marketplace Exhibit Hall

Tuesday night's Kickoff Party
Arrive on September 29 to
start your stay off right

Registration sponsored by:  Marketron

Kickoff party sponsored by:  Mix

Visit RadioShowWeb.com to learn more and **register today!**

 facebook.com/radioshowweb  [@radioshowweb](https://twitter.com/radioshowweb) | [#radioshow2015](https://twitter.com/radioshowweb)

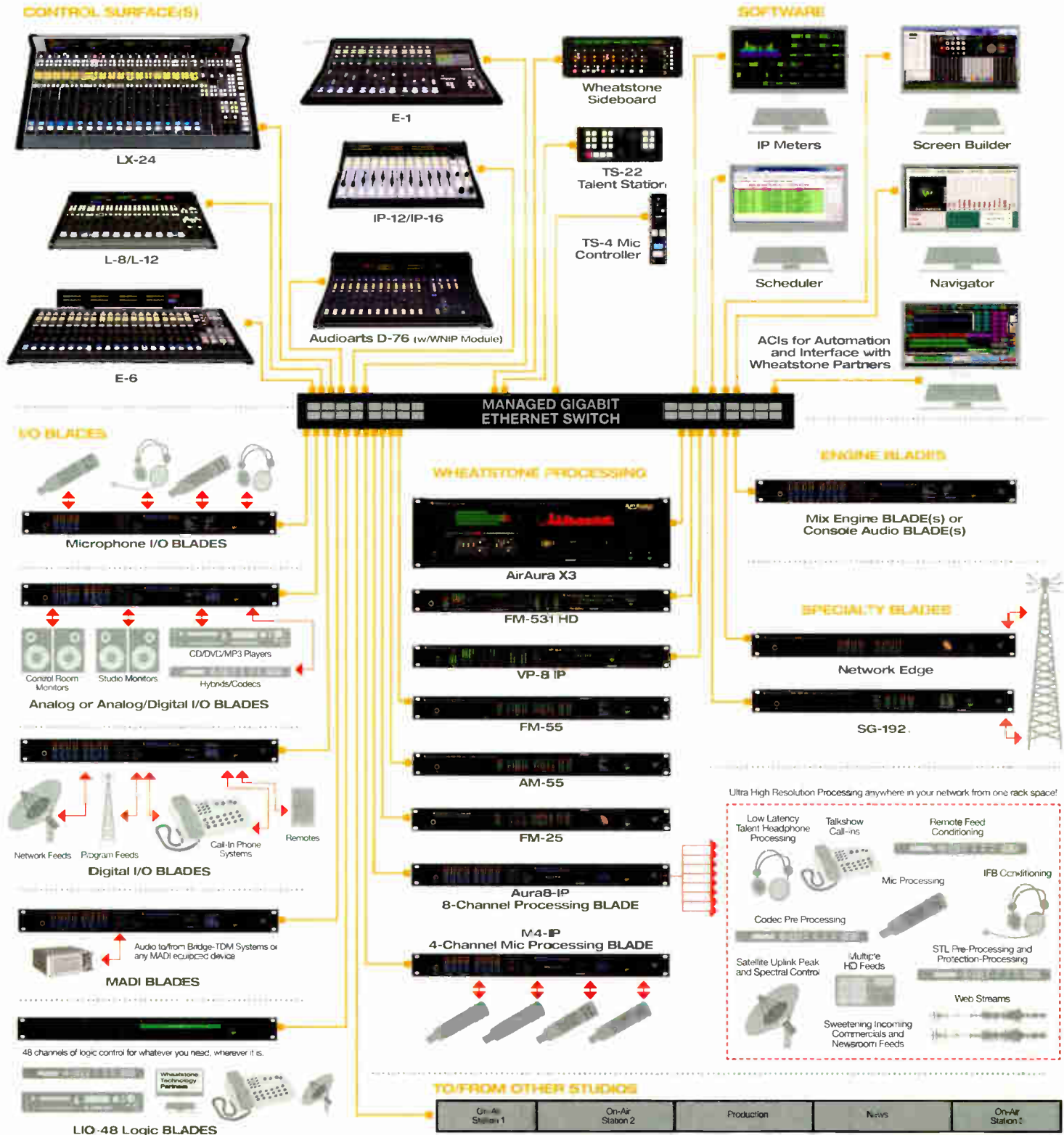

The Complete IP Audio Network Ecosystem

It's all here. Everything you need (or will) for your IP Audio Network system. Gigabit distributed intelligent network - a comprehensive audio toolkit complete with mixers, dynamics, processing, clip players and much more, PLUS an integrated control layer that provides full, interactive control between all gear - everything on the network - including our partners' equipment. And it's AES-67 compatible. Plug and play with CAT-6 cable and you are ready to go. And go. And go....

