



BROADCASTING

NEWSPAPER

TELEVISION

VISION AND RADIO

U S Air Force
Air University Lib
63-8999
Serial Acq Section
Maxwell AFB Ala

5A2753
3Y 10C
11515
MAY64 CIN

AUGUST 5, 1963

A big year for TV
as the new season

Senate group how stations
cal races 60

Daytime sales for the coming season mount
at the TV networks 36

NAACP bid for Negroes in crews rejected
by two studio unions 42

COMPLETE INDEX PAGE 7



The Kansas State Network and its flagship station

KARD-TV

CHANNEL 3 WICHITA

announce the appointment of

Edward Petry & Co., Inc.

as exclusive National Representative
effective August 1st

GREATER *

Wheeling-Steubenville
Ohio Valley Market

* *GREATER*
because WTRF-TV's
NEW TALLER TOWER
has replaced our
old smaller tower.
Note these
impressive *NEW*
WTRF-TV market
area figures . . .

**529,300
TV HOMES**

**\$5,369,000,000
TOTAL SALES**

It all adds up
to profitable
results for
advertisers.
For WTRF-TV
availabilities,
call VP Bob
Ferguson or SM
Cy Ackermann,
Area Code 304,
232-7777.
National Rep.,
George P.
Hollingbery Co.



Equipped for network color
WHEELING, WEST VIRGINIA

A buyer's guide to Raleigh/Durham television

There are a number of important facts you need to remember when you buy North Carolina television.

Remember that WRAL-TV, Raleigh, is the only ABC-TV affiliate between Richmond, Va., and Columbia, S. C. Unlike other stations, there's no overlap, no duplication.

Remember that WRAL-TV, Raleigh, has achieved an unusual identity with the community and the market. A recent attitudes and opinion study by Central Surveys, Inc., shows that 61% of the people prefer WRAL-TV for news and weather.

Remember that WRAL-TV, Raleigh, has consistently pioneered in programming in this market. No other station in the market carries as much local news. No other station in the market editorializes daily.

Remember that WRAL-TV, when combined with the leading station in Charlotte, reaches 87% of the population, 88% of the buying power in North Carolina. No other two-station combination gives you so much for so little.

Remember that WRAL-TV is the only station located in the state's leading food brokerage center. In addition, Raleigh is ranked as the state's second largest shopping center by N. C. officials.

Remember that WRAL-TV can give you more homes for less money. Total homes mean little unless related to cost-per-thousand. With

a rate card that includes pre-emptible AA spots, WRAL-TV can deliver nighttime audiences for as little as \$1.44 per thousand homes.

Check this offering, prepared on request from an advertiser. It is not a trumped-up schedule, but a typical 12-plan proposal. Look it over. Like it? See H-R. They'll prepare an up-to-date proposal for you.

WRAL-TV 12-PLAN PROPOSAL*			
12-plan, 12 spots in one week. Cost, \$633.00. Total homes delivered, 439,800. Cost per thousand homes, \$1.44. Homes delivered per \$100 invested, 69,479.			
Day	Time	Length/Class	Homes
MON	6:30-6:45 PM	:60 / A	54,400
	9:30 PM	:20 / AA	57,400
TUE	9:45 AM	:60 / D	10,000
	10:00 PM	:20 / AA	56,900
WED	6:30 PM	:60 / A	52,800
	11:20 PM	:60 / D	13,600
THU	9:45 AM	:60 / D	10,000
	6:30-6:45 PM	:60 / A	54,900
FRI	9:45 AM	:60 / D	10,000
SAT	10:00 PM	:20 / AA	54,000
	11:30 PM	:60 / D	25,100
SUN	9:00-9:30 AM	:60 / D	40,700

*This actual 12-plan proposal prepared for Pine State Creamery Co., Raleigh, N. C., January 25, 1963. Homes-delivered statistics based on NSI, Nov.-Dec., 1962. Cost analysis based on WRAL-TV rate card #7.

WRAL-TV, RALEIGH, N.C.
ABC Television—Represented Nationally by H-R

IF YOU
WANT
TO
BUY
THE
LION'S
SHARE
OF THE
FOUR
STATION
DALLAS
FORT WORTH
MARKET



Look at these figures

	Metro Share*	KRLD-TV Total Homes*
Jan '63	38%	96,400 (41% SIU)
Feb/Mar	37%	87,600 (40% SIU)
Mar/Apr	39%	80,400 (42% SIU)
Apr/May	39%	75,200 (41% SIU)
May/June	40%	80,200 (41% SIU)

*ARB Market Report, 9 a.m.-Midnight, Monday-Sunday: Jan; Feb/Mar; Mar/Apr; Apr/May; May/June, '63.

... indicating that for the 6 months ending June 1963, KRLD-TV's average Metro Share is 39% and that Channel 4 delivers an average of 41% of the Total Homes in the 4-STATION MARKET AREA for this broad period.

Month after month, season after season, the lion's share of the Dallas-Fort Worth market is yours with KRLD-TV. See your ADVERTISING TIME SALES representative.



represented nationally by
Advertising Time Sales, Inc.



THE DALLAS TIMES HERALD STATIONS

Channel 4, Dallas-Ft. Worth

Clyde W. Rembert, President



MAXIMUM POWER TV-TWIN to KRLD radio 1080, CBS outlet with 50,000 watts

Prospects on pay TV

Not all of its clients agree with Stanford Research Institute's bullish attitude toward pay-TV prospects (CLOSED CIRCUIT, July 29). At least one of some 60 SRI clients who attended private briefing in New York last week doubts that sufficiently attractive programing has been devised—or even dreamed of—to attract enough daily revenue to make system economically feasible.

Report's anticipation of \$2 billion yearly revenues for pay TV looks especially staggering. But skeptics after SRI session in New York last week acknowledged that if SRI is right in foreseeing 15 million homes linked up by mid-1970's (at initial cost of \$2 billion), then it's conceivable that relatively low level of home usage might cover operating costs and turn profit. Even so, they figured that if SRI had used more realistic home spending figure, it would have projected loss rather than profit. They're clearly inclined to side with report's hedging observation that in practice, pay-TV programing may not prove as attractive as it seems apt to be.

Metromovements

To be announced by Metropolitan Broadcasting (Metromedia): transfer of Albert P. Krivin, vice president and general manager of KMBC-TV Kansas City, to KTTV(TV) Los Angeles, recently acquired by Metromedia, and appointment of Mark Wodlinger, vice president and general manager, WZZM-TV Grand Rapids, Mich., as Mr. Krivin's successor in Kansas City. Bennett Korn, president of Metropolitan Broadcasting and directing head of television properties, was on West Coast last weekend.

Mr. Wodlinger's successor at WZZM-TV, ch. 13 outlet which has operated on interim basis since Nov. 1, 1962, is Harold Sundberg, former sales manager. He has previously managed WMBD-TV Peoria, Ill.

Ownership limits

Four members of FCC are said to favor consideration of reducing number of radio and television stations any person or company may own. Subject was discussed at last Thursday's FCC meeting and is almost certain to come up again after commission returns from August vacation. Some commissioners think present limits of 21 stations—seven each for AM, FM and TV—may be too high. Four who asserted interest in question last Thursday were Chairman Henry and Commissioners Loevinger, Bartley and Cox.

In recent weeks there's been per-

CLOSED CIRCUIT®

sistent report that FCC staff has been working on draft of proposed rule-making to reduce permissible multiple ownership of VHF television stations from five to three. No confirmation, however, has been obtainable. Commissioners who last week showed interest in exploring question were at variance on approaches to take.

Escape hatch

Stations report that something new has been added to Pulse Inc.'s letters soliciting their participation in Pulse audience surveys. It's line saying "Pulse shall not be liable for any loss or injury caused by the neglect or other act of said company or any of its officers, agents or employes in procuring, collecting, tabulating, computing, analyzing and communicating said information." Pulse officials say this disclaimer, designed to protect against clerical and similar errors, has always been written into Pulse contracts, has been added to solicitations as matter of precaution.

There's no indication whether Pulse decision to insert disclaimer in letters of solicitation was influenced by recent announcements of government surveillance over ratings users. Federal Trade Commission has said it would hold users responsible for accuracy of surveys as well as their use in sales and promotion. FCC has said it will consider FTC actions in deciding whether stations are operating in public interest.

Swezey leaving

Robert D. Swezey intends to leave his job as director of National Association of Broadcasters code authority when his \$40,000-a-year contract expires next Oct. 15. Mr. Swezey doesn't need job; he has substantial income from sale of minority holding in WDSU-AM-TV New Orleans. Word is that he and LeRoy Collins, NAB president, have been at odds over philosophy of radio and television codes and their operation. When he leaves code job, he'll take it easy for while, may eventually return to station operation or practice of law.

Following the news

CBS News is consolidating its Atlanta and Dallas bureaus into new, larger one at New Orleans, effective this month. With WWL-AM-TV New Orleans news staff it will share new building that will be news headquarters for both. Dan Rather will be chief correspondent. New Orleans move is

part of series of reassignments and expansions by CBS News, mostly timed to coincide with start of CBS-TV's new half-hour news show.

Among other changes planned by CBS News, Charles Kuralt, South American correspondent, becomes chief correspondent of enlarged Los Angeles bureau, with Robert Schakne as bureau manager there. Bernard Eismann moves from Chicago to New York, and Hughes Rudd, who has been chief of Atlanta bureau, takes over expanded Chicago bureau. Arthur Bonner, formerly in India, more recently in special shows in this country, has gone to South America temporarily, pending appointment of permanent successor to Mr. Kuralt.

Other side

FCC commissioners and possibly FTC and other government officials will get chance at radio business orientation in Radio Advertising Bureau's management conferences, scheduled in September and October. RAB has invited one or two to each conference, with idea that they'll see detailed presentation on radio today, hear broadcasters discuss radio problems, then be given opportunity to talk and answer—or ask—questions. Five of seven FCC members have accepted.

Splurge in syndication

Westinghouse Broadcasting Co., which is on spree of producing programs for syndication, is understood to be taping series titled *The Meaning of Communism* for showing on its own stations and for sale to other outlets. Series will cover 30 half-hours exploring various facets of Communism and 10 are said to have been completed. WBC also produced *Steve Allen Show* and *Mike Douglas Show*, plus large number of specials for syndication. It has just signed for television rights to a stage play opening on Broadway next fall (see page 56).

Trade winds

Tribulations of National Association of Broadcasters are not necessarily peculiar to that trade association. Number of trade groups, both among media and in manufacturing, are having internal convolutions growing out of membership complaints over character of service and increasing costs of operation. One trade association (National Business Publications) recently deposed its president and others in both electronics and electrical manufacturing, report what they regard as "seasonal unrest."

WE'VE GOT A WAY WITH WOMEN

Month after month, Channel 2 is the No. 1 spot on the dial for Detroit's women viewers, specially the 18 to 30 year olds. To lick any sales problem you may have with this big-buying group, call your STS man.

18 to 39 Year Old WOMEN VIEWERS

Sept., 1962 thru June, 1963*

WJBK-TV	43%
STATION "B"	25%
STATION "C"	17%
STATION "D"	15%

*12N-6 PM M-F Avg.
ARB Sept., 1962—May-June, 1963



MILWAUKEE WITI-TV	CLEVELAND WJW-TV	ATLANTA WAGA-TV	DETROIT WJBK-TV	TOLEDO WSPD-TV	NEW YORK WHN	IMPORTANT STATIONS IN IMPORTANT MARKETS STORER BROADCASTING COMPANY
MIAMI WGBS	CLEVELAND WJW	LOS ANGELES KGBS	DETROIT WJBK	TOLEDO WSPD	PHILADELPHIA WIBG	

STORER TELEVISION
SALES, INC.
Representatives for all
Storer television stations.

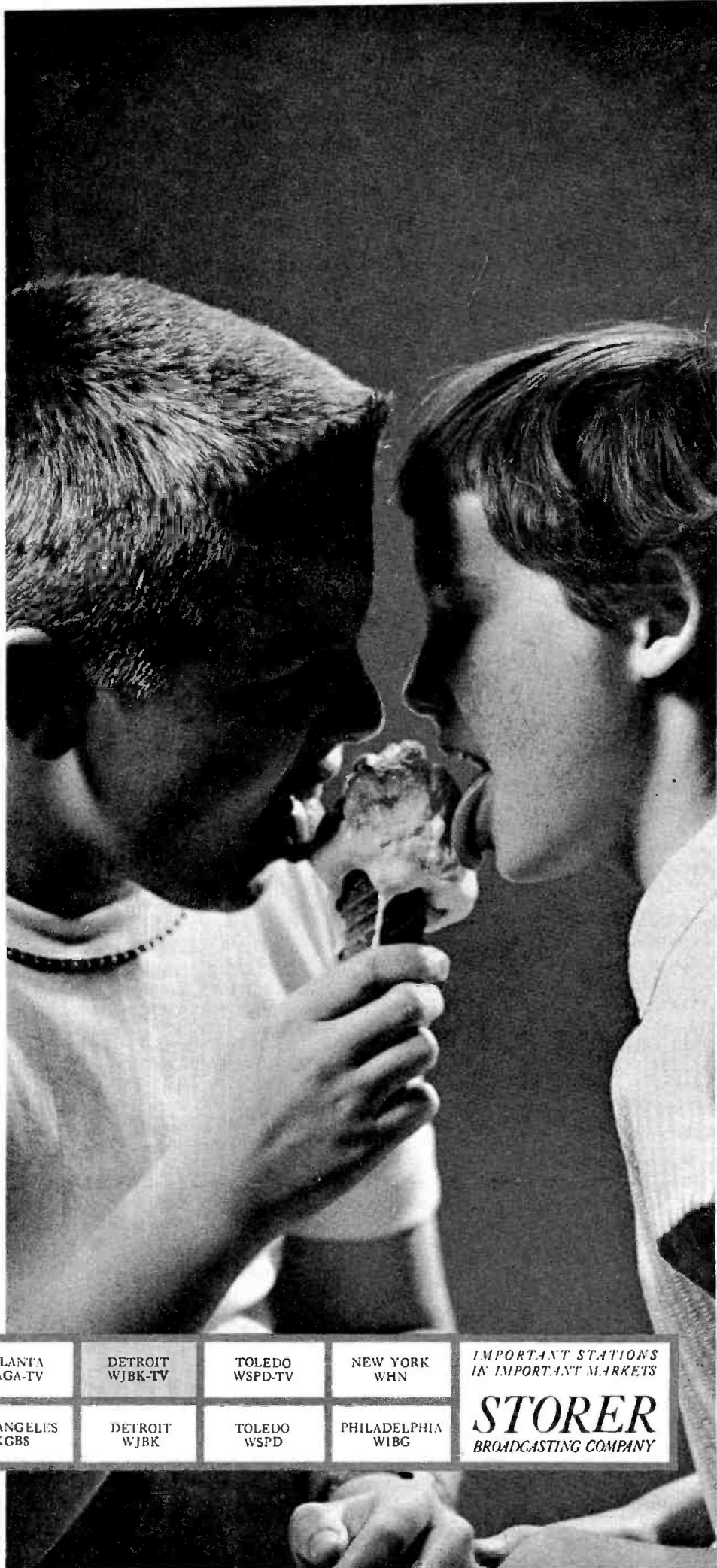

WEEK IN BRIEF

TV commercials for the fall season are hitting peak in production with an increase in color spots. Outside producers, agency executives view situation optimistically, foresee nominal increase in production costs. See . . .

COMMERCIAL MAKERS BUSIEST EVER . . . 31

Schedule changes are few and smiles are brighter as the networks find daytime television is getting strong advertiser response. The fourth-quarter selling pace is far ahead of last year. See . . .

NETWORK'S HAPPY DAYTIME . . . 36

Without running to FCC, broadcasters handled some complaints of candidates for Senate in 1962. Broadcasters' experience now becomes part of Senate record in hearing on Section 315's suspension next year. See . . .

CANDIDATES' COMPLAINTS . . . 60

Two IATSE unions give a cold shoulder to NAACP demands for a Negro in each crew, ignoring a plea for acceptance of the proposal by union president. Seven locals plan vote at next membership meeting. See . . .

NAACP DEMANDS HIT SNAG . . . 42

Editorializing conferees hear note of hope in Representative Harris's prediction that Congress won't pass restrictive legislation this year. Broadcasters agree FCC and Congress should keep hands off. See . . .

EDITORIAL FREEDOM ENDORSED . . . 46

FCC concedes a 'minor' point and changes language of its statement reminding broadcasters of application of fairness doctrine in controversial community issues. It's major point to NAB. See . . .

'ALL' BECOMES 'OTHER' . . . 68

Pay TV test in Hartford, Conn., turns up some "encouraging and enlightening" facts, according to a report on the first year of the test on WHCT(TV). Fee system also seen as benefiting commercial TV. See . . .

O'NEIL, WRIGHT HAPPY . . . 50

Broadway and TV will get even closer this fall when Westinghouse (Group W) offers new three-act dramatic play at same time show opens in New York theater. Commercials will be used at natural breaks in the play. See . . .

TELEVISION ON BROADWAY . . . 56

ABC and would-be applicants for VHF drop-ins oppose the proposal of the Association of Maximum Service Telecasters that FCC Commissioner Kenneth Cox refrain from further participation in the proceeding. See . . .

LET COX VOTE . . . 70

Television Bureau of Advertising reports that coffee advertisers increased their TV billings in 1962 by 7%, from \$40.3 million to \$43.1 million. Spending by 11 biggest brands dropped, some 5%. See . . .

COFFEE TV SPENDING UP . . . 34

DEPARTMENTS

AT DEADLINE	9	GOVERNMENT	60
BROADCAST ADVERTISING	31	INTERNATIONAL	82
BUSINESS BRIEFLY	38	LEAD STORY	31
CHANGING HANDS	78	THE MEDIA	78
CLOSED CIRCUIT	5	MONDAY MEMO	20
COMMERCIALS IN PRODUCTION	38	OPEN MIKE	24
DATEBOOK	14	OUR RESPECTS	109
DATELINE	84	PROGRAMING	42
EDITORIAL PAGE	110	WEEK'S HEADLINERS	10
FANFARE	86		
FATES & FORTUNES	88		
FILM SALES	50		
FINANCIAL REPORTS	80		
FOR THE RECORD	95		



BROADCASTING THE BUSINESSWEEKLY OF TELEVISION AND RADIO

Published every Monday, 53d issue (Yearbook Number) published in November by BROADCASTING PUBLICATIONS INC. Second-class postage paid at Washington, D. C., and additional offices.

Subscription prices: Annual subscription for 52 weekly issues \$8.50. Annual subscription including Yearbook Number \$13.50. Add \$2.00 per year for Canada and \$4.00 for all other countries. Subscriber's occupation required. Regular issues 50 cents per copy. Yearbook Number \$5.00 per copy.

Subscription orders and address changes: Send to BROADCASTING Circulation Dept., 1735 DeSales Street, N.W., Washington, D. C., 20036. On changes, please include both old and new addresses plus address label from front cover of magazine.



Billion Dollar Spender

... that's North Carolina's Golden Triangle Market. Over \$1 Billion in annual retail sales—and it's yours to tap when you buy the strong, 33-county coverage of WSJS Television.

North Carolina's
Golden
Triangle

NO. 1 MARKET IN THE NO. 12 STATE

WSJS
TELEVISION 

WINSTON-SALEM / GREENSBORO / HIGH POINT

Represented by Peters, Griffin, Woodward

SWEENEY SPEAKS OUT ON RAB, BUNKER

Decries radio code as one of NAB's 'worst mistakes'

Kevin B. Sweeney, president of Radio Advertising Bureau for nine years until his resignation last February, let fly Friday (Aug. 2) at his successor, Edmund C. Bunker, and RAB's current plan for \$200,000 radio audience research methodology study.

In speech prepared for delivery at New Mexico Broadcasters Association, Mr. Sweeney, now president of John Poole Broadcasting Co., also said he was now free to call National Association of Broadcasters' radio code "among the worst mistakes that NAB has made in this generation." He said key to radio's service is "almost strictly economic," and scoffed at notion that a station's commercial load reflects against its service to its community.

Mr. Sweeney said RAB's current plan for radio research methodology study "is either one of the most naive plans in RAB's history or one of the most cynical, because there is historical evidence" that major research projects rarely pay their way in new advertising sales.

Answers Are There ■ "Without spending a dollar," he said, "just by studying the dozens of research projects RAB has undertaken for specific advertisers in the past years but never published, they [RAB] can find the facts about how many listen, when, and to whom."

Mr. Sweeney said that "to see Ed Bunker identify himself with this research project as the path out of the desert convinces me that he is as remote from the day-to-day realities of selling radio to national and important retail

accounts as he was during the seven months when we were trying to ride the same horse." This apparently referred to period when Messrs. Sweeney and Bunker were both at RAB, as president and president-elect, respectively.

Mr. Sweeney said RAB had learned over 10-year period that radio will never beat TV and newspapers on basis of total audience figures. Current project's \$200,000, he claimed, "should be devoted to persuading General Foods and Lever Bros. and the nation's retailers to spend some money with us."

'Not In Touch' ■ RAB officials, advised of Mr. Sweeney's remarks, suggested he was "not completely in touch with industry developments" because, they said, "he isn't describing the same project we're working on."

They said need for study like theirs "has been endorsed enthusiastically by everyone we know of" and "if Kevin visits advertising agencies and advertisers he will observe how much enthusiasm has been generated."

"We are seeking the knowledge that will allow accurate and complete measurements of radio audiences on a continuing basis—not just a study providing figures on total audience," RAB said.

An NAB official said association would have no comment until text of Mr. Sweeney's comments have been studied. He said NAB had not seen statement.

Former Kennedy adviser faces late tax charges

James M. Landis, former special assistant to President Kennedy on regulatory agencies, and who was highly critical of FCC operations, pleaded guilty in federal court in New York Friday (Aug. 2) to five counts of late filing and payment of income taxes for years 1956-60.

Mr. Landis, who was represented by Dean William Warren of Columbia Law School, said all taxes due, along with penalties and interest, were paid as soon as amount was calculated. Charges are misdemeanors carrying maximum penalty of year's imprisonment and \$10,000 fine for each count.

U. S. Attorney Robert M. Morgenthau said charges were brought because Mr. Landis didn't meet government standard of "voluntary disclosure."

Mr. Landis, who once was Harvard

Law School dean, joined Kennedy staff shortly after 1960 election and remained as White House advisor through most of President Kennedy's first year in office. He now practices law in New York.

TTC sale signed, Time to get KERO-TV

Contracts totaling about \$38.5 million for acquisition of Transcontinent Television Corp.'s TV and radio stations in five markets were signed Friday by Taft Broadcasting, Midwest Television and Time Inc.

David C. Moore, TTC president, said sales are subject to FCC approval and to favorable rulings from Internal Revenue Service, "among other conditions."

Total sales price, based on about \$21.20 per share of TTC stock, is largest in broadcasting history. There are 1,817,000 shares outstanding.

Sales follow pattern indicated when negotiations were first disclosed (BROADCASTING, April 15, 22), except for Time Inc.'s entry into picture.

Taft Broadcasting, headed by Hulbert Taft Jr., acquires WGR-AM-FM-TV Buffalo, WDAF-AM-FM-TV Kansas City, Mo., and WNEP-TV Scranton-Wilkes-Barre, Pa. Taft owns WKRC-AM-FM-TV Cincinnati, WTVN-AM-FM-TV Columbus, Ohio; WBRC-AM-FM-TV Birmingham, Ala., and WKYT-TV Lexington, Ky.

Midwest Television, headed by August C. Meyer, acquires KFMB-AM-FM-TV San Diego. Midwest owns WCIA-TV Champaign, Ill., and WMBD-AM-FM-TV Peoria, Ill.

Time Inc. acquires KERO-TV Bakersfield, Calif., a UHF station. Originally Midwest Television had been negotiating for Bakersfield as well as San Diego. Announcement said Midwest "stepped

Stylish stogie spots

What are said to be two of higher priced commercials of recent TV history have been completed by General Cigar Co. for its White Owl brand, at cost of \$50,000 for pair. General Cigar through Young & Rubicam went to Paris to produce one-minute commercials which star French comedian Fernandel and authentic Parisian backgrounds. Commercials will be introduced in September on first NCAA football game (CBS-TV) and ABC-TV's *Fight of The Week*.

New effort to balk Faulk

Appeal has been filed by Vincent W. Hartnett to upset New York State Supreme Court jury libel verdict in favor of TV-radio entertainer John Henry Faulk. Jury awarded Mr. Faulk \$3.5 million in damages against Mr. Hartnett, Aware Inc. and late Laurence A. Johnson. Estate of Mr. Johnson reportedly has settled with Mr. Faulk for \$175,000 and is not participating in Mr. Hartnett's appeal.

aside" when Time offered to buy Bakersfield property on same terms Midwest had offered. Time said it had been negotiating with TTC since 1961. Time owns KLZ-AM-FM-TV Denver, WOOD-AM-FM-TV Grand Rapids, Mich., KOGO-AM-FM-TV San Diego, WTCN-AM-TV Minneapolis and WFMB-AM-FM-TV Indianapolis.

Time Inc. said it was paying \$1,565,000 for KERO-TV. Spokesman for TTC and Taft said it was impossible to break down individual prices on other stations pending further computations.

TTC retains WDOK-AM-FM Cleveland, valued at 80 cents per share.

Mixed blessing bestowed on editorials by Celler

"Efforts to preclude editorializing on the air should be resisted," said Representative Emanuel Celler (D-N. Y.) Sunday (Aug. 4). But he added "unless television and radio fashion a way to permit fair editorial comment . . . these media will never reach the maturity that mass communication demands in the public interest."

In statement prepared for *Congressional Conference* on WOR-TV New York, Representative Celler urged broadcasters to encourage audience to comment on editorials "as is done in the newspapers through the publication of 'letters to the editor.'"

Noting "dwindling number of newspapers," Representative Celler, chairman of House Judiciary Committee, said "it would be in the nature of an important public service to have editorial comment."

Representative Celler's committee held hearing this spring on concentration of ownership of news media. Hearing recessed when committee took up civil rights legislation.

Another meeting set on Negroes in radio-TV

Employment of Negroes on live radio and TV broadcasts in Hollywood is to be discussed Friday (Aug. 9) at meeting of broadcasters with representatives of National Association for the Advancement of Colored People, James Tolbert, president, Hollywood-Beverly Hills chapter, NAACP, said Friday (Aug. 2).

Demands which NAACP will present were to be determined over weekend at meeting of Mr. Tolbert with Herbert Hill, national labor secretary of NAACP, in New York. Also to be decided then is plan to file proceedings with National Labor Relations Board for decertification of Set Designers Local 847 of International Alliance of Theatrical & Stage Employees, which allegedly has held membership application of Negro on file for three years

WEEK'S HEADLINERS

Charles G. Mortimer Jr., program manager of TV department at William Esty Co., elected to newly created post of VP for television programming. Assuming new position today (Aug. 5), Mr. Mortimer continues as head of TV programming but in broadened executive capacity. He joined Esty agency in 1957 following duties with ABC-TV as program production manager and supervisor of on-the-air programming. Prior to positions at ABC Mr. Mortimer was with CBS-TV as associate director and producer-director.

without action. If taken, it will be first such action by NAACP against any Hollywood craft union. Meeting with broadcasters, Mr. Tolbert said, is being arranged through Hollywood chapter of American Federation of Television and Radio Artists.

Segregation feared in use of HEW funds

Three applications for federal funds to build educational TV stations in two southern states have run into opposition of National Association for the Advancement of Colored People. Department of Health, Education and Welfare Friday (Aug. 2) gave NAACP 30-day extension of deadline for commenting on applications.

Association, in seeking delay, said stations involved are located in areas which practice school segregation and "since it is most likely that these TV facilities will be used in connection with existing educational facilities, it is imperative that guarantees be secured that will insure colored students their full par-

ticipation in the benefits to be derived from the use of these facilities."

Existing TV facilities are being used to promote segregation, NAACP charged, and asked applicants for federal grants be required to pledge equal opportunity for Negro children. NAACP said it is conducting investigation of three applications. HEW, which handles ETV grants of federal funds, extended deadline until Aug. 28.

Three requests involved, with amount of money sought, are WHRO-TV (ch. 15) Hampton, Va. (\$129,943 to build new studios); South Carolina Educational TV Commission for new stations in Charleston (channel 7, \$59,000) and Greenville (channel 29, \$285,000).

Individuals to have say in NAB fall sessions

Individual broadcasters will have greater participation in eight fall conferences of National Association of Broadcasters in October-November than they have in past. This is major decision to date in early planning for sessions, which begin Oct. 14 in Hartford, Conn. NAB staff met last Thursday (Aug. 1) in first full-scale planning session. In past years, staffers of association have dominated programs with few broadcasters appearing. It was at fall conference in Portland, Ore., last November that NAB President LeRoy Collins made his now-famous remarks on cigarette advertising.

GM's first move into spot TV

Buick will crack spot TV ice for General Motors this year, is to buy prime 20's in top 25 markets for five-six weeks beginning late September as starter, it was learned in Detroit Friday (Aug. 2). Dodge starts buying spot television this week; Chrysler cars expected soon also.

British home TV recorder not due until '64

Delay in development of new low-cost home TV tape recorder for distribution in U. S. by Telcan Ltd., Nottingham, England, was reported last week. Meanwhile interest grew about possible impact of new equipment, especially on future of pay TV systems.

Telcan, which expected to have recorder on U. S. market before end of 1963, may have to wait until late 1964 before system is suitably adapted for American use, it was said. List price of unit in Britain will be about \$182.

Recorder, called "Telcan," reportedly permits home taping and replay of TV shows. Unit even allows

viewer to record program on different channel than one he is viewing. Company says unit will also enable user to play homemade TV tapes.

Equipment weighs 15 pounds, dimensions 17 inches by 2 inches, with 4 inch protrusion for motor housing. It will be available as separate unit or one which can be built into TV set. Sound and vision are recorded simultaneously on standard quarter-inch magnetic tapes.

Similar equipment has been developed in U. S. but none suited for marketing. RCA demonstrated "here-see" tape recorder in 1958 but high cost and tape speed problem have prevented its commercial production.

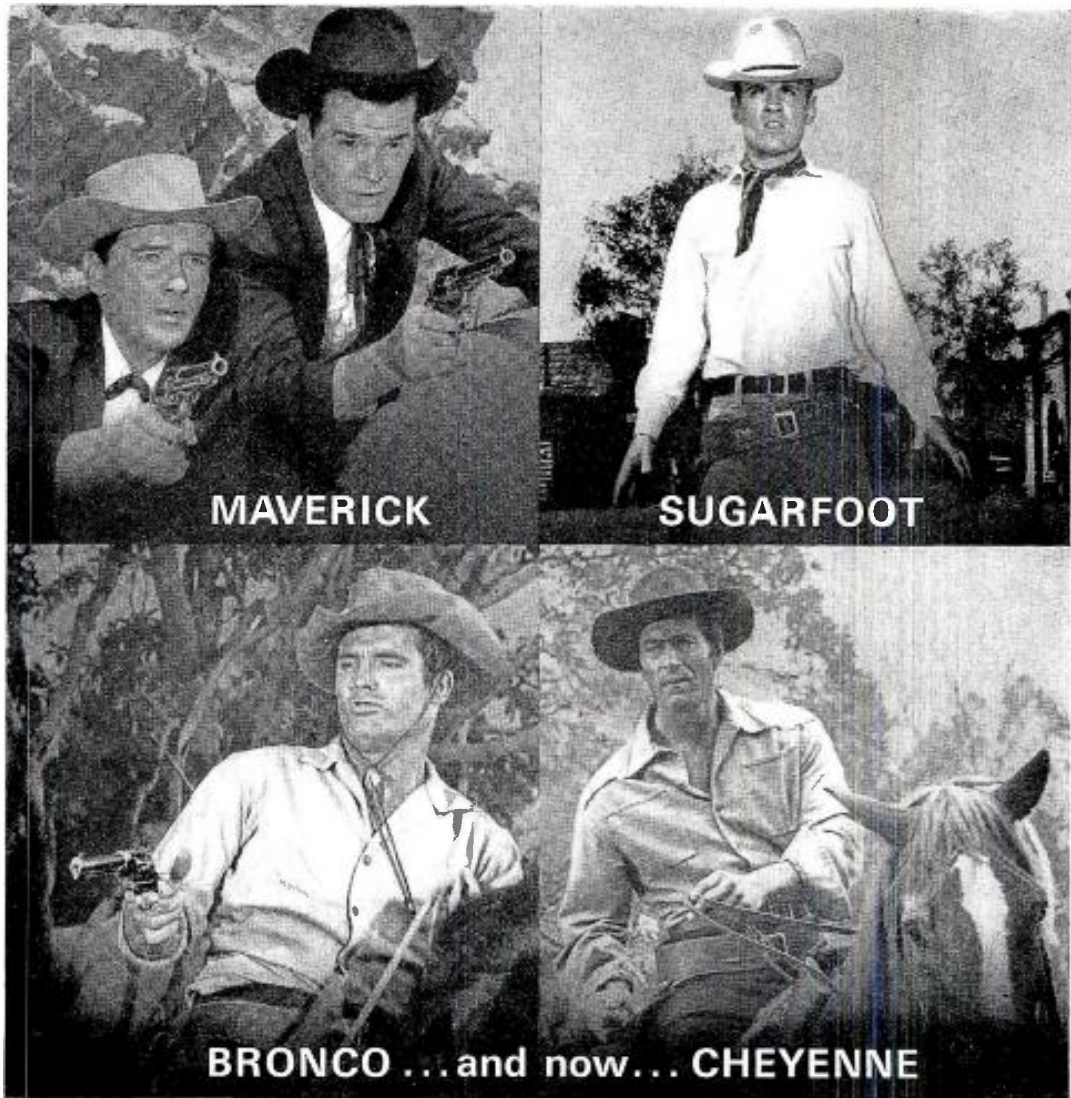

MAVERICK

SUGARFOOT

BRONCO ... and now... CHEYENNE

THE GREAT WESTERNS ARE **H**HOURS

One sure-fire way to beef up late-afternoon and early-evening television ratings is to program a Western series. And you'll find most of the great television Westerns are hours. Take *Maverick*, *Sugarfoot*, and *Bronco*, for examples. They're all going great guns on an off-network basis.

REACH 35% MORE HOMES

During February and March 1963, a total of 65 hours of these three Westerns were running each week in various markets between 5:30 and 7:30 P.M. weekdays. Com-

pared to programs on the same stations, same time periods, a year ago, these 65 Western hours reached 35% more homes.*

REACH MORE ADULTS, TOO

More important, the three Westerns reached 48% more men and 24% more women. Now, with the hour-long *Cheyenne* series ready for fall start, stations and advertisers have even greater flexibility in opportunities to reach more adults. Look into the great Westerns. You'll find most of them are hours... and they're also ours.

*ARB Reports: Feb/Mar 1963 and 1962

WARNER BROS. TELEVISION DIVISION 666 Fifth Avenue, New York 19, N.Y., Circle 6-1000



ALSO: HAWAIIAN EYE · SURFSIDE 6 · THE ROARING 20'S · BOURBON STREET BEAT · LAWMAN

What makes a great salesman?

Daredevil auto racer...staff driver for General Pershing...America's top flying ace in World War I. Capt. Eddie Rickenbacker might have been considered a glamorous doer rather than a positive thinker. But when he became head of Eastern Air Lines in 1934, he recognized that flying was destined to become a commercial business rather than a sport, and that the big job was to sell the *idea* of flying to everyone — its safety, its time-saving advantages, its tangible value to business.

Then Capt. Eddie became a great salesman. He lived and breathed commercial aviation. Seldom seen in his office, he was constantly on the wing, talking to service groups, women's clubs, chambers of commerce, sales conventions — anyone who would listen to the fascinating story of air transportation. Today's vast network of domestic and international airlines owes much to Capt. Eddie's persuasiveness, and to his belief in and knowledge of his product.

Likewise, the success of the Storer stations stems from continuous work in the field to gain greater understanding of people's needs and desires. Because they know their markets, Storer stations can plan their programming to meet community tastes and preferences, backing up this knowledge with efficient operation and a watchful eye for the advertiser's interests that turns more listeners and viewers into *buyers*. In Miami, Storer's great salesman is WGBS, an important station in an important market.

LOS ANGELES KGBS	PHILADELPHIA WIBG	CLEVELAND WJW	NEW YORK WHN	TOLEDO WSPD	DETROIT WJKB
MIAMI WGBS	MILWAUKEE WITI-TV	CLEVELAND WJW-TV	ATLANTA WAGA-TV	TOLEDO WSPD-TV	DETROIT WJKB-TV



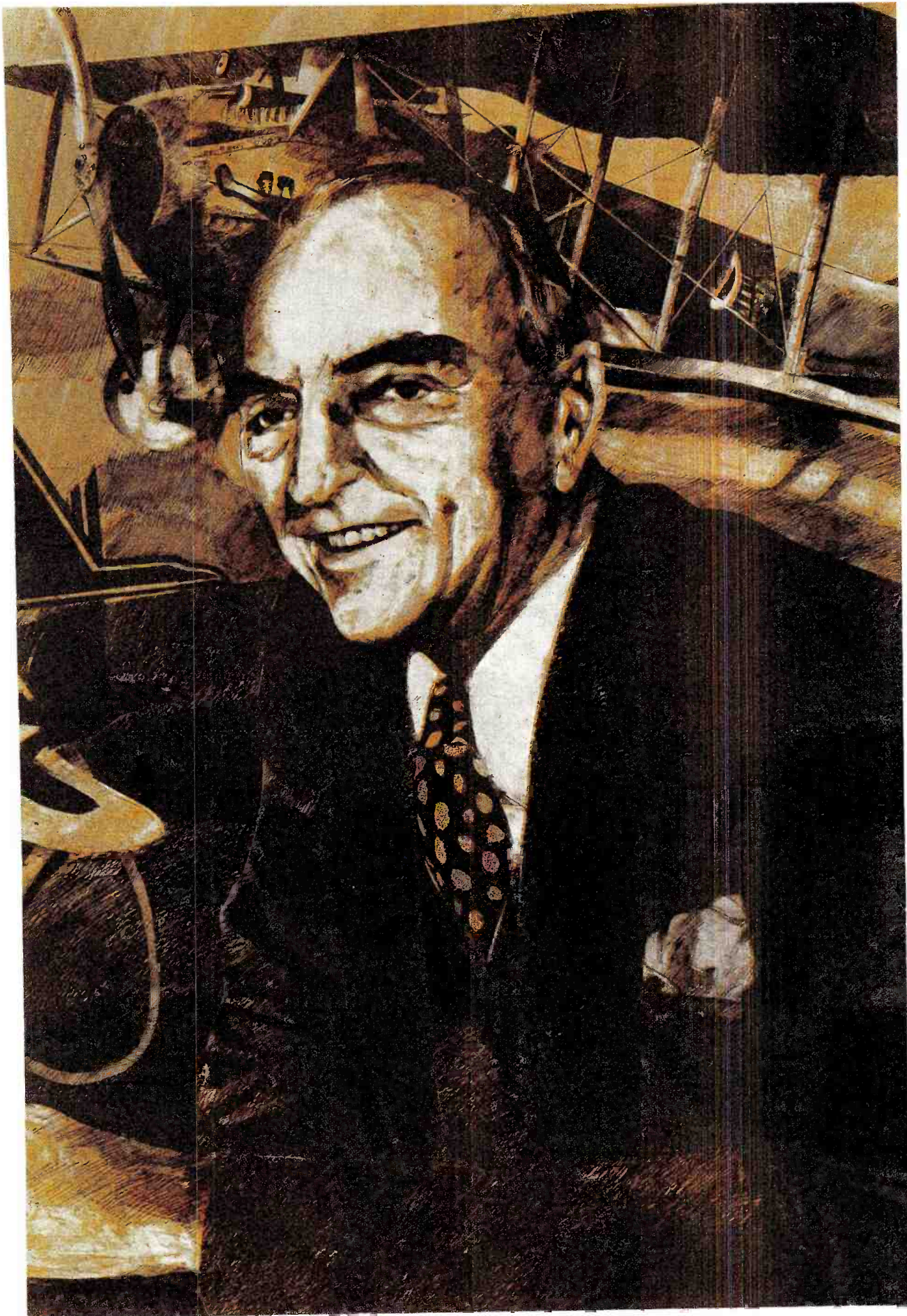



View from the Lion's Den

War is Hell, Lieutenant

■ While war is history, real (and a profession) it fortunately doesn't have universal appeal. It is certainly a subject women shun. A recent example is found in television. This past season brought two war slanted series to home screens. Their action and adventure was popular with men, *but was of great disinterest to women*. TvQ found both shows were over 40% more popular with men than women. This is not the ratio for top TV success. By contrast, the reverse ratio is true of drama programs. So, can we have the best of two worlds? Something military and dramatic for both men and women?

■ The answer is the peacetime Marines. There's no argument (and there better not be) that the Marine Corps is a fighting outfit. But, what is it like to learn the difficult profession of a Marine? A young marine has many of the learning problems of the young doctor or lawyer—yet he's assigned responsibilities quicker, has tougher ground rules. For any bright, dedicated and sensitive young man, learning the job of Marine is loaded with drama potential.

■ *Sound off.* Right now all these elements of drama centered around a young lieutenant in the peacetime Marine Corps are being put on film—an hour's worth a week for a September start on NBC-TV 7:30 pm Saturdays. There's all the action of land, sea and air training for the old "boot" or the contemporary youngsters. Plus there's the dramatic, occasionally traumatic, transformation of a young officer from a "green shavetail" to a combat-ready platoon leader. Here is real flesh and blood excitement of living and learning—on base and off.

■ This series is called *THE LIEUTENANT*. It stars, to quote an accurate press release, "rugged ex-football player and film stuntman" Gary Lockwood, with Robert Vaughn as co-star. Already Lockwood has learned much of what it's like to be a Marine. The Marines are trying to learn from him what it's like to be a TV star; such things as "What kind of a date is Tuesday Weld?" Peace, it's wonderful.

DATEBOOK

A calendar of important meetings and events in the field of communications

*Indicates first or revised listing

AUGUST

Aug. 5—Effective date for new Emergency Broadcast System, which will eventually allow all radio stations to stay on air during war alert (BROADCASTING, July 8).

Aug. 11-15—Second annual NCTA Management Institute, sponsored by National Community Television Association in cooperation with the extension division of University of Wisconsin, Madison.

Aug. 14—Second annual TV Day, Georgia Association of Broadcasters, Macon.

Aug. 14—Communications committee meet of the American Bar Association, Conrad Hilton hotel, Chicago. Speaker will be FCC Chairman E. William Henry.

Aug. 19—Eighth annual Distributor-Manufacturer-Representative conference, Jack Tar hotel, San Francisco. Chairman of the conference planners is Elvin W. Feige, president of Elmar Electronics of Oakland.

*Aug. 20—Annual stockholders meeting, Desilu Productions Inc., Hollywood.

Aug. 20-23—Western Electric Show and Convention (WESCON), San Francisco's Cow Palace. Papers include: "Telstar" by Irwin Welber of Bell Telephone Laboratories; "Relay" by Warren Schreiner of RCA; "Syncom" by Dr. Harold A. Rosen of Hughes Aircraft Co.; "Comsat" by Wilbur L. Pritchard of Aerospace Corp.; "Commercial Communications Satellites" by Beardsley Graham of Spindletop Research.

Aug. 23-24—Oklahoma Broadcasters Association convention, Western Hills State Lodge, Wagoner. Speakers include Oklahoma Governor Henry Bellmon, Ed Bunker, president of Radio Advertising Bureau, and Robert Richardson, special counsel to the House Subcommittee on Investigations.

Aug. 26-27—Television Affiliates Corp. West Coast programing conference, Hilton Inn, San Francisco.

Aug. 27—Board of Broadcast Governors hearing, Ottawa, Canada.

SEPTEMBER

*Sept. 1—Deadline for comments on FAA proposed criteria for establishment of television antenna farms.

Sept. 5-8—Annual fall meeting of West Virginia Broadcasters Association, The Greenbrier, White Sulphur Springs.

Sept. 6-7—Fall meeting of Arkansas Broadcasters Association, Holiday Inn, North Little Rock. LeRoy Collins, NAB president, will be principal speaker.

Sept. 6-7—Arkansas AP Broadcasters Association. Principal speaker is AP Assistant General Manager Louis J. Kramp.

Sept. 7—American Women in Radio and Television's Educational Foundation board of trustees meeting, New York City.

Sept. 8-11—Western Association of Broadcasters annual meeting, Jasper Park Lodge, Jasper, Alberta, Canada.

*Sept. 9—Effective date of new instructional television service using 31 channels in 2500-2690 mc band.

Sept. 9-12—New York Premium Show, New York Coliseum.

Sept. 10—Premium advertising conference of the Premium Advertising Association of America, New York Coliseum.

Sept. 10-12—Fall meeting of Electronic Industries Association, Biltmore hotel, New York City.

Sept. 11-14—Eighteenth international conference and workshop of Radio-Television

News Directors Association, Radisson hotel, Minneapolis.

Sept. 12—Luncheon meeting, Federal Communications Bar Association, FCC Commissioner Lee Loewinger, speaker. National Press Club, Washington.

Sept. 12-15—Annual fall convention, Michigan Association of Broadcasters, Hidden Valley, Gaylord, Mich.

Sept. 13-22—International Radio, Television & Electronics Exhibition (FIRATO) at the R.A.I. Building in Amsterdam. Live TV programs will be broadcast from a special studio to be set up at the show. This will be carried out by the Netherlands Television Foundation in cooperation with Dutch television channels.

Sept. 14-15—Southwest Regional Conference, American Women in Radio and Television, Houston.

Sept. 15-16—New York State AP Broadcasters Association, Gran-View motel, Ogdensburg. Don Jamieson, president of the Canadian Association of Broadcasters, will be the speaker at the Sunday evening banquet. Sunday afternoon and Monday morning will be taken up with business sessions, followed by a tour of the St. Lawrence Seaway aboard a United States Coast Guard vessel.

Sept. 15-17—Louisiana Association of Broadcasters convention, Sheraton Charles hotel, New Orleans.

Sept. 16—New deadline for comments on FCC's proposal to control the development of AM and FM radio services.

Sept. 17—Annual stockholders meeting, Rollins Broadcasting Co., Bank of Delaware Building, Wilmington, Del.

Sept. 17-19—American Association of Advertising Agencies' western region meeting. Mark Hopkins hotel, San Francisco.

Sept. 20-22—American Women in Radio and Television southern area conference, Columbus, Ga.

Sept. 23-25—Nevada Broadcasters Association first annual convention, Hotel Sahara, Las Vegas.

Sept. 26-27—Association of National Advertisers' workshop on advertising planning and administration, Nassau Inn, Princeton.

Sept. 30-Oct. 1—Seventeenth annual convention of the New Jersey Broadcasters Association, Colony motel, Atlantic City, N. J.

Sept. 30-Oct. 4—Georgia Association of Broadcasters' regional meetings (Athens, Rome, Thomaston, Albany, Statesboro) featuring sales clinic with Fred A. Palmer.

OCTOBER

Oct. 1—Advertising Research Foundation's conference, Hotel Commodore, New York.

Oct. 4-6—American Women in Radio and

NAB CONFERENCE DATES

National Association of Broadcasters fall conference dates:

Oct. 14-15, Statler-Hilton hotel, Hartford, Conn.

Oct. 17-18, Leamington hotel, Minneapolis.

Oct. 21-22, Pittsburgh Hilton hotel, Pittsburgh.

Oct. 24-25, Americana hotel, Miami Beach.

Nov. 14-15, Dinkler-Andrew Jackson hotel, Nashville.

Nov. 18-19, Texas hotel, Fort Worth.

Nov. 21-22, Denver Hilton hotel, Denver.

Nov. 25-26, Fairmont hotel, San Francisco.

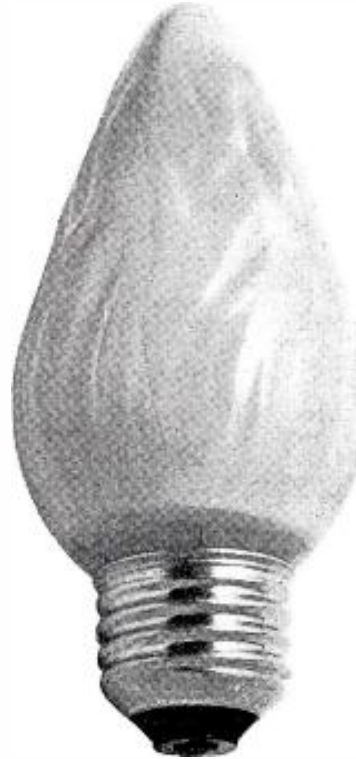

**CAN YOU THINK OF A BETTER WAY
TO SELL CHRISTMAS TREE LIGHTS
AT \$100 EACH?**

Every year WTMJ-TV promotes a fund-raising campaign in Milwaukee on behalf of the Salvation Army's Christmas Cheer program. For each \$100 contributed, a bulb is lighted on a giant Christmas tree in downtown Milwaukee. Last holiday season, Milwaukeeans set the tree aglow with close to \$45,000. This response is typical of the influence WTMJ-TV has on Milwaukee . . . one of the top ten metropolitan areas in many measures of sales per household. See for yourself. Put your sales message on WTMJ-TV . . . still the number one station in Milwaukee for both viewers and advertisers.

**MILWAUKEE RESPONDS TO WTMJ-TV
CHANNEL 4**

THE MILWAUKEE JOURNAL STATION
WTMJ-AM-FM
NBC in Milwaukee

Represented by: HARRINGTON, RIGHTER & PARSONS — New York
Chicago • San Francisco • Atlanta • Boston • St. Louis • Los Angeles

HEARD IT ON THAT
NEW RADIO STATION



WVON
1450 on your radio

- ... All Negro air personalities
- ... Strong Hooper ratings
- ... Merchandising plan that creates sales

1.2 Million Negroes in
Chicagoland

Represented by **Bob Dore Associates** or **Lloyd Webb**
312-847-2600



Automation

Has it helped others? Can it help you? How many approaches to automation are available?

What can IGM offer you? Equipment, straight music, announced programming, custom programming, and over 4 years of experience in production and use of automation! Write for our brochure, "THE WHY AND HOW OF AUTOMATION."

IGM Simplimation

Main Office and Plant
P.O. Box 943
Bellingham, Wash.
733-4567 (Area 206)

In New York City
TELE-MEASUREMENTS, Inc.
45 W. 45th St.
581-9020 (Area 212)

Television east-central area conference, Coach House Inn, Milwaukee.

Oct. 4-6—American Women in Radio and Television New England conference, Chat-ham Bars Inn, Cape Cod, Mass.

*Oct. 8-10—International Film Festival, Barbizon Plaza hotel, New York.

Oct. 11-13—American Women in Radio and Television west-central area conference, Holiday Inn South, Des Moines, Iowa.

Oct. 13-18—Second Advanced Advertising Management Course of the Association of National Advertisers, Hotel Moraine-on-the-Lake, Highland Park, Ill. R. P. Campbell, advertising manager for Post division of General Foods Corp., heads the subcommittee which is planning this course.

Oct. 14-18—Ninety-fourth convention of the Society of Motion Picture and Television Engineers, Somerset hotel, Boston.

Oct. 14-18—Fifteenth annual fall convention of Audio Engineering Society, Barbizon Plaza hotel, New York.

Oct. 16—Deadline for reply comments on FCC's rulemaking to control the development of AM and FM radio services.

Oct. 17-18—American Association of Advertising Agencies (AAAA) central region meeting, Sheraton hotel, Chicago.

Oct. 18—Indiana Associated Press Radio-TV Association, French Lick.

Oct. 20-21—Meeting of Texas Association of Broadcasters, Cabana hotel, Dallas.

Oct. 24—Fourth Armed Forces Television Conference, sponsored by U. S. Air Force, Lowry Air Force Base, Denver, Colo. The conference will deal primarily with educational and technical uses of television by the military services. A trip to the Air Force Academy's closed-circuit television installation is also planned.

Oct. 25-27—American Women in Radio and Television board of directors meeting, Mayo hotel, Tulsa, Okla.

Oct. 28-30—National Electronics Conference, McCormick Place, Chicago.

Oct. 28-30—Third annual meeting, Institute of Broadcasting Financial Management, New York Hilton at Rockefeller Center.

Oct. 31-Nov. 1—Electron Devices Meeting of the Institute of Electrical and Electronics Engineers, Sheraton Park hotel, Washington, D. C. Speakers include John Hornbeck, formerly of Bell Telephone Labs and now president of Bellcom Inc., "Electron Devices for Space Applications"; Victor H. Grinich, Fairchild Semiconductors, "Why Field Effect Transistors?" and Lester F. Eastman, Cornell University, "Super Power Microwave Tubes." Program chairman for the meeting is Mason A. Clark, Hewlett-Packard Associates, Palo Alto, Calif.

NOVEMBER

Nov. 1-2—Oregon Association of Broadcasters convention, Hilton hotel, Portland.

Nov. 1-2—Grand Ole Opry 38th anniversary celebration, Nashville. Agenda includes expanded seminar of sales and programing.

Nov. 4-5—Central Canadian Broadcasters Association management and engineering convention, Royal York hotel, Toronto.

Nov. 6-7—American Association of Advertising Agencies (AAAA) eastern annual meeting, Waldorf-Astoria, New York.

*Nov. 6-9—National convention of Sigma Delta Chi, professional journalistic society, Golden Triangle Motel, Norfolk, Va. Dr. Glenn T. Seaborg, chairman of the Atomic Energy Commission, will be featured speaker at the Nov. 7 luncheon.

Nov. 10-12—ACRTF Convention, Quebec City, Canada.

Nov. 10-13—Annual meeting of the Association of National Advertisers, The Homestead, Hot Springs, Va.

Nov. 17-20—National Association of Educational Broadcasters national convention, Hotel Schroeder, Milwaukee, Wis. Banquet speaker is FCC Chairman E. William Henry.

RAB MANAGEMENT CONFERENCES

Sept. 9-10—The Homestead, Hot Springs, Va.; Sept. 12-13, The Hilton Inn, airport, Atlanta.

Sept. 16-17—The Holiday Inn-Central, Dallas.

Sept. 23-24—Gideon-Putnam, Saratoga Springs, N. Y.

Sept. 30-Oct. 1—O'Hare Inn, airport, Chicago; Oct. 3-4, Rickey's Hyatt House hotel, Palo Alto, Calif.; Oct. 7-8, Town House Motor hotel, Omaha.

Oct. 14-15—The Executive Inn, Detroit, Mich.

Nov. 17-20—Broadcasters Promotion Association annual convention, Jack Tar hotel, San Francisco. Joseph P. Constantino, KTVU (TV) Oakland-San Francisco, is convention general chairman.

Nov. 20—American Association of Advertising Agencies (AAAA) east-central region meeting, Statler Hilton, Cleveland.

Nov. 22—National Academy of Television Arts and Sciences, New York chapter, holds "Close-Up" dinner and show lampooning comedian Jackie Gleason. Hilton hotel, New York.

Nov. 22-23—Combined meeting of Wisconsin Associated Press newspaper and broadcasting members, Milwaukee.

DECEMBER

Dec. 3-5—Winter conference of Electronic Industries Association, Statler-Hilton hotel, Los Angeles.

Dec. 5-6—Fourteenth conference of the Professional Technical Group on Vehicular Communications, Adolphus hotel, Dallas.

*Dec. 6—Association of National Advertisers' workshop on planning and evaluation, The Plaza, New York City.

JANUARY 1964

Jan. 21-23—National Religious Broadcasters convention, Mayflower hotel, Washington.

*Jan. 21-23—Nineteenth annual Georgia Radio-TV Institute, co-sponsored by the Georgia Association of Broadcasters and the Henry Grady School of Journalism, University of Georgia, Athens.

*Jan. 24-26—Mid-winter convention of the Advertising Association of the West, Bakersfield, Calif.

*Jan. 24-26—American Women in Radio and Television board of directors meeting, New York Hilton hotel.

FEBRUARY

*Feb. 5-7—National Winter Convention on Military Electronics, Ambassador hotel, Los Angeles. C. D. Perrine, executive vice president of General Dynamics/Pomona, is convention chairman.

*Feb. 26-28—Ninth Scintillation and Semiconductor Counter Symposium, under the sponsorship of the Institute of Electrical and Electronics Engineers, the Atomic Energy Commission, and the National Bureau of Standards, Hotel Shoreham, Washington, D. C. Program committee chairman is W. A. Higinbotham, Brookhaven National Laboratory, Upton, L. I., N. Y. The deadline for abstracts is Dec. 1.

APRIL

*April 5-8—Annual convention of the National Association of Broadcasters, Conrad Hilton hotel, Chicago.

*April 30-May 3—Thirteenth annual convention of the American Women in Radio and Television, Mayo hotel, Tulsa, Okla.

JUNE

*June 13-16—Summer convention of the Georgia Association of Broadcasters, Cal-laway Gardens, Ga.



the triumphs . . .



the tragedies . . .



the truth

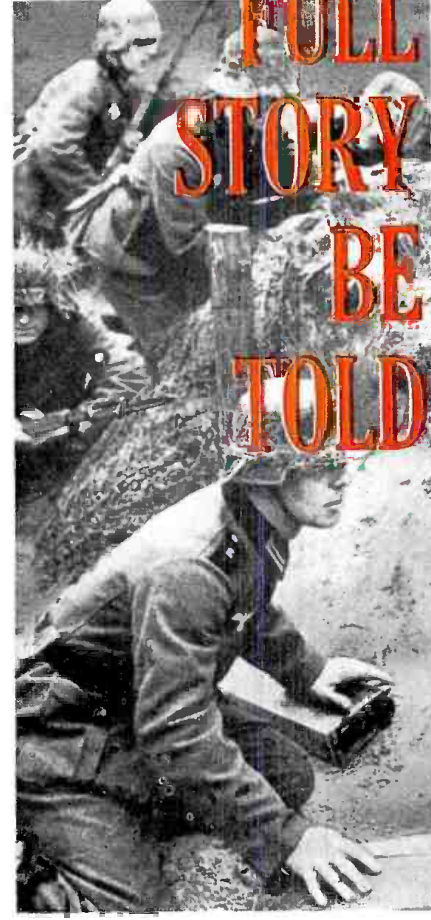

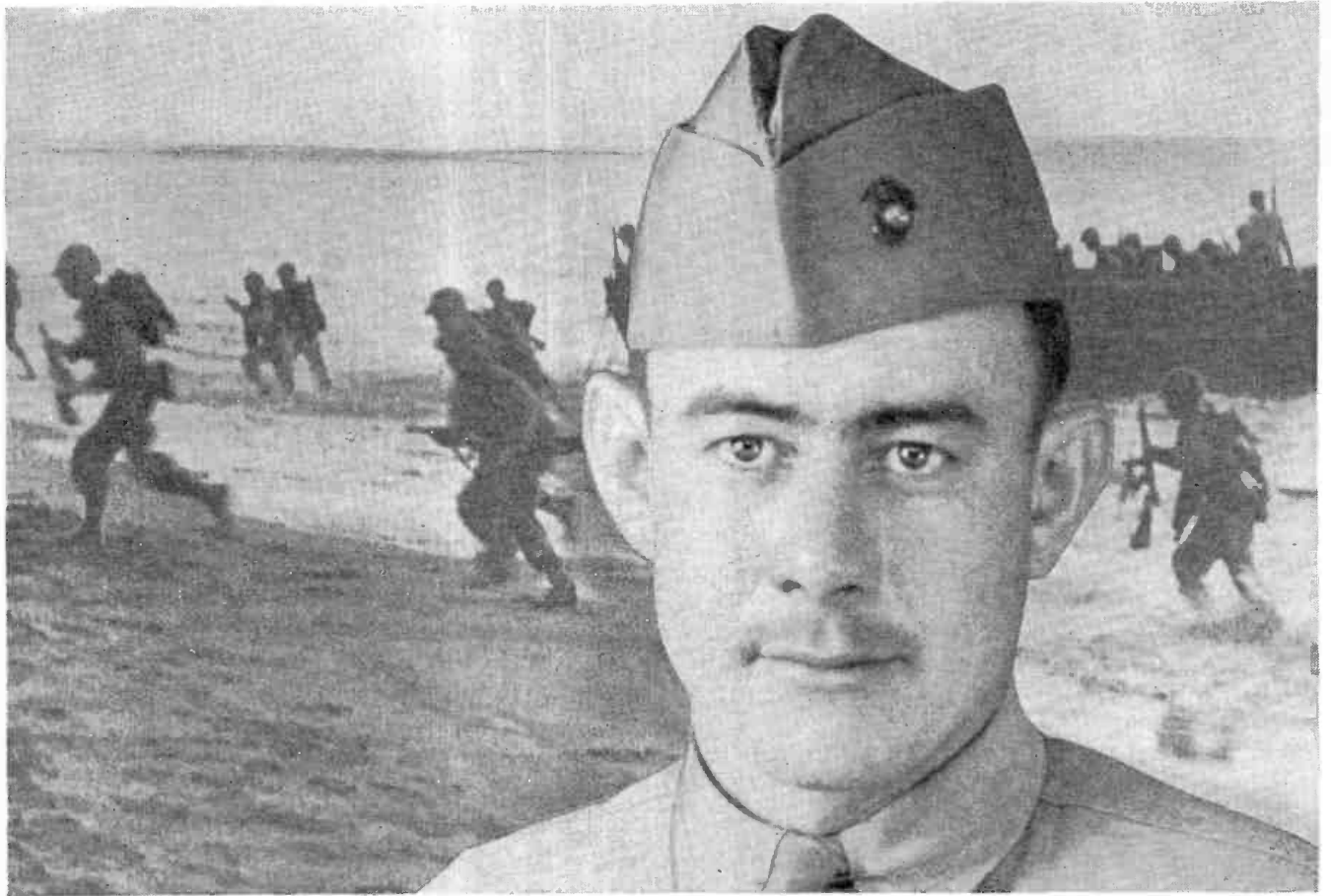

of World War II as seen through the eyes of the fighting m



Here at last is the story of World War II told by the men who were there . . . on both sides of the Battle Line. This is no "General's War," no reporter's story, no "official document." It's War in the words of the men who fought it, now retold for the first time. Years of painstaking research went into finding surviving combatants of World War II's most important campaigns — Pearl Harbor, the Bismarck, the Kamikaze and U Boat raids, Salerno, Iwo Jima, Stalingrad. Now, these men — Allied and Axis — come before the cameras and tell how these never-to-be-forgotten events looked through their eyes. This is war, in all its raw truth, stripped of its gloss and glamour. And backing their words is the world's finest war film footage, much of it until now, locked behind the Iron and Bamboo Curtains. This is war as it actually was, seen by the men who were there, on both sides of the —

on both sides of the

BATTLE LINE

The title 'BATTLE LINE' is rendered in a bold, red, sans-serif font. The word 'BATTLE' is positioned above 'LINE'. The letters are filled with a horizontal line pattern. A graphic of barbed wire is superimposed over the text, with a dagger or spearhead pointing upwards through the center of the word 'LINE'.

Narrating each episode is Jim Bishop, popular historian and author of "The Day Lincoln Was Shot" and "The Day Christ Died." During World War II Jim Bishop, as War Editor of *Colliers*, had access to the key stories of the day. Yet because of official secrecy and wartime censorship, much of this vital information could not be transmitted to the public. Now at last this popular correspondent can reveal information that tells of some of the early staggering defeats that all but destroyed the Allied and American Armed Forces . . . information that puts in its full perspective the courage and determination of the fighting men who ultimately won victory. Jim Bishop, with his first hand knowledge, historic perspective and insight of the human spirit weaves this unprecedented series with the exactly right blend of compassion and understanding.

The 1960's: the decade of the bold, forward-looking marketer

Of the presidents of the top 58 companies in the country today, 21—or better than one out of three—advanced to their jobs through advertising, marketing or sales. These are 10 more than those who got there through the financial route and 11 more than those who came up through research or engineering.

That's a statistic based on the past. The odds are even better for the future.

Remember the 1920's? Whose star shone brightest in that roaring time between war and depression? The ones who made mass production a reality—the Henry Fords, who found a better way to make it for less.

Now recall the 30's—the decade of the legal or financial man.

And let's take a look at the 40's—the era of the ingenious substituter, when even the lowly penny gave up its copper.

By the 1950's a new kind of executive was rising to power. He was the distribution genius—the retailer with a new concept who asked "What does the public need and want to buy that we can make or have made—and how do they want to buy it?" And so the early pioneers in supermarkets and discount houses were joined by the automatic vending machine and the many coin-operated services.

The Present ■ What about the 60's? This decade needs every smart marketing man, advertising man and salesman it can get. Without them this bright decade is going to look pretty tarnished.

Henry Ford's secret of mass production is now everybody's. There isn't a company anywhere that can't increase production by 50% any time it wants to. The problem has an almost mathematical solution. The vice president in charge of production can tell the board of directors, "we can increase production in X weeks at a cost of Y cents per unit, to be amortized after the first Z additional units are made."

Can you envision a marketing man making this absolute a promise? How much will it cost to increase sales by 50%. How long will it take? Is there a quicker way? How much extra cost?

Are there any answers? Not as precise as the production man's, certainly. And because we are talking about human beings and their moods, likes and dislikes, and not machines, there never will be any precise answers.

Just because it can't be worked out on a computer is no reason to relax. We can keep trying to make the answers more precise.

Be Original ■ But, you're thinking, how can I make the presidency by okaying a set of proofs? A fair question, and the answer is short and direct—you can't. You're going to make it not by okaying something that's been done, but by creating something that hasn't been done.

Take the concept that the end result of advertising is good earnings. This leads inevitably to the sister concept that advertising per se is only one of many forms of marketing communications. This in turn leads to another notion—the idea that a marketing dollar should be viewed as a whole, with so many cents going to advertising, so much more to sales promotion, to publicity, to sales and dealer communications, to research, and so on.

Such a concept led us at McCann-Erickson Inc. some years ago to look at these separate forms of communications to and from various publics and view them as completely related parts of the whole. And it was inevitable to conclude that if all these forms of marketing communications were managed and directed at a common target, the marketing communications dollar would bring the greatest dollar return.

As a result, a little over two years ago a unique marketing communications company was born, designed to provide professional services in each of these areas—and designed to relate them to each other in such a way that they could and did aim at a single goal.

Working Concept ■ Under our parent company, Interpublic Inc., this concept is still growing and expanding today.

Interpublic today owns several advertising agencies. Interpublic also owns Communications Affiliations Inc., which operates Marplan, a worldwide research organization; Infoplan, a worldwide public relations and publicity organization, and SCI, a sales communications organization.

On the corporate level, Interpublic provides personnel, financial, legal, business development and advance project services to all its components.

Some months ago, a division of McCann-Erickson called Industrial Technical Scientific Marketing was established. Why? Because communicating with a technical or scientific audience today is a highly specialized job, and needs specialists to do it.

Knowledge In Motion ■ We are in an information revolution. Our knowledge now doubles every year. Of all scientists who ever lived, 90% are still living. A graduate from a scientific or engineering school this year will, unless he continues his studies indefinitely in his free time, find himself technically left behind in only seven years.

The fact that this concept is in motion and moving fast can best be grasped by looking at what happened and is happening. In 1951 McCann-Erickson Inc. was an \$81 million business. At the end of 1962 Interpublic was doing well over \$400 million from 89 offices in 26 countries. In the first months of 1963, six new offices and two more countries were added, and further additions are to be expected. This, I feel, is conclusive evidence that there is a tremendous worldwide need for just such an integrated marketing communications facility—and strong validation of the concept that brought it into being.

The advertising business that we have known so long is not the same today, and never will be the same again. Today, serious minded investors consider a company's marketing goals and advertising expenditures one of the significant indicators of its future earnings. The concept of spending money to make money has the active approval of the financial community. These changes are important and vital.

The 1960's are definitely the decade of the bold, forward-looking marketer.



Henry A. Mattoon has been vice president and general manager of McCann-Erickson's Los Angeles office since July 1962. Mr. Mattoon joined McCann-Erickson in 1956 as a vice president in the New York office and served over the next six years as chairman of the agency's marketing plans board as an associate creative director. Before his affiliation with McCann-Erickson, Mr. Mattoon served as president and a director of Reach, Yates & Mattoon, New York and Newark.

MAXIMUM RESPONSE
—that's advertising efficiency.



WBAL-TV BALTIMORE

"MARYLAND'S NUMBER ONE CHANNEL OF COMMUNICATION"

NATIONALLY REPRESENTED BY EDWARD PETRY & CO., INC.

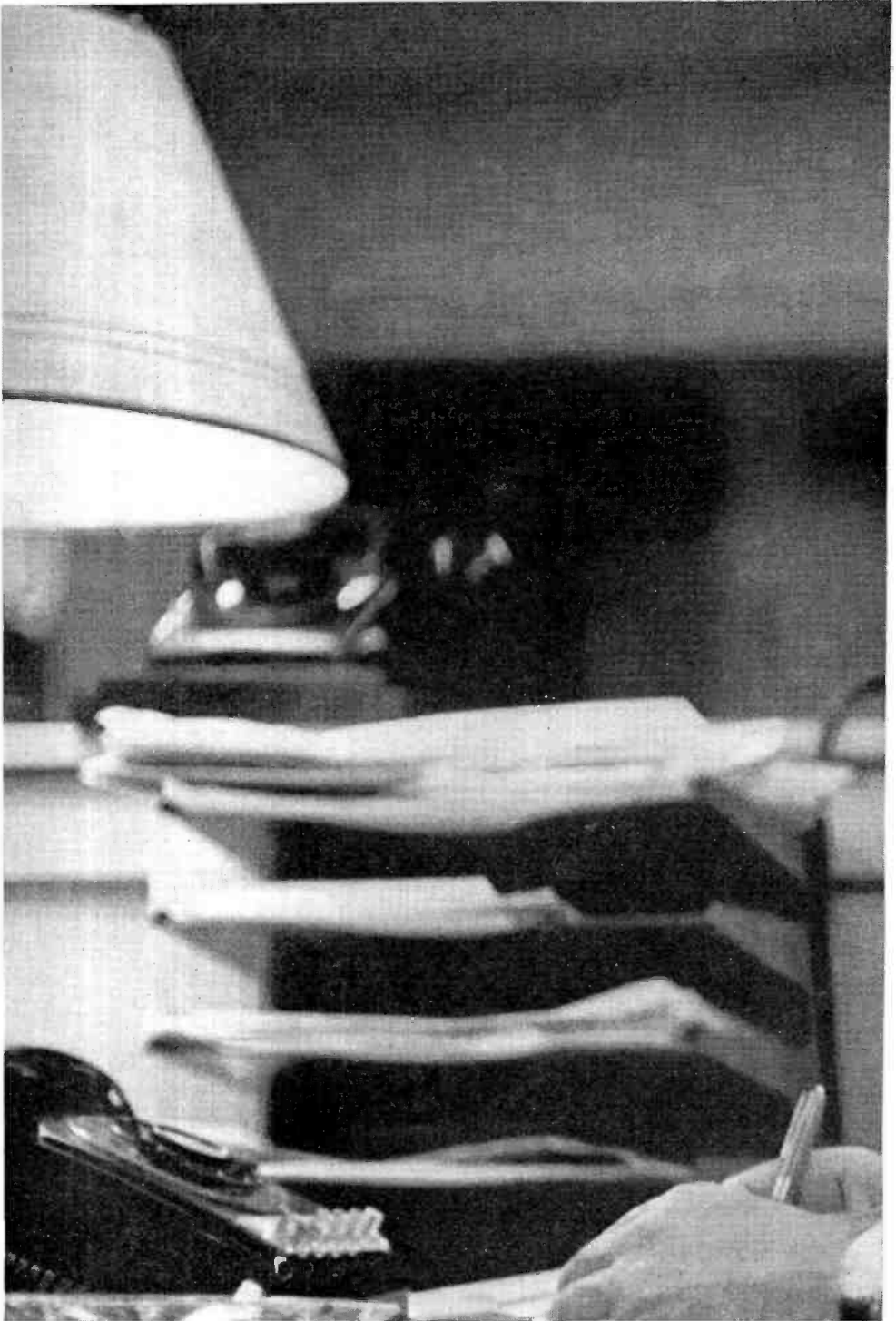

Sunday's Driver

Although he's already featured regularly on the "Today" show and NBC Radio's "Monitor," Frank Blair (above) has unhesitatingly accepted still another assignment: host of the forthcoming "Sunday" series.

Fact is, it will be a labor of love for Blair to be in the "Sunday" driver's seat, since the program will cover a range of interests as wide as his own.

When it becomes a Sunday afternoon highlight

of the formidable NBC Fall schedule, the live, full-hour series will not only cover leading national and international happenings, but—like a weekend newspaper magazine—span Music, Art, Science, Theatre, Books and Sports.

In keeping with this concept, a corps of reporters will appear each week, including NBC Washington correspondents Ray Scherer, Robert Abernethy and Nancy Dickerson, and sportscaster-humorist Joe Garagiola.

SUNDAY



Analyses of the passing scene will be offered regularly by NBC's witty, literate Edwin Newman and frequent visitors such as Cleveland Amory, columnist, author and perceptive chronicler of American society; and Aline Saarinen, one of the art world's most authoritative critics.

"Sunday's" very able back-seat driver is producer Robert Northshield, whose past credits include "Today" and such acclaimed NBC News specials as "The Chosen Child," "Who Goes

There?," and "The Trial of Adolf Eichmann."

Of course, "Sunday's" diversity merely reflects the span of our *entire* Fall schedule, which ranges from the urbane "Tonight" to the newest adventure series, "Temple Houston"; from the world-news coverage of the expanded "Huntley-Brinkley Report" to the music of the Andy Williams specials. In all, it shapes up as a season whose virtues couldn't really be described in a month of "Sundays."



Look to NBC for the best combination of news, information and entertainment.

OPEN MIKE @



"Jethro, what in heck's a Ark-La-Tex?"

Jethro: "Ark-La-Tex is where over 342,000 folks watch us on the TV."

(Let us take it from there)

Ark-La-Tex is a rich chunk of three states . . . nation's 68th TV market . . . lots of oil and gas . . . manufacturing . . . rich cotton farms . . . major military installations . . . distribution center . . . a diversified economy. Folks here live it up . . . and love it! Call your Harrington, Righter and Parsons representative for prime time minutes and choice local news participations.

KSLA-TV

tenth year of leadership
SHREVEPORT

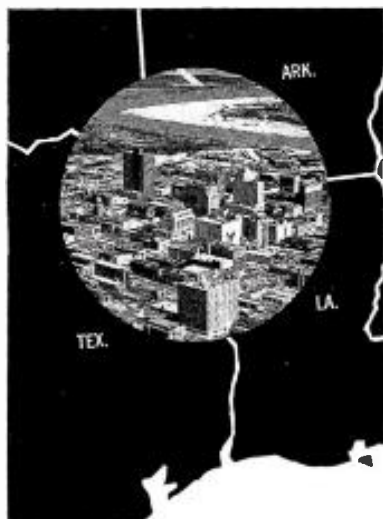

*ARB Mar. 1963 and Television Mag.

Comprehensive story

EDITOR: Your special article on the new DCSS media marketing concept was a most comprehensive piece of reporting (BROADCASTING, June 24). Reaction to the story has been very favorable, and on behalf of our agency, I want to thank you sincerely for your fine efforts. —*John R. Rockwell, executive vice president, Doherty, Clifford, Steers & Shenfield Inc., New York.*

A dedicated pioneer

EDITOR: I am delighted with your "respects" to Peggy Stone (BROADCASTING, July 22). It recognizes one of the dedicated pioneers of our great industry. She has not only raised a family and a business successfully, she has contributed importantly to the growth of the International Radio and Television Society and the Broadcast Pioneers. With hundreds of others, I am happy to be her friend.—*Tom McDermott, vice president, N. W. Ayer & Son Inc., New York.*

Tallest towers, continued

EDITOR: It will probably be of interest that our concern now has orders for three towers, all of which are taller than the present tallest existing man-made structure in the world (1,749 feet). One is 1,800 feet designed for an addition of 200 feet at a later date, one is 2,000 feet and one is 2,063 feet. The tallest of these three is approximately half again taller than the Empire State Building (1,472 feet).—*B. H. Kline, Kline Iron & Steel Co., Columbia, S. C.*

Change through education

EDITOR: The June 8 resolution of the National Council of Churches calling for firm government clamps on radio and TV is certainly the talk of our industry (BROADCASTING, June 17). Before broadcasters rush off in all directions to fight the ivory-tower leftists who supported the resolution, let us take note of the thousands of well-grounded, intelligent and sound clergymen who know what goes on in radio and TV and how responsive it is to their ideas and suggestions. The resolution pales when we consider the powerful radio and TV programming produced by such groups as the Lutheran Laymen's League, the American Lutheran Church, Southern Baptist's Convention and the Christophers. Churchmen of these groups are right in the thick of the fight to inform and uplift Americans, shoulder to shoulder with responsible broadcasters anxious to do all they can to make this a better

BROADCASTING PUBLICATIONS INC.

PRESIDENT . . . SOL TAISHOFF
VICE PRESIDENT . . . MAURY LONG
VICE PRESIDENT . . . EDWIN H. JAMES
SECRETARY . . . H. H. TASH
TREASURER . . . B. T. TAISHOFF
COMPTROLLER . . . IRVING C. MILLER
ASST. SEC.-TREAS. . . LAWRENCE B. TAISHOFF

BROADCASTING

THE BUSINESSWEEKLY OF TELEVISION AND RADIO
Executive and publication headquarters:
BROADCASTING-TELECASTING Bldg., 1735 DeSales
Street, N.W., Washington, D. C. ZIP code
20036. Telephone: 202 Metropolitan 8-1022.

EDITOR AND PUBLISHER
Sol Taishoff

Editorial

VICE PRESIDENT AND EXECUTIVE EDITOR
Edwin H. James

EDITORIAL DIRECTOR (New York)
Rufus Crater

MANAGING EDITOR
Art King

SENIOR EDITORS: J. Frank Beatty, Bruce Robertson (Hollywood), Frederick M. Fitzgerald, Earl B. Abrams, Lawrence Christopher (Chicago), Dawson Nail; ASSOCIATE EDITORS: George Darlington, Leonard Zeidenberg; STAFF WRITERS: Sid Booth, Sherm Brodey, Gary Campbell, Jim deBettencourt, Larry Michie; EDITORIAL ASSISTANTS: Natalie D. Lucenko, Taniil Oman, Judi Sue Robin, Chuck Shaffer; SECRETARY TO THE PUBLISHER: Gladys Hall.

Business

VICE PRESIDENT AND GENERAL MANAGER
Maury Long

VICE PRESIDENT AND SALES MANAGER
Winfield R. Levi (New York)

ASSISTANT PUBLISHER
Lawrence B. Taishoff

SOUTHERN SALES MANAGER: Ed Sellers; PRODUCTION MANAGER: George L. Dant; TRAFFIC MANAGER: Harry Stevens; ADVERTISING ASSISTANTS: Robert Sandor, Carol Ann Jenkins, Ken Albright; SECRETARY TO THE GENERAL MANAGER: Doris Kelly.

COMPTROLLER: Irving C. Miller; ASSISTANT AUDITOR: Eunice Weston.

Publications and Circulation

DIRECTOR OF PUBLICATIONS
John P. Cosgrove

CIRCULATION MANAGER: Frank N. Gentile; CIRCULATION ASSISTANTS: Edith Liu, Dave Lambert, Germain Rojas, Joan Chang, Bruce Kennedy, Marc Beaulieu.

Bureaus

New York: 444 Madison Avenue, ZIP code 10022. Telephone: 212 Plaza 5-8354.

EDITORIAL DIRECTOR: Rufus Crater; BUREAU NEWS MANAGER: David W. Berlyn; ASSOCIATE EDITOR: Rocco Famighetti; STAFF WRITERS: John Gardiner, Phil Grose, Larry Littman, Ellen R. McCormick. ASSISTANT: Frances Bonovitch.

VICE PRESIDENT AND SALES MANAGER: Winfield R. Levi; EASTERN SALES MANAGER: Don Kuyk; INSTITUTIONAL SALES MANAGER: Eleanor R. Manning; ADVERTISING ASSISTANT: Beryl W. Stern.

Chicago: 360 North Michigan Avenue, ZIP code 60601. Telephone 312 Central 6-4115.

SENIOR EDITOR: Lawrence Christopher; MIDWEST SALES MANAGER: Warren W. Middleton; ASSISTANT: Rose Adragna.

Hollywood: 1680 North Vine Street, ZIP code 90028. Telephone: 213 Hollywood 3-3148.

SENIOR EDITOR: Bruce Robertson; WESTERN SALES MANAGER: Bill Merritt; ASSISTANT: Gail Leatman.

Toronto: 11 Burton Road, Zone 10. Telephone: 416 Hudson 9-2694. CORRESPONDENT: James Montagnes.

BROADCASTING* Magazine was founded in 1931 by Broadcasting Publications Inc. using the title, BROADCASTING*—The News Magazine of the Fifth Estate. Broadcast Advertising* was acquired in 1932. Broadcast Reporter in 1933 and Telecast* in 1953. BROADCASTING-TELECASTING* was introduced in 1946.

*Reg. U. S. Patent Office

Copyright 1963: Broadcasting Publications Inc.

BROADCASTING, August 5, 1963



MEDIA DEPT.

(Thanks and \$100 to B. S., Indianapolis)

FALSE?

Things are not always exactly what they appear to be. Example: Nashville APPEARS to be a small southern city of slightly over 400,000. But reach a little further and you'll discover that the Nashville television market numbers 2,052,300 people and some 450,000 television homes. 98% of these homes depend on Nashville for network TV. 96% of them look to Nashville for ALL TV. So, while Nashville LOOKS like America's 65th city, it's actually the Nation's 28th television market.* Aren't these points worth further investigation?

*ARB, March 1962, 9:00 A.M. to 12:00 Midnight

WSIX-TV
ABC-TV Channel 8

WLAC-TV
CBS-TV Channel 5

WSM-TV
NBC-TV Channel 4

NASHVILLE, TENNESSEE

WIBC The Friendly Voice of Indiana

Aim—Editorials with impact!



LEADS IN ACCEPTANCE

WIBC editorial #313 came about as had many others. A problem had been found which we related to our listeners and offered a possible solution. Specifically, the Indiana World War Memorial Plaza had been permitted to fall into a state of disrepair. This condition existed because maintenance funds had not been provided by the General Assembly.

Following the editorial Jack D. Trowbridge, the Memorial Commission's secretary, announced that Explorer Scout Troop #60 had volunteered to launch the project by cleaning the many rows of hedge in the two-block long plaza. On Saturday, July 13, sixteen members of the troop did just that. In spite of intermittent showers, they worked hard and made a tremendous improvement in the appearance of the area.

LEADS IN AUDIENCE

While this is not a permanent solution, it indicates that the youth of Indianapolis are vitally interested in community problems. We're glad to number young men like these in the huge audience of WIBC . . . the only station that delivers both Indianapolis and Indiana!

2835 N. Illinois Street
Indianapolis 8, Indiana

50,000 WATTS **WIBC** 1070 KC

The Friendly Voice of Indiana

JOHN BLAIR & COMPANY
National Representative



WIBC IS A MEMBER OF
THE BLAIR GROUP PLAN

world. . . Those who seek a legislative remedy for every fault, real or imagined, are being stacked away every day in forgotten pigeonholes by mature people who know that the only real progress is achieved when free men remain free to work out their futures. Broadcasters are joined, in my view, by the vast majority of clergymen in seeking social changes through education and suggestion instead of governmental threats, brow-beating and regulation.—*George L. Brooks, president, KCUE Red Wing, Minn.*

TIO's sponsors

EDITOR: A recent BROADCASTING quotation from a station representative, "we now support . . . the Television Information Office," was not, in fact, true. TIO seeks its support only from broadcasters. Nonetheless, our library and other facilities are available not only to TIO's sponsors but to members of other branches of the television industry and to the community at large. We welcome all the assistance we can get in telling the story of television's problems and accomplishments as a social force.—*Roy Danish, director, Television Information Office, New York.*

FM story

EDITOR: [YOUR] FM STORY (BROADCASTING, July 29) . . . IS ANOTHER EXAMPLE OF YOUR FINE REPORTING. LET US BE THE FIRST TO ORDER 100 REPRINTS.—*W. C. Florian, president, WNIB(FM) Chicago.*

EDITOR: The special report was amazingly complete. Our order for 100 copies is enclosed.—*Harrison W. Moore Jr., manager WRVC-FM Norfolk, Va.*

(Reprints of the FM report are available at 30 cents each, 25 cents each for 100 to 500 copies and 20 cents each for over 500 copies.)

BOOK NOTE

"*Sportscasting*," by *Karl W. Klages*. Mercury Publishing Inc., Salt Lake City 11. 154 pp. \$5.00.

The author, sports information director and journalism instructor, at Utah State University, has what is essentially written a textbook, better suited to the classroom than the broadcasting studio. His experience as a play-by-play broadcaster for the Aggie Network is evident, but it would appear that novices—for whom the book appears intended—will feel after reading it that no further experience is needed before broadcasting their first game.

Although Mr. Klages emphasizes the need for experience from the ground up and offers his work as "a philosophy of approach to a sportscaster's functions" rather than the lone criterion for success behind the microphone, the book's intent may too easily be misinterpreted.

this is the house that **WJAC** *built!*



THE NEW
MILLION DOLLAR HOME
of the station serving

THE
MILLIONS OF TV VIEWERS
of Johnstown - Altoona, Pa.



Affiliated with WJAC - AM - FM
The Johnstown Tribune-Democrat Stations

NOW...GREATER FACILITIES AMERICA'S 27TH

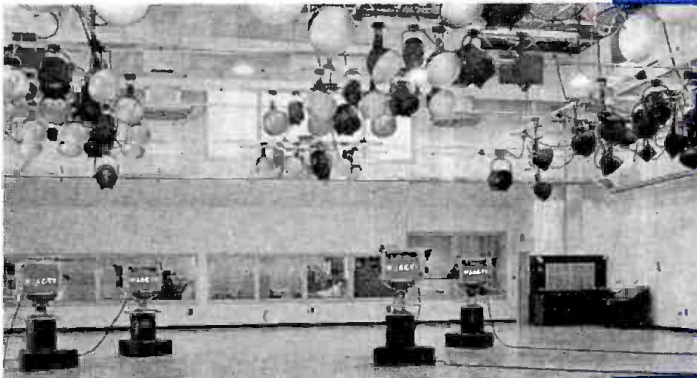

One of WJAC-TV's brand new television studios for presentation of its popular live programs.



WJAC-TV's engineering facilities boast the newest electronic equipment to deliver the best television for its viewers---and buyers



WJAC-TV's tower soars 2,890 ft. above sea level and 1,120 ft. above average terrain, to bring sponsors a bonus in viewers from all over the Allegheny area.

TV HOMES*

652,750

RETAIL SALES

\$2,456,331,000

AUTO SALES

\$473,329,000

THAN EVER bring you **LARGEST TV MARKET!**

You'll Reach
These People
Fastest Through
The Station They
Watch the Most!

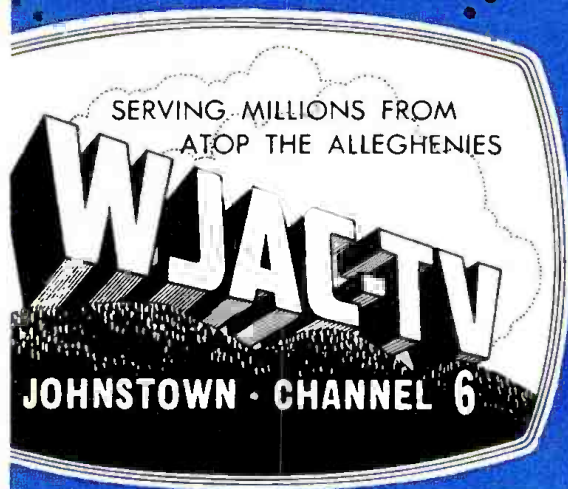

JOHNSTOWN -
ALTOONA
PENNSYLVANIA

EFFECTIVE BUYING
INCOME

\$4,042,403,000

FOOD SALES

\$648,689,000

DRUG SALES

\$69,132,000

\$3 Million (8") Mill Here Makes Bow

\$11 Million (11") Mill To Open In Few Weeks

The new 8-inch mill in the Lower Works of Bethlehem's Johnstown Plant is off and running. The facility, built at a cost of \$3 million, can produce flats, and standard and special small shapes, such as

Soon to be formally put into operation is the \$11 million 11-inch mill at the Johnstown Plant, Bethlehem Steel Co. The new mill will enhance Johnstown's competitive position in the steel in-

Labor Signs

Steel Peace For 22 Months

At least 22 months of labor peace has been assured by the signing of a new labor agreement between the United Steel Workers of America, CIO, and

Local Shops To Build 400 Over-Size Cars

Late Summer Delivery Of New 100-Ton Hoppers

Order for 400 unusually large hoppers has been placed with the Rankin Car Shops at the Johnstown Plant, Bethlehem Steel Co., The Missouri

has contracted to buy the cars which will start rolling off the production line in late spring. Delivery is scheduled for completion by the end of July or early August. While

Employment Rises Sharply in Area

Employment has risen sharply in Cambria and Somerset Counties for the third consecutive month.

The gain amounts to 1,100 according to the Johnstown office of the Pennsylvania State Employment Service. The month gain also exceeded

Joseph R. Casale, PSES manager, disclosed that the job-seeker ratio is lower than at any time since May, 1960.

The PSES reported employment of 9,800 in the work force, up from the figure of 9,700 or 13.2 per cent

Bethlehem Plans Big Outlay at New Mine

\$4 Million to \$5 Million Mineral Point Project Set--Follows \$25 Million Cambria Slope Mine

Another sizable coal mining project entailing an outlay of \$4 million to \$5 million has been launched in Cambria County by Bethlehem Mines Corp.

River. It will be known as Brookdale Mine 77. Mr. Chalfant said the Brookdale Mine 77 cleaning and preparation plant

Raw coal from the new mine at Brookdale will be delivered to the

HEADLINES THAT TELL OF A COMMUNITY ON THE RISE

JOHNSTOWN, PA.

Gigantic Power Project Planned For Johnstown, Penna., Area

1,200 New Jobs Created and \$350 Million To Be Spent

Eighteen major utilities join in the erection of the Keystone Electric Generating Station, one of the largest mine-mouth generating stations in the country.

The new plant will use up to 4,700,000 tons of coal

annually. The new generating station is expected to provide an abundance of electrical power for the whole Middle Atlantic region. The station will be located in the bituminous coal fields of Western Pennsylvania, of which Johnstown is the center.

Welfare Case Load Lowest Since 1961

A sign of improvement in the local employment situation is reflected in the caseload report of Cambria County Board of Assistance, Office of Public Assistance of Pennsylvania Department of Public Welfare (DPW).

Edward R. Golob, executive director, informed the board that at the close of business Tuesday, the load was down to 4,442 cases, the lowest since the "false low" of 4,429 June 23.

Jobless Claims At 5-Year Low

State unemployment compensation claims here hit a 5-year low in May.

The decline, following an equally sharp dip in April, is pointed up in a report by Joseph R. Casale, manager of the Johnstown office of the Pennsylvania State Employment Service.

In May, the PSES received 1,529 new and 12,727 continued applications for jobless pay. By way of contrast the comparable figures for January of this year were 3,919 and 27,949. Since then claims have been on a steady slide.

Mr. Casale said jobless pay claims are

The above stories have appeared recently in The Tribune-Democrat, Johnstown's daily newspaper

WJAC-TV

CHANNEL 6

WJAC-AM

850 KC
10,000 WATTS

WJAC-FM

95.5 MC
57,000 WATTS

Represented by HARRINGTON, RIGHTER & PARSONS, INC.

THE JOHNSTOWN TRIBUNE-DEMOCRAT STATIONS

COMMERCIAL MAKERS BUSIEST EVER

- Television advertisers more interested in color this year
- Price stability improves as bidding system loses favor
- Specter of fall AFTRA-SAG negotiations hovers in background

The production of TV commercials for the 1963-64 season is heading into peak activity this month amid signs that volume will be the heaviest in recent years and that color commercials are growing significantly in number.

A check by BROADCASTING last week of officials at advertising agencies and commercial production companies also indicated that a measure of stability is being introduced into the industry because of a diminishing reliance on the bidding system of selecting outside producers, though this system has not been abandoned by any means.

cluding overhead, salaries, prices of equipment and raw stock.

Hovering over the pricing situation, however, is the upcoming negotiation, this fall, of the American Federation of Television & Radio Artists and the Screen Actors Guild with advertisers, agencies and producers. The key issue undoubtedly will be a formula for residuals, which has been a thorn in the side of management since 1960 when the most recent contract covering filmed and taped commercials was formulated.

Tough Formula ■ "The residual formula that was negotiated by the

however, that it was their feeling that agencies were cognizant of high residual costs and therefore had the tendency to negotiate more sharply with them on production of commercials.

These were some of the reasons cited by producers and agencies for the improved economic base of the commercial production business:

■ Though the bid system still is used, agencies tend to shop around among fewer companies on a particular job, lessening sharp competition and restricting the negotiation.

■ There has been a reduction in the



Commercial producers are nearing their top season as advertisers and agencies get ready for fall. A growing use of graphics combined with live



action is noted as illustrated in this commercial (l) produced by Film-makers Inc., Chicago, for Continental Casualty Co. through MacManus, John

& Adams. Others prefer a more casual, relaxed situation as typified by the commercial produced for Farmhouse Donuts (r), by Elektra Film.

The generally optimistic picture projected by outside producers and agency executives was in sharp contrast to the atmosphere in the past few years (BROADCASTING, July 30, 1962) when production companies charged that low prices were prevalent as a result of the bidding system and the "overpopulation" of producers.

Prices for producing commercials will be slightly higher than last year, a consensus of experts indicates. They noted that increases reflect regular rises in normal operating expenditures, in-

networks was a rough one for the advertisers involved in spot commercials," one agency executive commented. "I don't see how we can roll back the residual formula, but I'm sure that the advertisers and agencies, who are going to take a leading role in the negotiations, are going to do their best to soften the blow this time around."

Both producers and agencies acknowledge that the talent residual situation should have no bearing on the commercial production business. Production company executives stressed,

number of companies in the field, with several large and many small organizations closing up shop.

■ Both the agencies and production companies (and some advertisers) have instituted stronger cost control units, whittling down expenses wherever possible and enabling agencies and producers to operate more efficiently and more profitably.

There was no unanimous opinion on whether more or fewer commercials are being produced for next year, as compared with recent years. A majority of

those canvassed said they were producing fewer commercials for most clients but many were producing for more clients than in past years. Some noted they were producing as many commercials per client but that a smaller number of commercials actually would reach the air for large-scale campaigns.

William Gibbs, vice president of Television Graphics Inc., voiced the belief that just as many or more commercials are being produced today, but that fewer actually are reaching the air because many are dropped after test periods.

He explained that the main concern of an advertiser should be the value of a commercial to the media buy, which may run into \$300,000 or \$400,000. Accordingly, only the commercials that the agencies and advertisers consider the most effective eventually remain on the air for regular campaign.

Pick Companies ■ Mr. Gibbs, a former J. Walter Thompson executive, said he has observed that agencies are still relying on the bidding system, but tend to go to a few companies they consider best suited for a particular assignment and negotiate a price and a contract.

The accent on cost-consciousness was sounded by several agency men and was detailed by Gordon Webber, vice presi-



William Gibbs, of Television Graphics, says fewer commercials reach the air.

dent and director of broadcast commercial production, Benton & Bowles, who said:

"In the past year, we have attempted to reduce promotion costs more than ever before, and have a department which makes up its estimates of costs and then compares them with actual costs. Though we use the bidding as the standard, as do many agencies, efforts are being made in some way to get away from it by use of the negotiated bid, for example. This means we

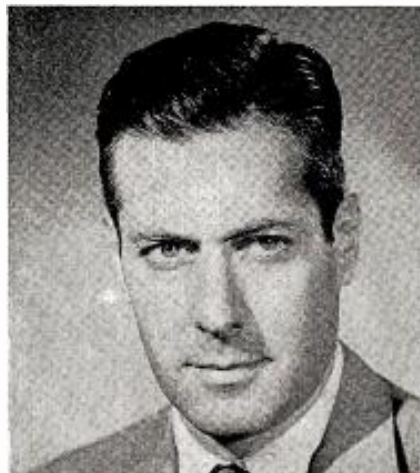

Robert Bergmann, of Filmex, likes the casual, low pressure approach.

go directly to a company or two which we feel will do the best job, ask for their bid, and then negotiate the price."

A production executive at a top agency, who is charged with responsibility over costs, noted that while fixed costs (talent, unions, cameramen, directors) have gone up, revision costs have gone down. This indicates, he said, either that outside producers are more careful or that the clients are less demanding. He observed that the attention paid to costs and the insistence on more detailed specification of costs has also worked to the benefit of the production houses, which now obtain a clearer view of the cost picture and can adjust their original bids, if necessary.

Color Gains ■ The growing importance of color was accentuated by several producers and agency men, who noted that a larger number of advertisers were ordering color commercials. They were reluctant to identify the color clients, citing competitive considerations, but said the reason for the expansion was that color is becoming a more important factor in some major markets because of the steady rise in the number of color receivers.

One development mentioned in hushed tones by several producers and agency men is a move toward using more Negro performers in spots. Several noted they have been employing Negroes in commercials to a larger extent, and one producer added:

"We have, in fact, shot sequences to old commercials, adding Negroes and splicing them in. And this is not unique to our shop. Nobody likes to talk about it, because it's a kind of touchy situation."

What are some of the trends in commercial TV techniques? There were variations, depending on producers and the agency men approached, but among

those mentioned were live action commercials; a combination of live action plus graphics; so-called slice-of-life realism; documentary commercials.

But there was a feeling the casual, soft-sell approach would steal the scene next season.

Robert Bergmann, president of Filmex, offered these observations:

"We've found that commercials are most effective when they engender excitement for the product—and stop-motion can be useful here—and when they become involved with people. The so-called documentary technique in which a housewife gives her candid opinion of a product while involved in a home-life surrounding can be most convincing. We lean here at Filmex to a casual, low-pressure approach."

Lincoln Schuerle, president of Film-maker Inc., believes that the interview technique in commercials may have been "abused" but said it will be improved and will expand. He also envisions an increase in live action plus graphic spots and in the use of performers who do not have "the professional look." Sound is one area in the TV commercial field which needs improvement, Mr. Schuerle said, adding that "we sometimes forget that TV is not just sight but sound too."

Perhaps the two most pressing problems facing the TV commercials production industry are the long-range one of the bidding system (and what can replace it) and the immediate one of the SAG-AFTRA negotiation. These subjects were mentioned repeatedly by both agency men and producers.

The upcoming union negotiations constituted a topic treated by these management officials with considerable concern. Several agency men claimed that SAG and AFTRA have attained



Gordon Webber, Benton & Bowles, negotiates with quality producers.

goals that should satisfy the unions without seeking additional gains. There was some fear that the AFTRA-SAG residual pattern might be sought by technical unions.

The consensus seemed to be that AFTRA and SAG had reached optimum conditions and additional demands upon producers and agencies might well be "a breaking point."

Several producers and agency officials mentioned that there is consider-



Lincoln Schuerle, Filmmaker Inc., likes interview technique in spots.

able research in progress to find a replacement for the bidding system.

Samuel Zurich, assistant managing director of the commercial production department at N. W. Ayer & Son, acknowledged that Ayer is one agency that is researching this subject, and added: "But we haven't come up with a solution yet."

At present, Ayer asks three producers to bid for a job, specifying (1) cost estimate and (2) the creative contribution the outside producer can make to the assignment. Mr. Zurich said the agency is not satisfied with the so-called bid system and hopes to evolve a more "fool-proof" method of selecting the "best" producer for a specific job.

Mickey Dubin, vice president for sales and administration for Sarra Inc., offered one suggestion to agencies that may help in making better commercials and bringing costs down—send your order in sooner. He said that business for Sarra came in later than usual and the company is "just beginning to roll." If agencies can persuade their clients to give approval earlier, the outside producer can spend more time and effort on the advertiser's commercial, Mr. Dubin said.

A large increase in the demand for live action commercials was noted by

Abe Liss, creative director, Elektra Film Productions, New York.

Mr. Liss said that while business in animated commercials is about the same as a year ago, the demand for live action commercials has doubled.

He attributed the rise in live action films to a trend toward more and more realism in commercials. "Audiences are becoming more sophisticated and they desire more realism and believability in commercials."

Tareyton account switches to BBDO

In what may be the largest account switch of the year to date, the American Tobacco Co. announced last week it has awarded its Dual Filter Tareyton cigarette business to BBDO, replacing the Lawrence C. Gumbinner advertising agency.

A spokesman for American Tobacco said Tareyton would bill "close to \$12 million," though authoritative trade sources estimated the account in 1962 billed closer to \$7 million.

They pointed out that for 1962, Television Bureau of Advertising figures show Tareyton spent about \$3.3 million in TV, and Publishers' Information Bureau figures show that the cigarette brand invested about \$3 million in newspapers and magazines combined. They doubted that the company had spent more than \$1 million in non-measured media.

The shift of the account marks the



Mickey Dubin, Sarra Inc., urges buyers to come early and avoid the rush.

end of a 38-year relationship between Gumbinner and the American Tobacco Co. In 1925 the agency obtained American Tobacco's Tuxedo pipe tobacco business and in 1928 it began to



Abe Liss, of Elektra Film Productions, sees big demand for live action.

handle the Roi-Tan cigar account, which recently moved to Gardner Advertising.

Robert B. Walker, president of American Tobacco, said the change was being made to "consolidate media planning and billing with consequent related advantages." BBDO has handled the company's Lucky Strike account since 1948.

Advertising for American Tobacco's Pall Mall cigarettes and Montclair cigarettes will continue with Sullivan, Stauffer, Colwell & Bayles. The BBDO appointment is effective Nov. 1.

Other large agency account switches this year: the \$8 million Beech-Nut business from Young & Rubicam to Benton & Bowles and the \$6 million VO5 shampoo account from BBDO to J. Walter Thompson.

ABC-TV announces AFL telecast sponsors

ABC-TV announced last week that nine advertisers will sponsor a schedule of 40 American Football League games on 17 dates this fall and winter, beginning with two games on Sunday, Sept. 8 and running through the league play-off game late in December.

Sponsors for the telecasts will be the Gillette Co. (through Maxon), the Lincoln-Mercury division of Ford Motor Co. (Kenyon & Eckhardt), the Good-year Tire and Rubber Co. (Young & Rubicam), P. Lorillard (Grey), American Gas Association (Lennen & Newell), Liberty Mutual Insurance Co. (BBDO), Pearl Brewing Co. (Tracy-Locke), Sun Oil Co. (William Esty), Chesebrough-Pond's Inc. (Norman, Craig & Kummel) and Union Carbide Corp. (William Esty).

Coffee TV spending up 7% in 1962

The coffee industry spent some 7% more money in television in 1962 than in 1961, but advertising by the 11 biggest spenders fell by some 5%, according to Television Bureau of Advertising figures.

Coffee spending was up from \$40.3 million to \$43.1 million, although spending of the top 11 was off from \$36.7 million to \$34.9 million.

Television accounted for 91.1% of

the advertising budgets of the top 11 coffee advertisers. Of 19 brands produced by the 11 companies, seven brands used television as their only measured advertising medium.

Most of the coffee money went into spot television—\$37 million—with \$6.1 million being placed in network shows. For its industry-wide statistics, TvB based its figures on the advertising of 20 companies which produce 27 different brands.

Biggest spender of the group was General Foods Corp., producer of Maxwell House, Yuban and Sanka. General Foods spent \$13.3 million in television in 1962, a drop of some \$1.2 million from its 1961 figure. Five of the top 11 showed budget reductions from 1961 to 1962 in television, but the other 14 companies represented in the TvB figures made up for the slack and boosted the spending by almost \$3 million.

LEADING COFFEE ADVERTISERS IN 1962
GROSS TIME AND SPACE BILLINGS

	Network TV	Spot TV	Total TV	Magazines	Outdoor	Newspapers	Total	% TV
General Foods Corp.	\$4,725,180	\$ 8,591,290	\$13,316,170	\$ 980,097	\$ 76,779	\$ 661,048	\$15,034,094	88.6
Maxwell House	2,796,300	5,135,340	7,931,340	8,300	339,594	8,279,234	95.8
Sanka	1,213,553	25,000	1,238,553	950,496	76,779	228,474	2,494,302	49.7
Yuban	715,327	3,430,950	4,146,277	21,301	92,980	4,260,558	97.3
J. A. Folger Co.	1,575	4,749,270	4,750,845	263,600	5,014,445	94.7
Standard Brands	184,757	4,031,850	4,216,607	311,515	566,071	5,094,193	82.8
Chase & Sanborn	184,757	3,773,130	3,957,887	152,415	528,150	4,638,452	85.3
Siesta	258,720	258,720	159,100	37,921	455,741	56.8
Nestle Co. Inc.	1,167,311	2,096,680	3,263,991	9,230	259,399	3,532,590	92.4
Decaf	452,327	74,900	527,227	527,227	100.0
Nescafe	714,984	2,021,780	2,736,764	9,230	231,897	2,977,861	91.9
Nestle's	27,502	27,502
Hills Bros. Coffee Inc.	13,635	2,559,810	2,573,445	2,573,445	100.0
Nat. Fed. of Coffee Growers of Colombia	1,662,750	1,662,750	1,662,750	100.0
M. J. B. Co.	1,570,050	1,570,050	1,570,050	100.0
Chock Full O' Nuts Corp.	20,243	1,165,610	1,185,853	48,889	1,234,742	96.0
Paxton & Gallagher & Co.	1,132,540	1,132,540	1,132,540	100.0
Butternut	1,132,540	1,132,540	1,132,540	100.0
Beech-Nut Life Savers Inc.	1,010,020	1,010,020	18,183	1,028,203	98.2
Beech-Nut	503,820	503,820	18,183	522,003	96.3
Martinson's	506,200	506,200	506,200	100.0
S. A. Schonbrunn & Co.	290,300	290,300	108,643	111,795	510,738	56.8
Savarin	290,300	290,300	290,300	100.0
Brown Gold Coffee	7,064	7,064
Medaglia D'Oro	101,579	111,795	213,364
Total:	\$6,112,703	\$28,859,868	\$34,972,571	\$1,409,485	\$340,379	\$1,665,385	\$38,387,790	91.1%

Sources: Television: TvB-Rorabaugh and LNA-BAR
Newspapers: Bureau of Advertising

Magazines: Leading National Advertisers
Outdoor: Outdoor Advertising, Inc.

Rep appointments . . .

- KARD-TV Wichita, Kan.: Edward Petry & Co., New York, as exclusive national representative.
- KBMT-TV Beaumont-Port Arthur, Tex.: Roger O'Connor, New York, named exclusive national representative.
- KAIT-TV Jonesboro, Ark.: The Devney Organization Inc., New York, as national representative.
- KCUB Tucson, Ariz.; KOSI Denver, and WHNT(TV) Huntsville, Ala.: Venard, Torbet & McConnell Inc., New York, named exclusive national representative.
- WBCN(FM) Boston, WHCN(FM) Hartford, Conn., and WAJM(FM) Montgomery, Ala.: Herbert E. Groskin & Co., New York, appointed representative.
- WAZE Clearwater, Fla.; WBZY Torrington, Conn.; WALE Fall River, Mass.;

Milt Grant Show Network, and Massachusetts Bay Buy group of stations: Vic Piano Associates, New York, appointed national representative.

- WHK-FM Cleveland: Roger Coleman, Inc., New York, appointed national representative.
- WAKE Atlanta: Kettell-Carter Inc., Boston, as New England sales representative.
- WDEE Hamden, Conn.: Advertising Time Sales, New York, effective Aug. 2.

Agency appointments...

- Maradel Products, New York, has appointed Mogul, Williams & Saylor, New York, as agency for toiletry items formerly handled by Donahue & Coe and Kastor, Hilton, Chesley, Clifford & Atherton. MW&S picks up \$430,000 in billings and now handles \$1.35 million of Maradel's total billings of \$1.5 mil-

lion. Balance is retained by Daniel & Charles and Ted Gotthelf Associates.

- Hess & Clark, Ashland, Ohio, a division of Richardson-Merrell Inc., has signed Cooper, Strock & Scannell Inc., Milwaukee. The feed medications and animal health products firm's account bills in excess of \$1 million.
- The Tussy Division of Lehn & Fink, New York, has named the Kudner Agency, replacing Young & Rubicam. The account bills approximately \$1 million, with about \$250,000 in spot TV, and includes various cosmetics and toiletries.
- The Alliance Manufacturing Co., Alliance, Ohio, has named Nelson Stern Advertising, Cleveland, to handle all advertising and marketing for Alliance Tenna-Rotor and Genie Garage Door Operator. The campaign, which will include saturation spot TV, is budgeted at \$550,000.

We suppress the news (and our audience likes it that way)

A breathless, blown-up version of how Mrs. Murphy dented her fender is the kind of news we don't report.

We don't shout — to be heard. We speak softly, but carry plenty of what our listeners want to hear (legitimate news) — when they want to hear it (now).

That's how WFAA has learned to grab attention and hold it with the "news more people quote."

And advertisers approve. They know it works.

News that's actual, factual, in-depth, and often.

In all, nearly 30 hours a week. Including something like 210 features—weather, sports, farm, business, women, etc. — plus regularly scheduled NBC reports. Not to mention thorough, continuous regional, state, and local coverage by WFAA's Southwest Central News staff of 16 full-time reporters, stringers in every

Southwest city and town worth mentioning, and four mobile news cruisers on 24-hour call.

Providing news that informs. The kind that people turn on, tune in, listen for, and believe in.

This makes for loyalty. And an audience that *responds*. At least, that's been our experience and that of our advertisers. Let it be *your* experience too.

Begin by calling your Petryman.



WFAA-AM-FM-TV
Communications Center / Broadcast services of The Dallas Morning News / Represented by Edward Petry & Co., Inc.

NETWORKS' HAPPY DAYTIME

Fourth-quarter TV selling well ahead of 1962; ABC and CBS near sellout; NBC at 92% level

A bullish pace at each of the TV networks in sales of next season's daytime schedules indicates another record fourth quarter and continuation of a three-year trend of stronger advertiser response to network daytime programming.

ABC-TV and CBS-TV are virtually sold out in daytime, and NBC-TV is moving forward to SRO status. Network sales personnel are ready with reasons to account for the quickened activity.

Yale Roe, director of daytime sales at ABC-TV, where the sales rate is now estimated to be one month ahead of last year, attributes the brighter picture there to a "fully documented" daytime lineup. Track records for all but two shows in the schedule have been registered "on ABC air" and newcomers, *Price Is Right* (moving from NBC-TV) and *Trailmaster* (repeats of *Wagon Train*) have "established" themselves elsewhere.

Mr. Roe contrasts this lineup to last year when ABC-TV was "selling on the come" for three new daytime shows. Fourth quarter Monday-Friday daytime business already signed by ABC is estimated at \$15 million based on standard card rates.

Higher Prices ■ According to network sources, four half-hours in ABC daytime strips are bringing prices 50% higher than the network's "traditional" rates. Minutes in the *Tennessee Ernie Ford Show*, *Price Is Right* and the 60-minute *Trailmaster* series may now sell at \$3,600, depending on frequency, where previously the going rate for an ABC-TV daytime minute, purchased at the same frequency, was approximately \$2,400.

New programs in next season's NBC-TV daytime schedules are the exception rather than the rule. The network will start in September with three new game shows—*Word For Word*, *Missing Links* and *The Match Game*—and two recently started—*People Will Talk* and *You Don't Say*.

NBC-TV's daytime programs are approximately 92% sold in the fourth quarter, a figure representing an estimated \$20 million worth of business at standard card rates. A similar study of daytime network sales conducted by BROADCASTING last year showed NBC-TV sold at a 90% level at the same time a year ago.

Bob McFadyen, manager of daytime sales at NBC-TV, sees the network's healthy daytime financial picture as based on both increased affiliate clear-

ances and longer lineups bought by individual sponsors. The average number of affiliate clearances in the coming season for daytime programs is 176, compared to 168 last year. And the average lineup bought by sponsors is up 15 stations from 150 last year to 165. The network reports that eight of its 12 daytime half-hours are completely sold and the four remaining half-hours are 70% sold. Its four news strips are sold out.

One Change ■ CBS-TV has preferred not to tamper with its Monday-Friday daytime schedule, the only change being the discontinuance of *The Millionaire* (4:30-5 p.m.) and allocation of that period to local station time.

Advertiser response to the status quo schedule has gratified the sales department to the extent that the schedule was sold out early in July. A spokesman for CBS-TV noted that this pace outstripped last year's record for fourth-quarter sales.

Under CBS-TV's "Morning Minute Plan" all time between 10 a.m. and noon is sold by the minute. When the plan was introduced in 1961 it met initial "lukewarm" reception (fourth quarter 50% sold by the end of July). And last year there were scattered minutes remaining at this point com-

pared to this year's sold-out record.

Morning minute prices at CBS-TV have gone up \$300 across the board and now range from \$2,300 to \$3,100 in summer and \$2,800 to \$3,500 in winter. Afternoon time which CBS-TV sells as quarter-hour program buys will be "slightly more expensive" in the coming season than last year, reflecting higher program costs.

Weekends, Too ■ Saturday programming on each of the networks has also sold well ahead of last year's pace. The Saturday schedule at CBS-TV is totally sold for the fourth quarter with the exception of an alternate quarter-hour in the *Alvin* show and the network's new children's educational series, *Do You Know*, which has been slotted at 12:30-1 p.m.

NBC-TV reports its Saturday schedule 91% sold in the fourth quarter. Biggest boon to NBC Saturday sales has been the sellout of its education program *Exploring*, completed recently with half program sponsorship signed for by Encyclopaedia Britannica.

ABC-TV's Saturday-morning schedule was virtually sold out for the fourth quarter, early in May, according to the network.

State liquor board censors beer commercials

A proposed radio advertising campaign for a regional beer brand has been "censored" by the Washington State Liquor Control Board in a decision causing great concern among the

May network TV time billings

	NETWORK TELEVISION GROSS TIME BILLINGS					
	May			January-May		
	1962	1963	% Change	1962	1963	% Change
ABC	\$17,227,296	\$18,339,070	+ 6.5	\$ 84,659,058	\$ 91,991,624	+8.7
CBS	25,380,092	27,924,088	+10.0	124,362,088	131,097,520	+5.4
NBC	23,494,373	25,304,188	+ 7.7	115,029,097	121,006,868	+5.2
Total	\$66,101,761	\$71,567,346	+ 8.3	\$324,050,243	\$344,096,012	+6.2

	MONTH-BY-MONTH 1963			
	ABC	CBS	NBC	Total
*January	\$18,264,011	\$25,912,636	\$24,065,431	\$68,242,078
February	17,435,404	24,058,084	22,849,778	64,343,266
*March	19,377,056	26,694,018	25,166,096	71,237,170
*April	18,576,083	26,508,694	23,621,375	68,706,152
May	18,339,070	27,924,088	25,304,188	71,567,346

(*January, March and April figures changed as of July 26, 1963)

	BY DAY PARTS					
	May			January-May		
	1962	1963	% Change	1962	1963	% Change
Daytime	\$20,372,002	\$23,577,629	+15.7	\$101,511,035	\$116,767,316	+15.0
Mon.-Fri.	17,271,749	19,670,934	+13.9	83,887,427	94,198,310	+12.3
Sat.-Sun.	3,100,253	3,906,695	+26.0	17,623,608	22,569,006	+28.1
Nighttime	45,729,759	47,989,717	+ 4.9	222,539,208	227,328,696	+ 2.2
Total	\$66,101,761	\$71,567,346	+ 8.3	\$324,050,243	\$344,096,012	+ 6.2

Source: TVB/LNA-BAR

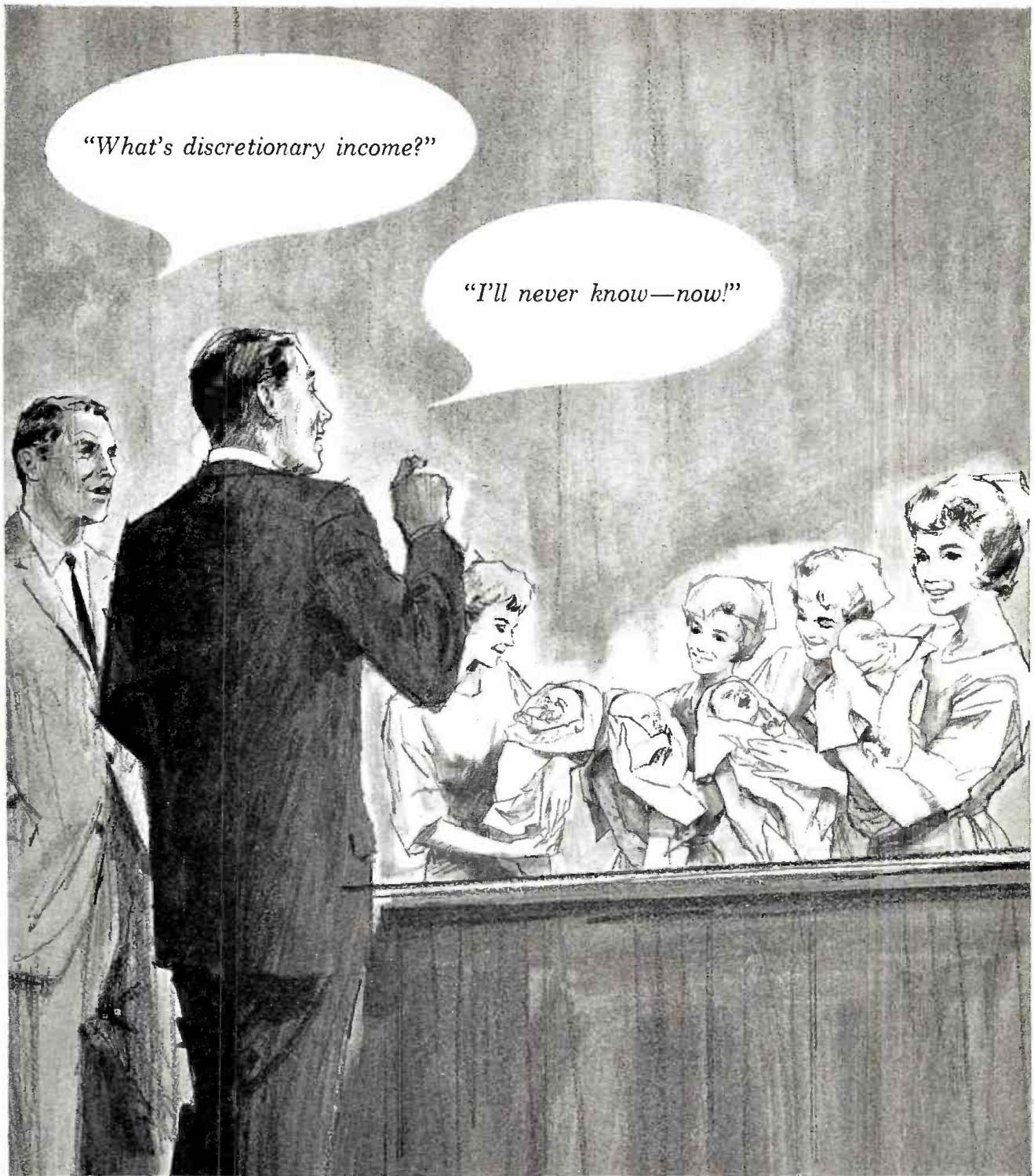

His chances of knowing may not be quadrupled—
 but they're better in Ohio's **THIRD MARKET**—
 with 27 percent more discretionary income (on the
 national average). Millions of people with this ad-
 vantage are entertained and informed by **WHIO-TV-
 AM-FM**. Quadrupler George P. Hollingbery can tell
 you how to bottle up this market.

Additional morsel for thought:

*Good Labor-Management Relations, Less idle-
 ness through work stoppages than any city its
 size, last ten years. (Source: Dayton Area
 Chamber of Commerce.)*

Associated with **WSB, WSB-TV**, Atlanta, Georgia,
WSOC, WSOC-TV, Charlotte, North Carolina
 and **WIOD-AM-FM**, Miami, Florida



DAYTON, OHIO • WHIO • AM • FM • TV

state's broadcasters and advertisers.

James A. Murphy, president of the Washington State Association of Broadcasters, said the recent liquor board decision has left advertisers in the state in a quandry on planning their campaigns and has cost the industry clients. An appeal will be made to the board, he said.

Of the two beer commercials involved in the decision, one depicted an outing in the woods with this commentary, in part: "Mid-afternoon and you're in the middle of nowhere. New mountain trail. Just saw a fawn. Cool, green, pine-y. Great time for a cool beer."

The ruling: "The board will have no objection to the 'outing' commercial, provided that the sentence 'Great time for a cool beer' is deleted. The board feels that this sentence is suggestive of consumption in a public place [the forest]."

A second beer commercial telling of a lazy, comfortable day on a yacht was rejected in its entirety by the liquor board on the grounds "boats and alcoholic beverages do not mix."

Mr. Murphy said broadcasters and advertisers are disturbed by the principles involved in the board's action. "For years the broadcasters in this state have rigorously adhered to a self-imposed voluntary guide to good practice and taste," he said, and have been able in the past to discuss mutual problems with the Liquor Control Board. "The recent actions taken by the board, however, were taken unilaterally on the part of the board without consulting industry," he said.

For adults only?

Cigarette advertising is "more adult than ever," if BBDO's new radio spot campaign which began last Monday (July 29) for Lucky Strikes is any indication.

The commercial jingle line states that "Luckies separate the men from the boys, but not from the girls."

The commercial was recorded July 22, 12 days after the Tobacco Institute had released an official statement of policy that "it is not the intent of the industry to promote or encourage smoking among youths."

Following the introductory jingle line of the commercial, an announcer says, "Smoking's a pleasure meant for adults. And Luckies are blended for adult tastes. If you're an adult smoker, remember: LS/MFT—Lucky Strike means fine tobacco."

Lieutenant, The Virginian, Sing Along With Mitch, International Showtime, The Joey Bishop Show, Saturday Night at the Movies, Report From . . ., and NBC News specials.

J. B. Williams Co., through the Parkson agency, has purchased alternate-week quarter-hour sponsorship in the expanded *Huntley-Brinkley Report* on NBC-TV (Monday-Friday, 7-7:30 p.m.). The network said the half-hour program is now 90% sold, with previously announced sponsors R. J. Reynolds Tobacco (through William Esty), American Home Products (Ted Bates), American Chicle (Ted Bates), Aluminum Co. of America (Fuller & Smith & Ross), Plymouth Division of Chrysler Corp. (N. W. Ayer), and Standard Brands (J. Walter Thompson).

Minnesota Mining and Manufacturing Co., through Erwin Wasey, Ruthrauff & Ryan, will sponsor NBC-TV's two-day coverage of the Bing Crosby National Pro-Amateur Golf Tournament from Pebble Beach Golf Club in California (Saturday, Jan. 18, 1964, 5-6 p.m. EST and Sunday, Jan. 19, 5-6:30 p.m. EST). In conjunction with the TV sponsorship, the 3-M company is also conducting a "Beat Bing" contest in which golfers all around the country try to beat a score posted by Mr. Crosby when he plays a round Aug. 24 in St. Paul. The 27 leaders will compete in a playoff tournament, and the three winners will play in the Bing Crosby Oper with free trips to the tournament.

Tidy House Division of Pillsbury Co will sponsor *The Lee Phillip Show*, a weekday program for women to be broadcast over more than 40 midwestern stations of the CBS-TV network beginning Sept. 2 (Monday-Friday, 3:30-3:45 p.m. CDT). The program will originate in Chicago. Agency is McCann-Marschalk.

Rayette Inc., St. Paul, has purchased participations in ABC-TV's *Jerry Lewi Show* starting Sept. 21 (Saturday, 9:30-11:30 p.m. EDT). The buy introduces Rayette to network television. Advertising agency: Taplinger, Millstein, New York.

Household Finance Corp. has purchased half sponsorship of Notre Dame football games on ABC Radio. The other half will be open for local station sale. Needham, Louis & Brorby is the advertising agency. **United Motor Service Division** of General Motor Corp. will sponsor the network's half of the 10-minute pre-and-post-game shows. Agency is Campbell-Ewald Co.

Bristol-Myers Co., through Young & Rubicam, has bought into 10 NBC-TV programs for the fall season—*The Bill Dana Show, Espionage, Temple Hous-*

Business briefly . . .

Purex Corp. through Edward H. Weiss agency has purchased *Purex Presents Lisa Howard and News, With the Woman's Touch*, weekday news report, to be presented on ABC-TV beginning Monday, Sept. 9 (2:55-3 p.m. EDT).

Goodyear Tire & Rubber Co., through Young & Rubicam, has purchased participations in 12 NBC-TV programs for this season—*The Bill Dana Show, Mr. Novak, Espionage, Temple Houston,*

Commercials in production . . .

Listings include new commercials being made for national or large regional radio or television campaigns. Appearing in sequence are names of advertiser, product, number, length and type of commercial, production manager, agency with its account executive and production manager. Approximate cost is listed, where given by producer.

Century Productions, Goldwyn Studios, 1041 North Formosa Avenue, Hollywood 46.

Bulova Watch Co., four 50's, four 26½'s for TV, live on film. Agency: Sullivan, Stauffer, Colwell & Bayles. John Rigor, account executive. Robert Warhola, agency producer.

Bulova Watch Co. Ltd., twelve 10's for TV (six in English, six in French), live on film.

Lincoln-Mercury Dealers Association (Lincoln, Mercury and Comet), two 60's for theatrical distribution, live on film. Agency: Kenyon & Eckhardt. Samm Coombs, account executive.

Pepper Sound Studios Inc., 2076 Union Avenue, Memphis 4.

Guy Mobile Homes, one 60 for radio (jingle). Hub Atwood, production manager. Approximate cost: \$1,300.

Mammy's Cafeterias, one 60 for radio (jingle). Bud Smalley, production manager. Agency: At-

kins & Holchale. C. Atkins Jr., account executive. Approximate cost: \$1,300.

Gold Strike Stamps, Salt Lake City, one 60 for radio (jingle). Edwin Hubbard, production manager. Agency: Harris & Love. Donald Ware, account executive. Approximate cost: \$1,300.

Quality Stamps, one 60 for radio (jingle). Vincent Trauth, production manager. Agency: Air Press Advertising. Tony Bernander, account executive. Approximate cost: \$1,300.

Lytton's Department Store, Chicago, one 60 for radio (jingle). Joe D'Geralamo, production manager. Approximate cost: \$1,300.

Blue Boy Dairy, Rochester, N. Y. (ice cream), two 60's for radio (jingles). Ernie Bernhardt, production manager. Agency: Hart-Conway. Approximate cost: \$2,600.

Shield Productions Inc., 919 North Ernst Court, Chicago 11

B. F. Goodrich P-F Fliers (sneakers), one 60 for radio (jingle). Agency: Foote, Cone & Belding. John Rundall, agency producer.

International Harvester (tractors), one 60 for radio (jingle). Agency: Foote, Cone & Belding.

Norge Dry Cleaning, one 60 for radio (jingle). Agency: Clinton E. Frank. Jack Lawrence, account executive.

Curtis Industries (caulking), one 60 music track for TV. Agency: MacFarland, Aveyard. Nick Amos, agency producer.

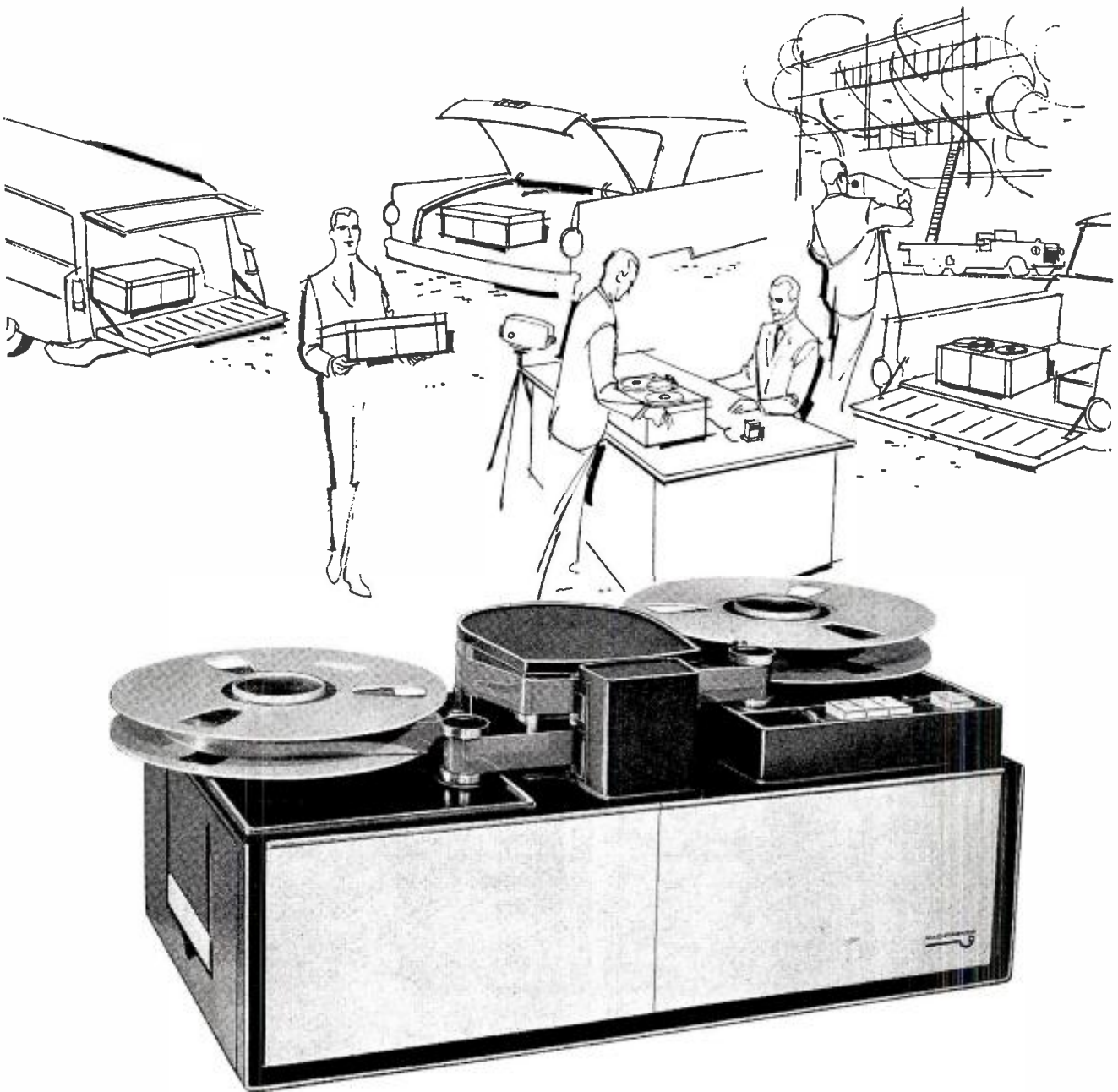

First TRULY Portable Television Tape Recorder!

available now. The Machtronics MVR-15 . . . world's first *truly* portable television tape recorder . . . 68 pounds of versatility and economy that will operate from any 110-volt AC wall outlet. For most occasions it becomes the answer to needed mobility . . . for others, sights and sounds of broadcast quality television tape recording are now at a cost they can justify. And yes, tape is *interchangeable!* Manufactured by Machtronics, Inc. — distributed exclusively for all broadcast purposes by Storer. For further information, call or write STORER PROGRAMS, INC., Plaza 2-7525, Five Hundred Park Avenue, New York, New York 10022.



Storer
Programs
INCORPORATED

ton, *The Lieutenant*, *The Virginian*, *Sing Along With Mitch*, *International Showtime*, *The Joey Bishop Show*, *Saturday Night at the Movies*, and NBC News specials.

The National Oil Fuel Institute will begin a TV spot campaign in eight test markets in September. The markets are Albany, N. Y.; Harrisburg, Pa.; Milwaukee; Providence, R. I.; Cincinnati; Hartford, Conn.; Des Moines, Iowa, and Richmond, Va. The campaign will support local fuel oil dealers and distributors in promotion of oil heat for home use. Agency: Fuller & Smith & Ross, New York.

Borden Foods Co., New York, has scheduled a major TV campaign in mid-August to introduce Dutch chocolate drink, a refrigerated version of its instant Dutch chocolate flavored mix. The company has purchased sponsorship on ABC-TV's Paul Winchell and Jerry Mahoney show and *Cartoonies*; NBC-TV's *Shari Lewis Show* and CBS-TV's *Captain Kangaroo*. Commercials to reach adults will be broadcast on NBC-TV's *Say When*, *Play Your Hunch*, *The Price Is Right*, *Concentration*, *Your First Impression*, *You Don't Say*, Loretta Young and *Make Room for Daddy*. Agency: Young & Rubicam.

Encyclopaedia Britannica Inc., Chicago, through McCann-Erickson, Chicago, has bought one-half of NBC-TV's *Exploring*, a children's series starting in the fall (Saturday 1-2 p.m.).

Eight advertisers have purchased sponsorship in NBC-TV's *Temple Houston*, one-hour western series beginning Sept. 19. The advertisers are: John H. Breck Inc. (Young & Rubicam); Bristol-Myers (Young & Rubicam); Buick Motor Division of General Motors Corp. (McCann-Erickson); Goodyear

Tire & Rubber Co. (Young & Rubicam); H. J. Heinz Co. (Maxon Inc.); S. C. Johnson & Son (Needham, Louis and Brorby); Lehn & Fink Products Corp. (Geyer, Morey & Ballard); and Pharmcraft Laboratories (Papert, Koenig, Lois).

Xerox buys documentary

The Xerox Corp., Rochester, N. Y., has purchased sponsorship of *The Crisis*, a new ABC-TV one-hour documentary scheduled for fall presentation. The documentary is an on-the-spot film of a June 10-11 discussion between President Kennedy and Attorney General Robert F. Kennedy concerning desegregation of the University of Alabama.

The film was taken as the President and Attorney General talked of what to do if Alabama Governor George C. Wallace interfered with the registration of two Negroes at the university. Another camera crew covered Governor Wallace at the same time.

SIMMONS' TV RESEARCH Does it give magazines an edge over TV?

Television researchers were waiting last week to find out whether their medium had been hurt by W. R. Simmons and Associates Research Inc.'s new television audience report.

They feared TV might suffer in the report's analyses of magazine and television audiences, but they couldn't tell immediately because the report was just going into distribution.

Moreover, such TV sources as the three networks and the Television Bureau of Advertising had not subscribed to the report, and Simmons authorities said it was going to sub-

scribers only. Nonsubscribers would have to wait and crib a look from a friendly buyer.

W. R. Simmons, president of the research organization, issued a statement which seemed to allay and arouse TV fears at the same time. It said the figures couldn't be used to compare the effectiveness of magazines and television, but it also offered a finding that seemed to give a distinct edge to magazines. The statement:

"The inclusion of television viewing information in the same study which provides audience information for 37 magazines makes possible certain joint analyses of the two media. Whereas in presenting these findings there is no assumption or implication that exposure to the two media affords equivalent opportunity for advertisers' messages to be perceived, nonetheless advertisers wish to know the numbers and types of people reached by the two media separately and in combination.

"A striking result of the study is found in the comparison of 'heavy' magazine readers who are 'light' television viewers, with the 'heavy' television viewers who are 'light' magazine readers. We find significant differences between these two groups. Proportionately more people in the former group are younger, have high social position, more education, higher household income and better occupations."

A number of TV researchers have speculated that television would suffer in "comparison" with magazines because, they contend, the two are not comparable by standard measurements.

Simmons officials said that in addition to citing readership and viewing "relationships" the study reports total program audiences for 77 nighttime network TV programs and describes the audiences in terms of age, sex, index of social position, education, household income, occupation and locality type.

TV viewing and magazine readership relationships are shown according to (1) the number of magazines read by the number of half-hour segments of TV viewed on an average evening, and (2) the average-issue audiences of 3 magazines by number of half-hour segments of television viewed on an average evening.

Also in advertising . . .

Arstark moves - L. D. Arstark & Co advertising, marketing research and public relations firm, has moved to 47 Madison Avenue, New York 22. The move consolidates the company's present locations at 375 Park Avenue and 441 Lexington Avenue.

MJ&A moves - The Chicago office of MacManus, John & Adams move Wednesday (Aug. 7) to the Apollo Building, 430 North Michigan Avenue. Phone: 467-4200.

BROADCAST TIME SALES EXPANDS

To open 17 independently-owned branch offices

Broadcast Time Sales, a radio station representative firm for the past decade, is announcing today (Aug. 5) plans to open 17 independently-owned and operated branch offices (CLOSED CIRCUIT, July 29).

Called by BTS President Carl L. Schuele "one of the most revolutionary advances in the history of station representation," the plan will grant regional franchises with rights to advertising sales and station solicitation in the territories as well as stock in the parent company to the branch office manager.

The office managers will receive training in management, station operation, and sales management, and will work on a 100% commission basis. By

offering voting stock in the parent company, plus equity in the branch office, BTS is hopeful that the branch-office system will intensify its regional operation with what Mr. Schuele calls "lower income nationally, but the finest personnel in history."

BTS plans a central billing system plus a continuous campaign of direct client calls at company headquarters across the country. In some instances BTS will create sample radio campaigns.

The new program is designed to enable the station to receive both national and regional service from one representative, and with the expansion, Mr. Schuele said BTS would become the country's largest.



Why KBTV Bought Volumes 3,4 and 5 of Seven Arts' "Films of the 50's"

Says John C. Mullins: President and owner of KBTV, Denver, Colorado

"There is no sure thing as far as television programming is concerned, but there is

**no better insurance
for good station ratings**

than Seven Arts' 'Films of the 50's'!

"With the 134 Warner Bros. and 20th Century-Fox features we have recently acquired we are looking forward to dominating feature film programming in Denver for the next three years.

"For example, we had ARB do a coincidental for our *prime time* debut of 'Mr. Roberts' on January 19 from 9:00-11:00 P.M. We scored an Average Rating of 32 with a 65% Share-of-Audience! How's that for insurance?"



A SUBSIDIARY OF SEVEN ARTS PRODUCTIONS, LTD.
NEW YORK: 200 Park Avenue 972-7777
CHICAGO: 4630 Estes, Lincolnwood, Ill. ORchard 4-5105
DALLAS: 5641 Charleston Drive ADams 9-2855
LOS ANGELES: 3562 Royal Woods Drive, Sherman Oaks, Calif. STate 8-8276
TORONTO, ONTARIO: 11 Adelaide St. West EMpire 4-7193

For list of TV stations programming Seven Arts' "Films of the 50's" see Third Cover SRDS (Spot TV Rates and Data)

NAACP DEMANDS HIT SNAG

2 IATSE unions turn down requisite of adding a Negro to each crew; call it 'featherbedding'

Demands of the National Association for the Advancement of Colored People that the craft unions working in the Hollywood motion picture studios add a Negro to each crew have been flatly rejected by two unions. Despite the recommendation of George Flaherty, international vice president of the International Alliance of Theatrical & Stage Employees, that the 22 IATSE locals ratify the NAACP proposal, Scenic Artists Local 816 and International Photographers Local 659 strongly opposed it at membership meetings last week.

The Scenic Artists members, at their meeting, adopted a statement of policy drafted by the local's board which expressed "sympathy for the aims and purpose of the NAACP," but continued: "this union takes a position that the request. . . to force the employment of a Negro in addition to the normal regular crew would constitute featherbedding which we are opposed to in principle as being immoral if not illegal and will not be a party to such an act."

The resolution also noted that the "deterioration of the motion picture industry in Hollywood has resulted in the lack of employment opportunities," which makes compliance with the NAACP demands "impossible at this time." The statement concluded: "This

local union does once more reaffirm that section of the obligation that we all took upon becoming a member of the IATSE, which states: 'we will use every honorable means to secure employment for the members of this union in preference to nonmembers.'"

A telephone check made by BROADCASTING revealed that the proposal for providing employment for Negroes on the basis of the population distribution ratio of one Negro for every nine white workers, was to have been taken up at yesterday's (Aug. 4) membership meeting of the Motion Picture Studio Grips Local 80. The Publicists Association Local 818 will discuss the subject at its meeting tomorrow (Aug. 6) and on that same date it will also be considered by the board of the Make-up Artists & Hair Stylists Local 706.

The board of the Motion Picture Costumers Local 705 will consider the matter Aug. 15; the Motion Picture Studio Electrical Technicians Local 728 board will take it up on Aug. 28; the Film Technicians Local 683 will deal with it at their next regular meeting, Sept. 7, and the Script Supervisors Local 871 on Sept. 16. Other locals have not yet set dates for their next meetings.

Talent Is Requisite ■ Some locals, like 839, the Motion Picture Screen Cartoonists, have not called meetings on

integration because they are not needed. Larry Kilty, business representative of the MPSC local, said that there is no discrimination there, "if you have talent, you're welcome," he said. "We have more minorities on our list now than you can name." Lloyd Ritchie, business representative of the Publicists Association, pointed out that his group has one Negro who has been a member for years and the application of another is being processed.

The cartoonists and publicists, however, resemble the writers, actors and directors, whose guilds have traditionally taken into their membership anyone hired by a producer, more than do the stage hands, property men, carpenters, electricians and other skilled workers whose unions have operated through the years with limited memberships and rigid seniority regulations.

The obligation cited by the Scenic Artists local in its resolution to secure employment for its members in preference to all nonmembers is still paramount with the craft unions and this is a tougher obstacle for Negroes, who are not apt to have friends as members, let alone relatives, than that of proof of ability, such as applies in the so-called creative fields.

Keeping In Touch ■ On Wednesday (July 31), representatives of the NAACP met with those of the guilds and producing organizations to tackle the problems of giving a fair break to Negro performers in casting and to present Negroes to the public as they actually are in today's society and not in

Networks plan civil rights specials

All three television networks busied themselves with civil rights programing matters last week.

NBC-TV and CBS-TV revealed plans for special broadcasts on the subject, and ABC-TV disclosed the first topic for its previously announced five-part series on civil rights.

NBC-TV will pre-empt three hours of its prime-time programing Monday, Sept. 2 (7:30-10:30 p.m.) for what it calls a "definitive study of all aspects of the civil rights issue." The network said last week that it would try to sell the entire show to one sponsor.

Pre-empted shows will be *Monday Night at the Movies*, *The Art Linkletter Show*, and *David Brinkley's Journal* with a total of 12 sponsors involved in the three shows.

Described as a "comprehensive

examination of the history of the civil rights movement from the Emancipation Proclamation down to the present day," the show will draw upon NBC's full staff of domestic correspondents for analyses, and also will call upon foreign correspondents to report on reaction to the issue in other countries.

CBS-TV on Aug. 21 (7:30-8:30 p.m. EDT) will carry a special broadcast on *The Press and the Race Issue*, examining charges and countercharges concerning the manner in which the press and broadcast media have handled the race issue.

CBS News's Charles Collingwood will be the reporter on the program, which will include a discussion moderated by Edward Barrett, dean of the Graduate School of Journalism at Columbia University, with James Kilpatrick Jr., editor of the *Rich-*

mond (Va.) News-Leader, Grover Hall Jr., editor of the *Montgomery (Ala.) Advertiser*, and Richard S. Salant, president of CBS News.

Also last week, ABC-TV disclosed that Governors George Wallace of Alabama and Orville Faubus of Arkansas, as well as the Rev. Martin Luther King and *Atlanta Constitution* publisher Ralph McGill will be among those who will appear on the first of its five *Crucial Summer: The 1963 Civil Rights Issue* programs, scheduled to be aired Aug. 11 (10:30-11 p.m. EDT).

The program, titled "Chronology of Crisis," will review the major events of the civil rights story in this country—especially since the end of World War II. The subsequent four programs of the series will be presented each Sunday night at 10:30 p.m. EDT through Sept. 8.

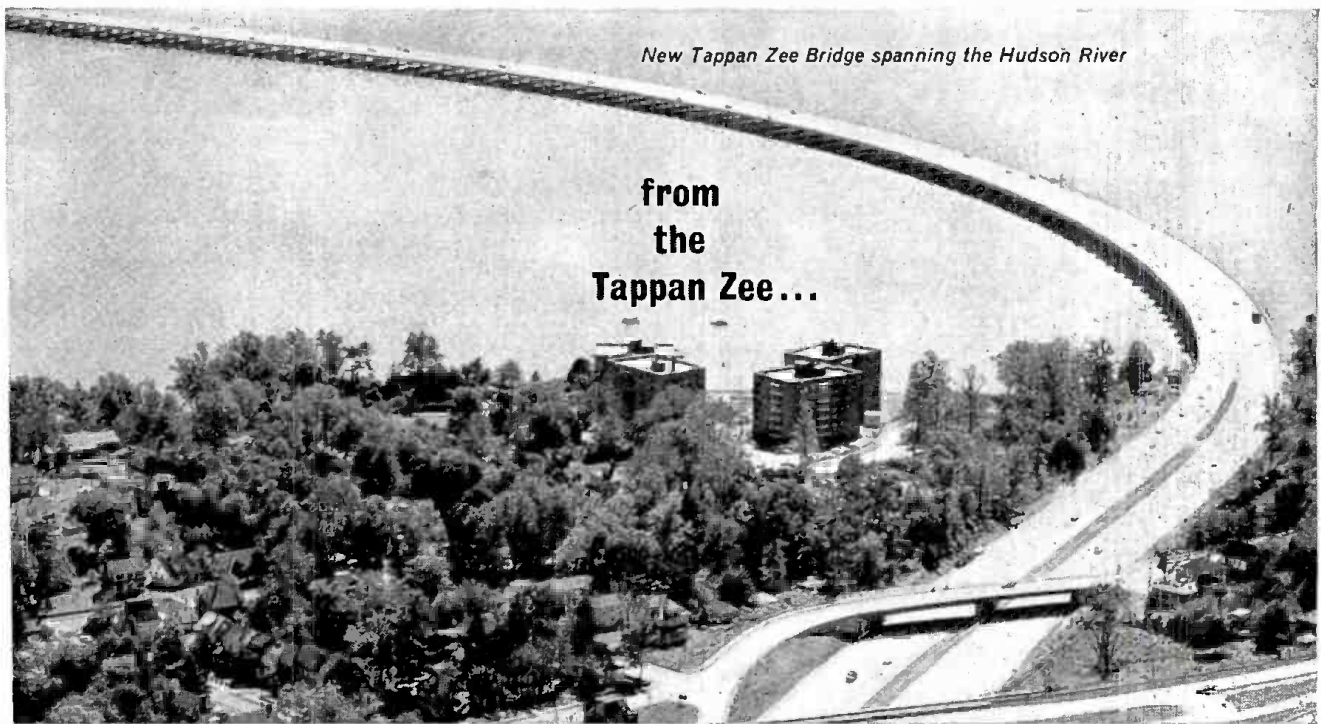

New Tappan Zee Bridge spanning the Hudson River

**from
the
Tappan Zee...**

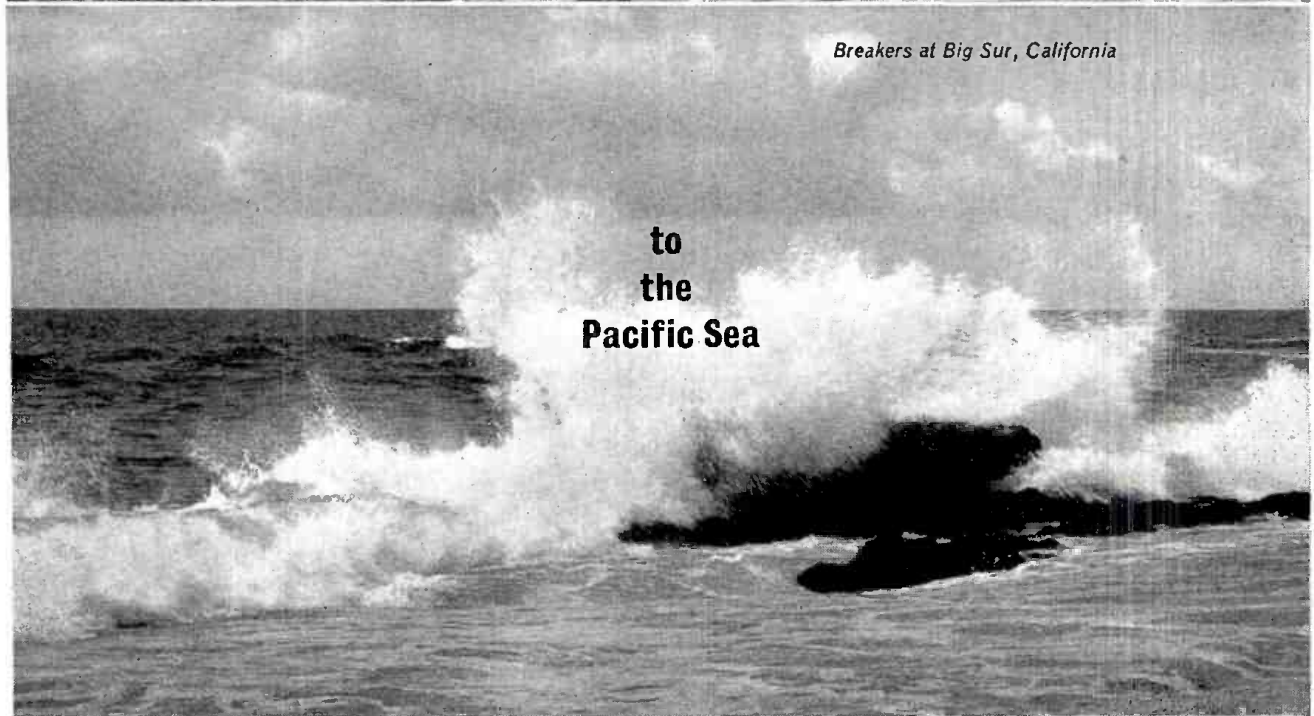

Breakers at Big Sur, California

**to
the
Pacific Sea**

**WGN Radio reaches the largest audience of
any broadcast property west of the Hudson***

WGN IS CHICAGO



**NCS, 1961*

**ANOTHER VALUABLE
ADVERTISING
OPPORTUNITY
ON **WNBC-TV**
NEW YORK**



**Deliver greater reach
of unduplicated
homes and greater
cost efficiency than
across-the-board
spot schedules.**

HERE'S HOW THEY WORK

YOU BUY a fixed schedule of four 20-second prime-time announcements in four weeks each one in a different time.

YOU GET good average weekly ratings

PLUS a four-week cumulative rating which will give you an excellent cost-per-thousand for a wide audience.

**IT GIVES YOU MORE FOR
YOUR TELEVISION DOLLAR**

Ask your WNBC-TV or NBC Spot Sales Representative for complete details.

WNBC-TV **4 NEW YORK**

CBS-TV policy paper on use of Negroes

The importance of employing Negroes in television programs was stressed last week in policy statements circulated among producers and performers.

Michael H. Dann, vice president in charge of programing for CBS-TV, sent a memo to staff producers and outside packagers re-emphasizing the network's position that Negroes be "adequately and accurately" depicted in programs appearing on CBS-TV.

Mr. Dann noted there are "many Negro doctors, lawyers, school teachers, engineers, policemen, nurses, and jurymen in life today," and said CBS-TV "wished to maintain realism about having them appear as such

in our dramatic programs."

The New York chapter of the National Academy of Television Arts and Sciences issued a statement of policy to its membership to "remind the TV industry of its responsibility to reflect the realities of the American scene by employing and truthfully representing all facets of our population."

The statement said that "this applies especially to the Negro. There are in America Negro ambassadors, Negro judges, Negro doctors and Negro lawyers as well as Negro housewives and workers. There is no reason why television should not take pride in this fact and reflect this pride in the casting of its programs."

the old stereotyped manner. The more than 20 executives in attendance organized themselves into a permanent guild-management committee which will maintain liaison with the NAACP.

Participating in the discussion were James L. Tolbert, president of the Beverly Hills-Hollywood branch of the NAACP, and Morris T. Johnson, NAACP attorney. The Screen Actors Guild was represented by George Chandler, president; John L. Dales, national executive secretary; Charlton Heston, vice-president; Chester Migden, attorney. Directors Guild of America: Joseph Youngerman, national executive secretary; Morris Abrams, assistant secretary; Willis Goldbeck and John Bowman, council members.

Writers Guild of America: Nate Monaster, president; Michael Franklin, executive secretary. Screen Producers Guild: Julian Blaustein. Composers and Lyricists: Georgia Hanni. Screen Extras Guild: H. O'Neill Shanks, executive secretary.

Management representatives were: Alliance of Television Film Producers: Richard Jencks, president; Anthony Frederick, Revue; Dixon Dern, Desilu. Association of Motion Picture Producers: Charles Boren, executive vice president; Alfred P. Chamie, secretary-treasurer; Maurice Benjamin, general counsel; Bonar Dyer, Saul Rittenberg and Gordon Stulberg, board members.

The NAACP has not yet made a formal approach to the broadcasters in the Los Angeles area or to the advertising agencies, although Herbert Hill, national labor secretary of the organization, had promised that agencies and advertisers would be called on to insure that Negroes get a fair break in commercials as well as in programing (BROADCASTING, July 29).

**NTA parent firm buys
L.A. fruit packager**

Mission Pak, Los Angeles, packager of California fruits, is being acquired by National General Corp., operator of 225 motion picture theaters, as part of a program of diversification. The acquisition, to be completed by Aug. 15, involves NGC's issuance of a net amount of 135,276 shares of its common stock, after adjusting for the 59,000 shares of Mission Pak and the \$340,000 worth of MP's 5% convertible debentures acquired by NGC earlier this year as an investment. NGC has formed a wholly-owned subsidiary, Mission Pak Co., to carry on and expand the 43-year old business. NGC is also owner of 38% of the stock of National Telefilm Associates, five community TV systems and other interests and is readying a nationwide closed circuit color TV theater network for operation beginning in 1964.

Stanley Pflaum Associates, Los Angeles, which has handled Mission Pak advertising since 1949, will continue as agency for the operation. Company last year spent some \$300,000 for broadcast media, divided between TV and radio on a four-to-one ratio, all spent in the six-week pre-Christmas period and largely in California, where most of the Mission Pak retail outlets are set up for the holiday sales season. The advertising is expected to be expanded after NGC's takeover.

**RADIO STATION
FORCED SALE!**

See page 79

Hamilton-Landis
G ASSOCIATES, INC.

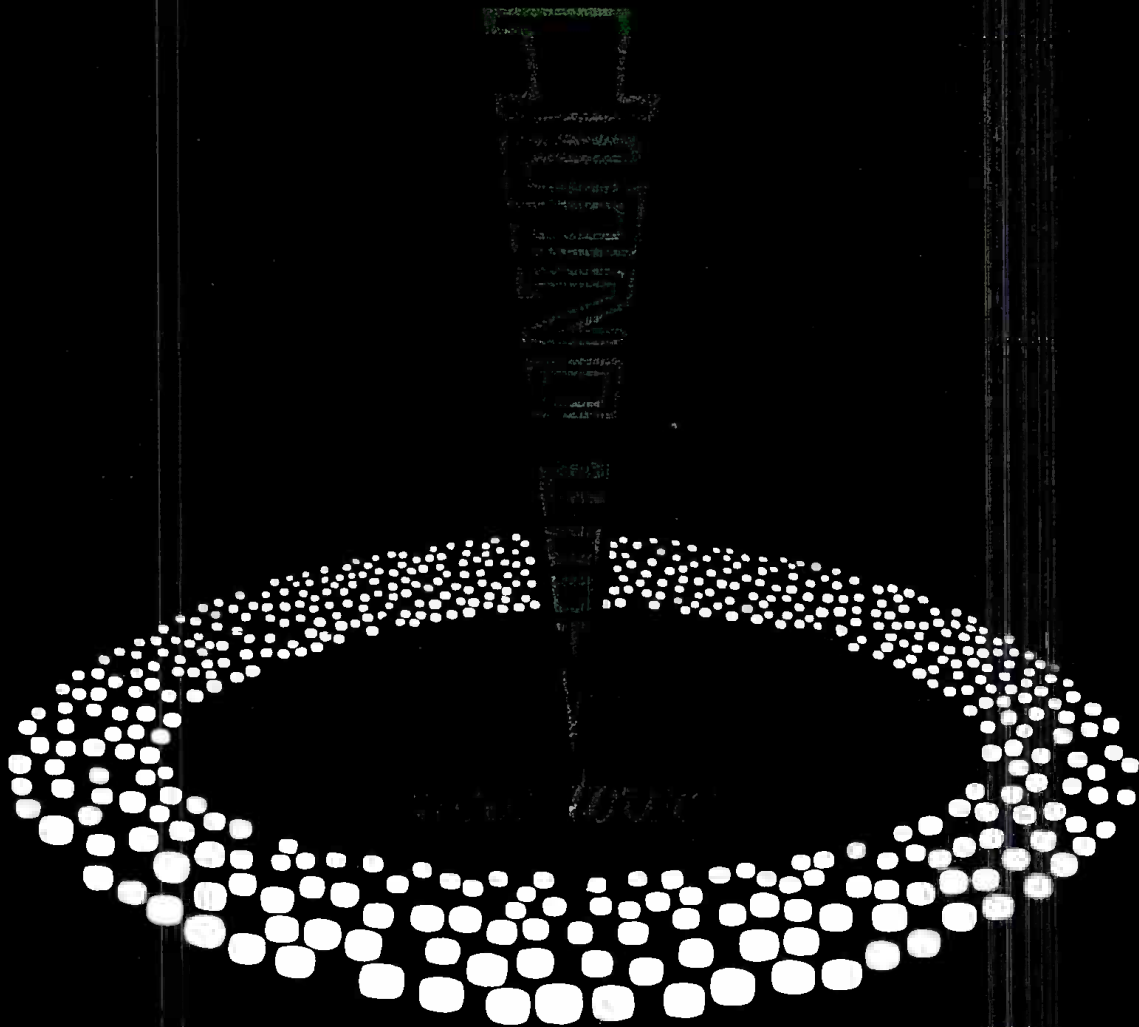

TECHNICALLY IT MEANS GREATER COVERAGE AREA THROUGH MAXIMUM TOWER HEIGHT PLUS MAXIMUM POWER. EASTERN GEORGIA'S TALLEST, MOST POWERFUL.

STATISTICALLY IT MEANS APPROXIMATELY 70,000 TELEVISION HOMES ADDED TO OUR POTENTIAL COVERAGE IN EASTERN GEORGIA AND WESTERN SOUTH CAROLINA.

PRACTICALLY IT MEANS BETTER ADVERTISING RESULTS THROUGH THE CBS FACILITY IN GEORGIA'S SECOND MARKET.

what does it mean to advertisers?

Another TALL TOWER by KIMCO

KLINE Iron & Steel Co. P. O. Box 1013 Columbia, S. C.

wrdw-tv 12

Augusta, Georgia
Rust Craft Greeting Cards, Inc.

REPRESENTED BY ADAM-YOUNG, INC.

Editorial freedom endorsed at Athens

HARRIS OPPOSES LEGISLATION, PREDICTS NONE WILL PASS THIS YEAR

Many problems remain unsolved in the field of broadcast editorials but few, if any, escaped discussion at the first National Broadcast Editorial Conference in Athens, Ga., July 25-27.

There was near unanimity among the 130-plus registrants and panelists that FCC strictures on radio and TV as advocates have been inimical to the public interest. And, conference participants agreed, the primary responsibility for fairness in editorializing rests with the licensees and should not be legislated by Congress or placed in rules by the FCC.

A powerful voice in Congress agreed with the latter view. Representative Oren Harris (D-Ark.) told the conference that broadcasters themselves should develop guidelines for editorials. The chairman of the House Commerce Committee, in a departure from the prepared text of a July 26 speech (BROADCASTING, July 29), predicted that restrictive legislation on broadcast edi-

torials will not pass during this session of Congress.

At the same time, Representative Harris stressed that members of Congress are greatly concerned over political editorials and the power they can wield. Criticism of congressional hearings on broadcast editorials (BROADCASTING, July 22) was put forth during almost every session of the conference and Representative Harris's defense of the inquiry did little to relieve the apprehension of broadcasters.

The conference, sponsored by the Georgia Association of Broadcasters and the Henry W. Grady School of Journalism, University of Georgia, took two firm steps. Conference participants adopted resolutions:

▪ Agreeing that an annual conference would be held on broadcast editorials "with sponsorship provided by those state associations of broadcasters, radio and TV stations and institutions of higher learning which desire" to aid

future conferences.

▪ Declaring that "ambiguous interpretations" of the fairness doctrine by the FCC have hurt the public interest and that legislation "can only inhibit the art of broadcast editorializing." Broadcasters, the resolution continued, "can best solve the problems developed by the relatively new art of broadcast editorializing only through the conscientious evolving of policies, techniques and procedures. . . . We firmly believe evolution unfettered by restrictive legislation and guided by responsible broadcast editorialists can supply [the answer]. The members of this conference pledge ourselves to this end."

Dick Mendenhall, WSB-AM-TV Atlanta editorial director and chairman of the Athens conference, reappointed his steering committee and added four other members to plan the 1964 session. A meeting of this committee will be held in Washington Aug. 22, at which time a new chairman will be named and

'Anyone read the First Amendment lately?'

"What the hell is going on in this country?"

Asking that, an alarm was sounded Thursday in Chicago by the Radio-Television News Directors Association's past president over the growing trend toward government control of broadcasting. Particularly singled out: the congressional probe of station editorializing.

Dick Cheverton, past president of RTNDA and news director of WOOD-AM-TV Grand Rapids, Mich., told a new Chicago chapter of the association that radio and TV newsmen had better start asking themselves this frank question "or be satisfied to work in a profession that is a mockery of the constitutional order."

Also asking if anyone has read the First Amendment lately, Mr. Cheverton called for newsmen to "quit being tolerant" of these incursions and to "make their stand now. We ought to label this congressional interference with the establishment of free journalism for what it is: a dangerous experiment that has no place in America."

Mr. Cheverton observed that Representative Walter Rogers (D-Tex.) called his probe of radio-TV editorializing because 20 congressmen

"complained that the stations were violating the rules of fair play in their editorials." The news official asked whether Congress would dare call a probe of a new religious group just because 20 congressmen didn't like another religion moving in on their churches.



Mr. Cheverton

Hands Off ▪ "They'd be jeered out of office," Mr. Cheverton said, pointing out that the First Amendment "orders" Congress to "keep its hands off" both religion and the press. And the founding fathers never intended to exclude new communication innovations from the "press" concept either, he explained.

As for the concern of congressmen over "fair play," Mr. Cheverton noted that "the Congress imposed a rule on broadcasters which allows only politicians—not lawyers, not doctors, not clergymen, not truck drivers—but politicians and only politicians equal time on radio and TV to answer any comments about them."

Citing Representative Rogers's view that the broadcasters who editorialize must have clearer guidelines for their own protection, Mr. Cheverton said that "any time Congress imposes guidelines, they are controlling. Rogers's statement about 'protection' makes me uncomfortable. Congress doesn't have to protect journalism. The First Amendment has already taken care of that."

Mr. Cheverton also had a question for Representative Robert W. Hemphill (D-S. C.), who he said

possible 1964 sites discussed.

FCC and Fairness ■ FCC Commissioner Kenneth A. Cox participated in a panel on "Management-Government Relations" but he did not mention, until questioned, the commission's policy statement the same day (July 26) on the fairness doctrine and controversial issues (BROADCASTING, July 29). He maintained the statement contains nothing new" and is simply an effort on the part of the FCC to remind licensees of guides "which we have reason to believe some people have been overlooking and to caution them about their observance."

At that time none of the conference participants had seen the statement and Commissioner Cox was not questioned further.

The FCC member and Washington attorney W. Theodore Pierson of Pierson, Ball & Dowd clashed over "limitations" FCC has placed on broadcast editorials. Panel moderator Dick Cheverton, news director of WOOD-AM-TV Grand Rapids, Mich., opened the discussion with the contention that continued regulation can only become more complex. It is confusing to work under a broad principle that changes as the FCC and Congress change, he said. "This is the



Representative Oren Harris (D-Ark.) (l), principal speaker at the National Broadcast Editorial Conference in Athens, Ga., commends NBEC Chairman Dick Mendenhall, editorial director of WSB-AM-TV Atlanta, on the de-

dilemma faced by management and those of us who editorialize."

The industry is better off with guide-

lines set down by the FCC, Commissioner Cox maintained in pointing out that stations are licensed and newspapers are not. Broadcasters would only encourage restrictive legislation if they went before Congress "asserting the absolute, untrammled right to do exactly as newspapers do—to be unfair, to be unequal," he said.

Mr. Pierson said that FCC policies have relegated the broadcaster to serve in the role of a moderator, not as an advocate. History demonstrates that government is fickle and often motivated by purely partisan considerations, he charged. The FCC's present broad standards to protect the public interest are "the worst possible way to regulate," Mr. Pierson said.

If a fairness doctrine is necessary, it should be administered by the courts and not the FCC, the Washington counsel maintained. Under the present setup, he said, the "great evil" is not affirmative steps taken by the commission but the licensee's great fear that he "must please every capricious whim of the licenser."

Great Danger ■ In a later interview with George Patton, WBML Macon, Ga., Mr. Pierson said the FCC should be "confined in its coercing of licensees." He told WBML that fickleness on the part of the FCC demonstrates the "great danger in setting up broad standards and then giving to a nonjudicial agency the right to promulgate rules." Where the government must interfere with broadcasting, he said, it should be done through the judiciary to delete any political influence.

Commissioner Cox defended the actions of the FCC in the areas of public

appears to feel broadcasters are becoming increasingly abusive of their editorializing "privilege." The RTNDA spokesman asked, "Since when is the dissemination of opinion in this country a privilege? It can't be, unless Congressman Hemphill does not believe in the 'free press' guarantee."

Mr. Cheverton said he would like to point out to Representative Hemphill that editorializing—"the so-called abuse"—was a powerful weapon in the hands of men like John Adams and Tom Paine in affecting the very government which sustains Representative Hemphill. The Declaration of Independence is an editorial. Does Representative Hemphill think, as the British did, that it was an abuse?"

Double Standard ■ Mr. Cheverton said the congressman obviously doesn't "but his language emphasizes a double standard that is being accepted in this country. No one attacks journalistic effort if it is carried on newspapers.

"But what happens if a newspaper and a broadcast station carry the same editorial in one of those congressional districts where a representative thinks he's been abused? Is the newspaper editorial an abuse

of 'privilege' to be debated in Congress?" Mr. Cheverton asked. "Or is it excluded because newspapers are not licensed by the government?"

Mr. Cheverton explained that what is really being said "is that radio news, as part of a radio station, is under government control. Representative Glenn Cunningham [R-Neb.] put it bluntly when he said, 'Editorials ought to be sanctioned by Congress, not by some bureaucrat downtown.'"

Comparing such views with the language of the First Amendment, Mr. Cheverton said, "What do you think now of freedom of the press?"

The new local chapter of RTNDA was organized during a luncheon meeting held in the executive dining room at WKBK(TV) Chicago. Additional chapters are to be organized in other cities, it was said. Harold Salzman, WLS Chicago, was made temporary chairman of the Chicago group.

The new chapter also voted a resolution that the RTNDA annual meeting in Minneapolis Sept. 11-14 should discuss and "take urgent and concerted opposition to FCC public notice 38372 which concerns the stations' responsibilities under the fairness doctrine."

interest, fairness doctrine, controversial issues and editorials. He said the FCC has had no difficulty separating its administrative and enforcement functions and that, if Mr. Pierson's suggestions were followed, broadcasters would forever be bogged down in court without a decision on what they could or could not do.

This particularly would be true on Section 315 (equal time) questions, the commissioner said, in pointing to the speed with which the FCC acts in this area.

There is no evidence, he countered, that the FCC has restrained or coerced broadcasters. "The FCC's standards were not set at a cost to editorial freedoms nor have they hurt the public," the commissioner contended. Competition, he said, will not solve the problem of fairness and standards must be applied to the multi-station as well as the one-station market.

Commissioner Cox said the FCC does plan to issue a primer of do's and don'ts on editorials.

No Quarrel ■ Another panelist, Willard Schroeder, general manager of WOOD-AM-TV, said that he could not argue with the FCC's fairness doctrine as expressed in the 1949 policy statement on editorializing. Trouble arises, he said, when the FCC attempts to specify what should or should not be done in a given situation. He questioned the value of an FCC primer on editorials, similar to the present one on political broadcasting because broadcasters are more confused on Section 315 because of the existing primer.

Kurt Borchardt, communications counsel for the House Commerce Committee, said there is little reason for broadcasters to fear that Congress will take away their right to editorialize. He pointed out that only one member of the committee, Representative John Bennett (R-Mich.), has expressed a view that stations are not authorized by the Communications Act to editorialize and that no other committee members have agreed with him.

Mr. Borchardt agreed with his boss, Representative Harris, that legislation which would restrict broadcast editorials is not likely.

Most broadcasters agreed during a July 27 panel on political editorials that stations should endorse candidates for public office—but only after thorough investigation of the candidates and issues.

An earlier panel stressed the importance of thorough research before editorials are undertaken on any subject. The participants agreed that the size of a station's staff is not important in a decision to editorialize but that the staff must be competent.

Representative Harris and Mr. Borchardt made appeals for editorialists to

Color for country music

One of broadcasting's pioneer programs, *The Old Time Fiddlers* which started on WLS Chicago in 1924 and later became known as the *National Barn Dance* for 36 years, will go on television in color this fall when it starts on WGN-TV Chicago. WGN radio has broadcast a continuation of the show as *The WGN Barn Dance* since early 1961. The new Saturday evening colorcast on WGN-TV is scheduled to begin next month with date and specific time to be set.

WGN-TV, the Chicago Tribune station, which telecast 1,700 hours of color in 1962, presently is running in color at an annual rate of 2,200 hours and may hit 2,400 hours by the year's end.

appear before the Communications Subcommittee of the House Commerce Committee when it resumes hearings later this month on broadcast editorials. "Come and speak as individuals," Mr. Borchardt urged.

More than a half-dozen of the broadcasters at the conference said they would request an opportunity to testify. None of them had planned to appear prior to the conference.

Future Plans ■ "Reason and responsibility are the only guides we need" in future editorials, Dale Clark, WAGA-TV Atlanta, said in a summation of the conference. Editorials must follow a course of reason and broadcasters do not need a lawyer or the FCC to tell them what is fair and right, he said.

Members of the 1964 committee, in addition to Mr. Mendenhall, include Messrs. Cheverton and Clark; Professor Worth McDougald, head of the radio-TV department, University of Georgia; Ralph Renick, WTVJ (TV) Miami; Bryon Cowan, WSAC Fort Knox, Ky. (all members of the 1963 NBEC committee); Roger Turner, WMCA New York; John Corporon, WDSU-TV New Orleans, Jack Williams, executive secretary, GAB, and Bill Monroe, NBC News, Washington.

In addition to the above, Mr. Mendenhall said that Ed Ryan, news director of WTOP-TV Washington, and a representative of the National Association of Broadcasters, would be invited to attend the Washington meeting.

Raymond Carow, WALB-TV Albany, Ga., and president of the GAB, indicated unofficially that the Georgia broadcasters again would like to sponsor the conference in 1964. The same sentiment was expressed by Professor McDougald. The conference, held in the Center for Continuing Education on

the university campus, attracted twice as many participants as the sponsors had originally planned.

In the resolution adopted by the conference, NBEC was established on an annual basis open to all radio and TV stations.

In a second resolution, the NBEC delegates described the conference as a "major positive effort to attain increasing maturity in broadcast editorializing. . . . All concerned in the complexities of broadcast editorializing are seeking fairness. We submit that the so-called fairness doctrine as ambiguously interpreted and defined by the FCC and individual congressmen is not the totally fair approach. Nor is it in the fullest sense in the complete public interest, convenience and necessity."

Will it some day be AP, UPI—and NBC?

NBC News announced the opening of new wire service today (Aug. 5) linking its New York and Washington communications centers and making reports from its correspondents all over the world readily available in "item form" to all the network's news units.

William R. McAndrew, executive vice president in charge of NBC News, said the new service would not replace any regular wire service used by the network but would only be used to carry NBC's own news coverage.

He referred to the new link as a natural outgrowth of increased numbers of NBC News shows and an expanded network news staff. Mr. McAndrew noted that with the change, NBC News correspondents will function as wire service reporters as well as broadcasters, phoning and cabling stories when other circuits are unavailable and adding detail and color to stories carried by the regular news services.

He called the new circuit "the first leg of an NBC News wire service" and added that it could "develop into a much more comprehensive one . . . and might be made available outside NBC."

Unexpected news special

A WXYZ-TV Detroit telecast of a golf tournament was transformed from a routine show into a live news special July 27 when a golf course bridge holding 80 spectators suddenly collapsed into a river just one minute before air time.

As the "Womens' Wolverine Open" tournament was canceled for the day, WXYZ-TV turned its cameras to the disaster area for an hour's worth of live news, including interviews with some of the injured spectators. The coverage was video-taped and 30 minutes of highlights were replayed later in the day.

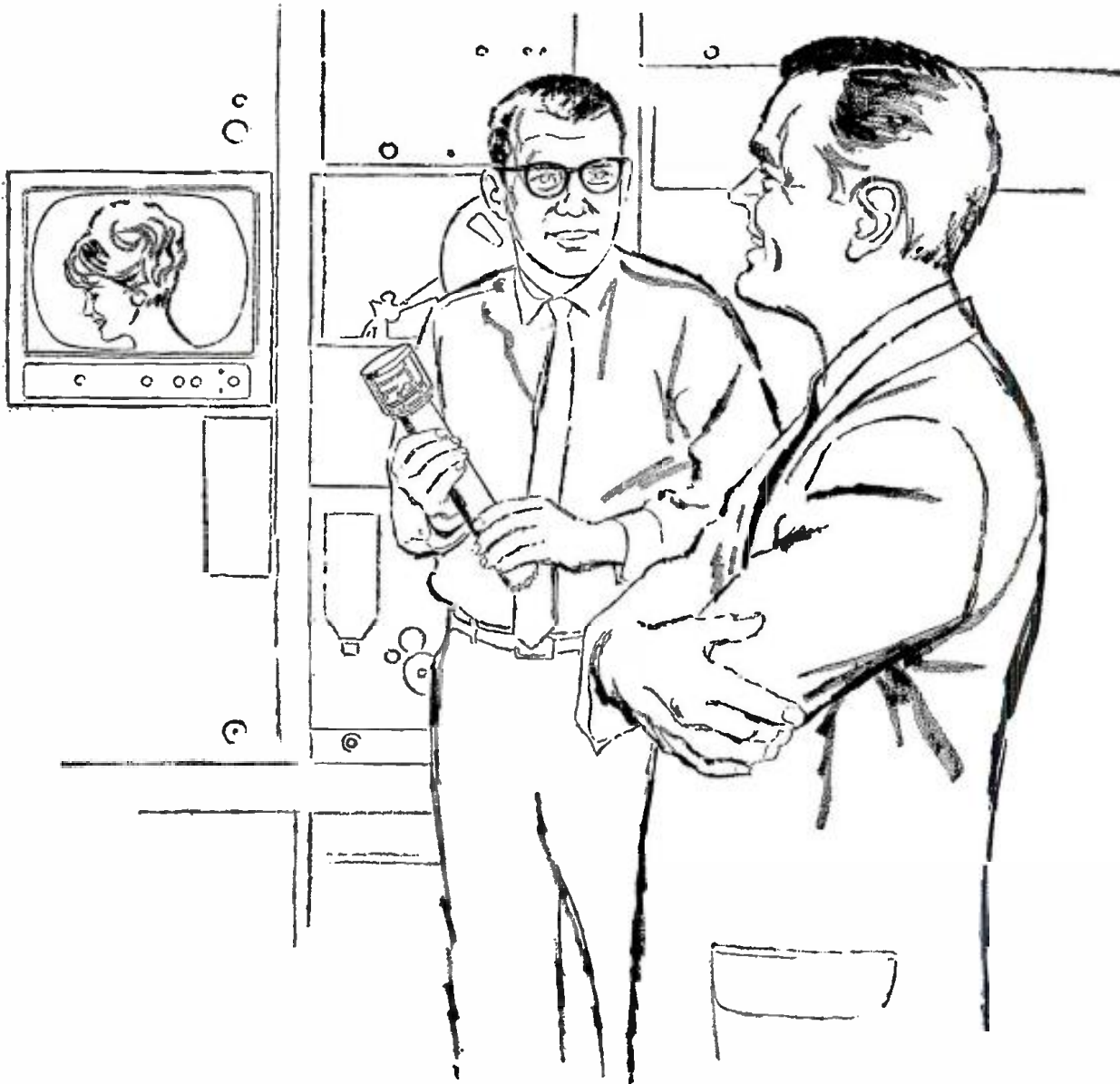

Sponsor Preferred

Choose RCA-4415 & 4416 for Your Big Year in Color

Colorcast schedules are growing heavier. And heavier. And heavier. Get set now to deliver the sharp, true, bright pictures sponsors demand for their programs and commercials. Replace with RCA Image Orthicons 4415 & 4416. For RCA insists on highest quality performance in its color image orthicons. And has invested more to get it.

The RCA 3-tube factory-matched set in your camera produces exceptional pictures in color receivers, as well as high resolution pictures with normal tone rendition in black-and-white sets...at lighting levels available in black-and-white studios! There's no problem of high scene-lighting temperatures...no need for extra air-conditioning. And

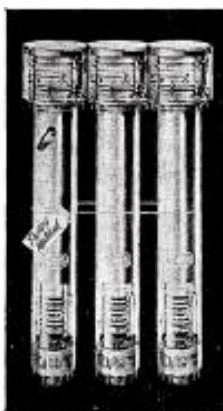

many lighting costs usually associated with high-quality indoor color pickup are avoided.

RCA precision construction, Field Mesh, plus finely matched tube characteristics assure you excellent picture registration and uniform color balance over the entire scanned area.

Also available is RCA-7513, an Image Orthicon for highest quality color pickup using conventional color TV lighting. Ask about RCA Image Orthicons locally. SEE YOUR AUTHORIZED DISTRIBUTOR OF RCA BROADCAST TUBES.

RCA ELECTRONIC COMPONENTS AND DEVICES, HARRISON, N. J.



The Most Trusted Name in Television

For name and address of your local distributor write or call your nearest RCA Distributor Products Sales Office—New York, N. Y.: 36 W. 49th St., MUrray Hill 9-7200; Needham Heights 94, Mass.: 80 "A" St., Hillcrest 4-8480; Washington 7, D. C.: 1725 "K" St., S.W., Federal 7-8500; Atlanta, Ga.: 134 Peachtree St., N.W., JACkson 4-7703; Cleveland, Ohio: 1621 Euclid Ave., CHerry J-3450; Chicago, Ill.: Merchandise Mart, 467-5900; Dallas 7, Texas: 7901 Carpenter Freeway, MELrose 1-3050; Kansas City 14, Mo.: 7711 State Line, EMerson 1-6462; Los Angeles 22, Cal.: 6801 E. Washington Blvd., RAYmond 3-8361.

O'NEIL, WRIGHT HAPPY IN HARTFORD

First year of pay TV test considered successful

"Encouraging and enlightening" was the description of subscription television's first-year test over WHCT(TV) Hartford, Conn., given last week by Thomas F. O'Neil, chairman of the board of the General Tire & Rubber Co., parent firm owning WHCT. The pay TV project is being conducted by a General Tire subsidiary, RKO General Phonevision Co.

Mr. O'Neil's first-year report was issued in association with Joseph S. Wright, president of Zenith Radio Corp., developer of the pay TV system and maker of the technical equipment. The pay TV test runs for three years under FCC authority.

Mr. O'Neil said "it is still too early" for the test to provide complete con-

clusions as to the future prospects for pay TV, but "the experiment has already shown that we are meeting a public need, that program expenditures are consistent and that disconnections due either to dissatisfaction on the part of subscribers or delinquency in payment are remarkably low."

More than 3,000 homes are Hartford pay TV subscribers, Mr. O'Neil said, and the number could be much greater had the firm chosen to increase its installation pace. Since the purpose of the test is to get information for the FCC and not numbers this has not been done, he indicated, although "applications of new subscribers have sharply increased

during the last two months." RKO General Phonevision's goal, he explained, is to maintain a large enough sample "to develop data for our own purposes and for the information of the FCC in its eventual evaluation of the entire subject of pay television."

Zenith's Mr. Wright felt the results so far have been satisfactory also. "We have always believed that TV could be more than just an advertising medium," he said. "We felt strongly that it had the capability of becoming a new economic and convenient electronic box office to distribute the type of top quality entertainment advertisers cannot afford to sponsor but which the American public nevertheless wants to see."

Zenith's convictions now are "being

translated into actual practice in Hartford," he said, "and it appears that our confidence in subscription TV was justified."

Mr. Wright said his company believes commercial TV will not lose by pay TV but eventually will benefit "through renewed interest in TV as a medium, through encouraging the establishment of new stations and stimulating the creative talents of the entertainment industry."

The report noted that theater operators "are still adamant in their attempts to place embargoes on films for subscription TV" but most major film distributors have been cooperative in the

test. The highest rating films over the past year were "What Ever Happened to Baby Jane?" with 66% of all subscriber homes and "The World of Suzie Wong" with 65%.

The Hartford project telecasts approximately 75 live sports events during the first year, the report said, including professional hockey and basketball, collegiate football and basketball and professional boxing. Last fall's Patterson-Liston fight rated 81% of all subscriber homes at \$3 each. Results of the July 22 rematch were not available.

The report disclosed that RKO General Phonevision has just completed taping a special show featuring the Limelites and has scheduled another special starring Eddie Fisher. A summer theater production, not identified, also has been completed. Other programs this past year included the Bolshoi Ballet, Kingston Trio, Gian Carlo Menotti's "The Consul," "An American Pageant of the Arts," Anton Chekhov's "A Country Scandal" and guitarist Carlos Montoya.

The report said most programs are in the \$1 and \$1.50 category and subscribers pay no minimum. After a three-month bonus period, subscribers are charged a weekly rental of 75 cents for the decoder unit which unscrambles the pay TV picture on their regular TV receiver.

Film sales . . .

Century 1 features (20th Century-Fox TV): Sold to KTAR-TV Phoenix-Mesa, Ariz.; WBAY-TV Green Bay, Wis.; KVTU(TV) Sioux City, Iowa; WLWD(TV) Dayton, Ohio and WMTW-TV Poland Spring, Me. Now sold in 45 markets.

Films of the Fifties, Volume 7 (Seven Arts Associated): Sold to WGR-TV Buffalo, N. Y.; WRGB(TV) Schenectady, N. Y.; WOOD-TV Grand Rapids, Mich.; WKTV(TV) Utica, N. Y.; KSHO-TV Las Vegas, and WQAD-TV Moline, Iowa. Now sold in 18 markets.

Films of the Fifties, Volume 1 (Seven Arts Associated): Sold to KFBB-TV Great Falls, Mont. Now sold in 140 markets.

Films of the Fifties, Volume 2 (Seven Arts Associated): Sold to KRTV(TV) Great Falls, Mont. Now sold in 115 markets.

Films of the Fifties, Volume 3 (Seven Arts Associated): Sold to KMSP-TV Minneapolis-St. Paul. Now sold in 105 markets.

Films of the Fifties, Volumes 4 & 5 (Seven Arts Associated): Sold to WTRF-TV Wheeling, W. Va.; KVIQ-TV Eureka, Calif.; KOGO-TV San Diego; WKTV(TV) Utica, N. Y.; WOW-TV Omaha, Neb. and KMBC-TV Kansas City,



Mr. Wright



Mr. O'Neil

Mo. Volume 4 now sold in 80 markets and Volume 5 in 78 markets.

Seven Arts' Special Features (Seven Arts Associated): Sold to KOGO-TV San Diego; WKTV(TV) Utica, N. Y.; KSL-TV Salt Lake City; KXLY-TV Spokane, Wash., and KOLD-TV Tucson, Ariz.

En France (Seven Arts Associated): Sold to WCPO-TV Cincinnati; KGMB-TV Honolulu; WNYS(TV) Syracuse, N. Y.; CBYT(TV) Santa Barbara, Calif. and CVIQ-TV Eureka, Calif. Now sold in 31 markets.

Laffs (Seven Arts Associated): Sold to KVIQ-TV Eureka, Calif. and KGMB-TV Honolulu.

Ann Sothorn Show (Economee): Sold to KATU(TV) Portland, Ore.; WHEN-TV Syracuse, N. Y.; KARK-TV Little Rock, Ark.; WVEC-TV Norfolk, Va.; WSAV-TV Savannah, Ga.; WFMJ-TV Youngstown, Ohio; KTAR-TV Phoenix-Mesa, Ariz.; KSWO-TV Lawton, Okla.; KCEN-TV Temple-Waco, Tex.; WTVR(TV) Richmond, Va.; WBRE-TV Wilkes-Barre-Scranton, Pa.; WISN-TV Milwaukee, Wis.; KJEO(TV) Fresno, Calif.; VBTW(TV) Florence, S. C.; WNEM-TV Bay City-Saginaw, Mich.; WSIX-TV Nashville, Tenn.; WSAZ-TV Huntington,

Prime time for Powell

A poll conducted by the Four Star Distribution Corp. on behalf of *The Dick Powell Theatre* off-network series reveals that 62.5% of its station clients plan to use the series in prime time, the company reported last week. This includes such outlets as WPIX(TV) New York, KCOP(TV) Los Angeles, KCTO-TV Denver and WHIO-TV Dayton, Ohio. Firm reports the series will pre-empt network programs in markets including Grand Rapids, Mich.; Phoenix, Ariz.; Bellingham, Wash.; Shreveport, La. and Ames, Iowa. An additional 25% of the stations will slot *Powell* on Saturday or Sunday at 11:15 p.m., according to Len Firestone, vice president and general manager of Four Star Distribution. The series has been sold in 33 markets to date.

W. Va.; WCSH-TV Portland, Me.; KCPX-TV Salt Lake City; KXLY-TV Spokane, Wash.; KPRC-TV Houston, WAGA-TV Atlanta, and WLOF-TV Orlando, Fla. Now sold in 88 markets.

Program notes . . .

Children's theater ■ Four one-hour color specials primarily for children in the first and second grades of school have been scheduled by NBC-TV for the 1963-64 season. To be presented by NBC News, they are: Sunday, Oct. 6 (6-7 p.m.), musical drama with a leading actor supported by cast of puppets; Sunday, Dec. 8 (3-4 p.m.), an illustrator and a symphony orchestra; Saturday, Feb. 15, 1964 (12-1 p.m.), three one-act plays, and Sunday, April 12, 1964 (6-7 p.m.), a modern musical fantasy.

'Presidents' for TV ■ Allied Artists Television Corp., New York, has introduced a new TV series titled *The President* for syndication. It consists of 104 five-minute segments and will deal with events in the lives of young men who were later to become presidents of the United States.

Air pollution series ■ A series of 13 half-hour documentary radio programs on air pollution titled *Hold Your Breath* is being offered commercial stations throughout the U. S. by Michigan State University's WKAR East Lansing. The series will be available Sept. 1. It was

ONLY 41 DAYS LEFT



to take advantage of this SPECIAL INTRODUCTORY OFFER of any 10 Hi-Fi SESAC® RECORDINGS LP albums in the above catalog for only \$18.95.

Broadcasters can choose from hundreds of albums featuring top recording artists.

Hurry—This offer expires Sept. 15th, 1963..For your free copy of this SESAC RECORDINGS catalog, contact:

SESAC RECORDINGS • 10 COLUMBUS CIRCLE, NEW YORK 19, N.Y. • 212-JU 6-3450

COMING SOON!

THE PERFECT PLAY



FOR THE

NEW

1963-64 SEASON

TELL
'EM
HOW . . .

Roanoke is Virginia's
NO.1 TV Market with
327,100 tv homes*

about our proven
sales ability with
more than 10 years
experience

to call Katz
for avails

tell
'em . . .



got it !

* Television Magazine

WSLS-TV 10  ROANOKE, VA.

"THERE IS NO SUBSTITUTE FOR INTEGRITY"

produced under a grant from the U. S. Public Health Service. National Association of Educational Broadcasters, Urbana, Ill., will distribute the series.

New production firm ■ Valor 9 Television Productions has been formed by Joseph J. Symanski and Maurice A. Krowitz to produce live and taped TV programs. The company is located at the Goldwyn Studios in Hollywood. Telephone: Hollywood 9-6161. Valor 9's first program, *Pro Football Illustrated*, is being prepared for September release.

Sports specials ■ NBC News will present *NBC Sports Special*, a series of 90-minute TV programs beginning Saturday, Jan. 11 (4:30-6 p.m. EST). The show, featuring Bud Palmer, will cover championship competition in a variety of sports. Chet Hagan will produce.

Lincoln Center anniversary ■ CBS-TV will commemorate the first anniversary of the opening of New York's Lincoln Center for the Performing Arts with a one-hour program of ballet and musical drama called *Lincoln Center Day* on Sunday, Sept. 22 (8-9 p.m. EDT). Robert Saudek Associates will produce the special broadcast.

Susskind's syndicator ■ National Telefilm Associates, for the sixth consecutive year, has signed to distribute newly produced episodes of David Susskind's *Open End* series. To be produced by Susskind's Talent Associates Inc., at Videotape Center, New York, the new series will stick to a "current" time element in all subject matter, according to Bernard Tabakin, NTA president.

Series on gospels ■ NBC-TV in cooperation with the National Council of Churches will present a lecture series on the four gospels of the New Testament on *Frontiers of Faith* (Sundays, 1:30-2 p.m.) in September. The new series will be part of a long-term venture dealing with "the living Bible in today's world."

UA-TV special ■ *The Yanks Are Coming*, first of the six first-run syndicated one-hour specials co-produced by United Artists Television and David H. Wolper Productions will go on the air in 45 markets in November. Liberty Mutual Insurance Co. is sponsoring the six specials in 26 cities covering 20 of the top 25 markets.

**RADIO STATION
FORCED SALE!**

See page 79

Hamilton-Landis
& ASSOCIATES, INC.

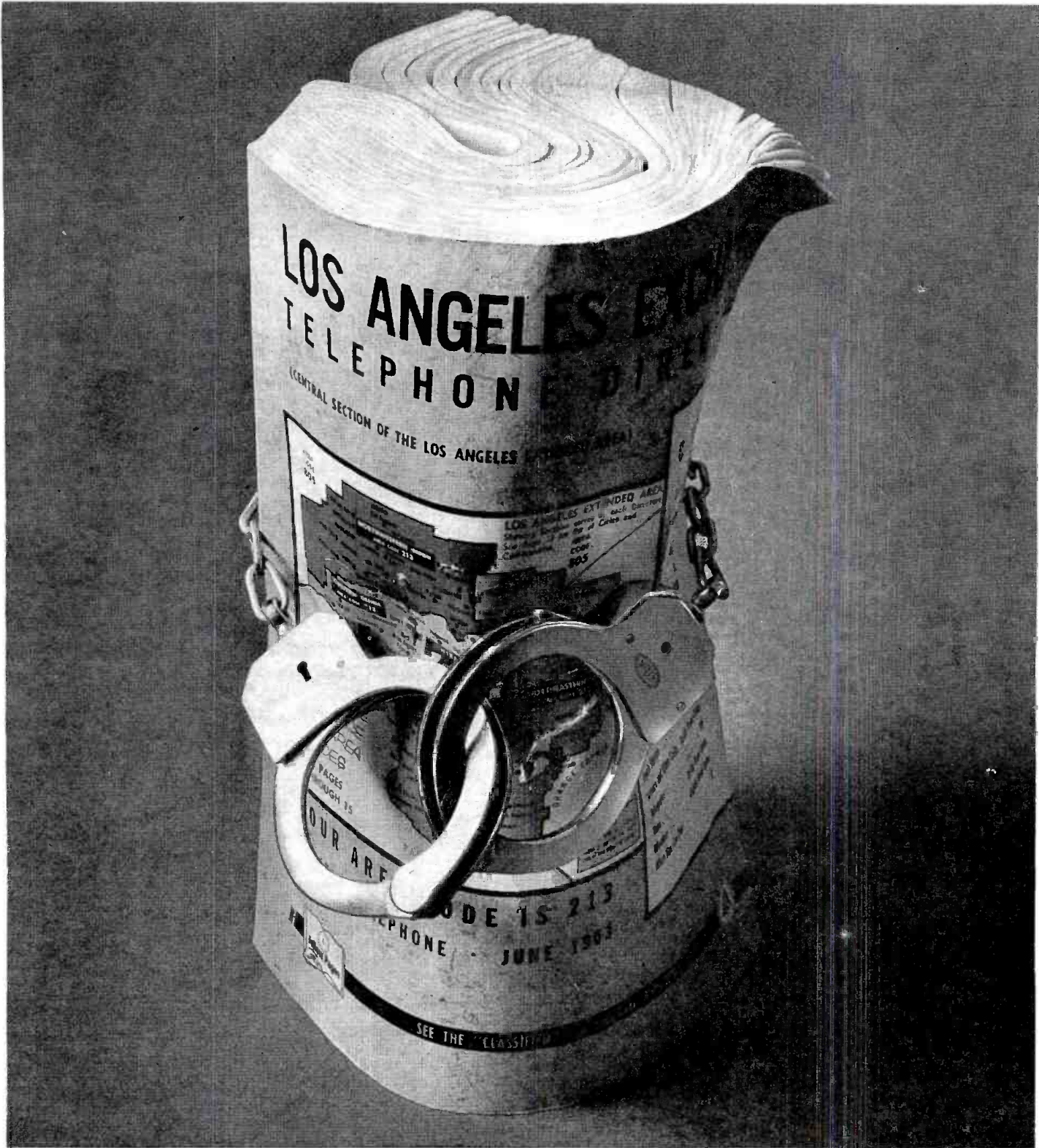

NEW BREED locks up L.A. Market!
ARB* rates NEW BREED top syndicated hour in 7-station market!

**AND
 N.S.I.
 AGREES**

PRIOR PROG. Dec. '62	NEW BREED May '63	SAT. 9:30-10:30 PM
3.2	8.3	RATING
6%	15%	SHARE OF MKT.
90,500	208,200	TOTAL HOMES

*VARIETY'S ARB'S JULY 10, 1963

The New Breed—a different kind of show about a different kind of cop. It had to be great to make these headlines. It has to be great for your station's ratings.

ABC FILMS, INC.
 1501 Broadway, N. Y. 36 • LA 4-5050
 360 N. MICHIGAN AVE., CHICAGO, ILL. / AN 3-0800
 190 N. CANON DRIVE, BEVERLY HILLS, CALIF. / NO 3-3311

How DO You snare a Gold-Crested Budgetspender?

Here is a story with a purpose:

Once upon a short time ago there was this fellow, you see, and he built up quite a reputation for himself by the way he kept capturing that most elusive of all birds, the gold-crested budgetspender. The other ornithologists (who were usually happy enough just having a lark) began to grow jealous. "How," they asked archly—his name is Fred K. Archly—"do you manage to find so many gold-crested budgetspenders?"

"Well, sir," said Fred (a quiet, courteous fellow), "I just ask myself: 'If I were a gold-crested budgetspender, where would I go?' Then I do. And they have. It's all just a simple matter of media strategy!"

Your advertising story has a purpose, too.

That's why this thinly-disguised allegory carries a message for you. There are all kinds of gold-crested budgetspenders flying around the firmament of the broadcast business. Some have bigger wingspreads than others—which makes them more desirable (albeit more elusive).

As everyone knows, a gold-crested budgetspender in the hand is worth a whole flock hidden behind a door marked "Radio-TV Department" or "General Manager" (depending which side of the street you're selling). And—at risk of scuttling Fred K. Archly's secret—you just have to know when and where you can find gold-crested budgetspenders at rest. Then you go there. And they're receptive.

The "when" is the time they happen to be in need of specific, up-to-date, indubitably accurate facts about the broadcast business. Which, in their case, is often.

The "where" is the place most of them go to find such information—a rich feeder of factual nourishment known to them (and, we hope, you) as BROADCASTING Yearbook. Like the reliable oak tree, it's a perennial mainstay that puts forth new,

fresh foliage every year. It has been doing this more and more comprehensively for the past 33 years—which is only one reason why so many gold-crested budgetspenders are attracted to its authoritative boughs . . . uh, pages. (Allegory can sometimes be tricky.)

And—would you believe it?—WE also have a purpose.

The 1964 BROADCASTING Yearbook will displace the best selling 1963 BROADCASTING Yearbook come next December 1. Every gold-crested budgetspender worth his salt will then send the old, frayed copy to his company's Reference Library, putting the bright, mint-new, bigger-than-ever edition within easy reach on his desk.

When he opens it (which could be a dozen times a day), his mind attuned to matters of budget-spending—will you be there? With your story? With the kind of facts about yourself to influence his decisions?

Fred K. Archly will. He's already sent in his space reservation for the 1964 BROADCASTING Yearbook, smart fellow. But there are quite a few other prominent, advantageous positions still open. We can't guarantee for how long. (Here is a happy case where the early bird gets something really worthwhile for his foresight.) Lots of people are interested in making profitable contact with gold-crested budgetspenders. Some of them are probably those birds of prey you call competitors.

You can read a frank appraisal of the 1964 BROADCASTING Yearbook's virtues in the column at right. The average reader will absorb all the facts in 47.3 seconds. But if you read faster, you can reserve your space that much sooner. Never put off until tomorrow what you can do TODAY—particularly when you're invited to call your nearest BROADCASTING office collect. (We also accept postage-due mail.)



Some anonymous genius (with a flair for descriptive precision) has aptly called this—

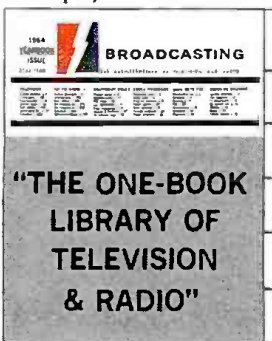

WHY? Because the 1964 BROADCASTING Yearbook is a veritable library of 50 separate directories, comprising the most complete assembly of information about the radio and TV business ever published . . . yet all compacted with editorial skill into a single, easy-to-use volume.

The 1964 BROADCASTING Yearbook (biggest yet) will have nearly 650 pages, two-thirds of a million words, all tabbed for instant reference under six main sections:

- A. Television Facilities
- B. AM/FM Radio Facilities
- C. Broadcast Equipment/FCC Rules
- D. Codes/Program Services
- E. Representatives/Networks/Trade Groups
- F. Agencies/Advertisers/Billings

In short, this unique one-book encyclopedia covers every possible background fact needed by people who work with, and in, the world of broadcasting. No other reference work even approaches the thoroughness with which it documents the radio-TV business, including associated arts and services.

Your advertisement, strategically placed in the 1964 BROADCASTING Yearbook, will keep making multiple impressions throughout the whole 12-month life of this remarkable source book. It can be one of your most successful promotional investments because it delivers your story at the very times the people who buy are most receptive.

Circulation: 20,000 copies

Publication: December 1

Rates: same as BROADCASTING Magazine.

Deadline: final date is October 1; if advance proofs are required, September 15.

Special Positions: subject to immediate space reservation. Write, wire or phone your nearest BROADCASTING advertising office (Washington, New York, Chicago or Hollywood).

Recommendation: Reserve the position you want—**TODAY**—before somebody else gets it!

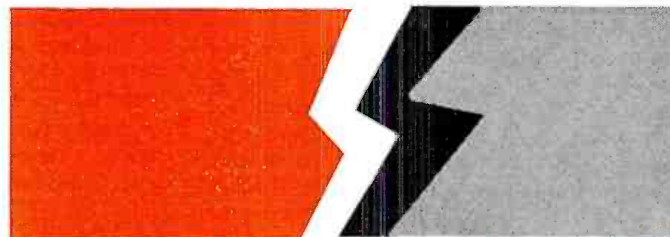

BROADCASTING YEARBOOK

1735 DeSales Street, N.W., Washington 6, D. C.

New York — Chicago — Hollywood

TELEVISION ON BROADWAY

Westinghouse, as angel, will telecast new stage play on opening night in New York

Television and Broadway will join hands in October when Westinghouse Broadcasting Co. presents a new three-act dramatic play on its five TV stations at the same time that the theatrical production opens in New York.

The play, "The Advocate" will open at the ANTA theater in New York on Sunday, Oct. 13. It will be televised on that date on Westinghouse's stations—WBZ-TV Boston, KYW-TV Cleveland, KDKA-TV Pittsburgh, WJZ-TV Baltimore and KPX(TV) San Francisco. The show will be taped for television in New York following the conclusion of its two-week tryout in Mineola, Long Island, and before its Broadway opening. Westinghouse also has TV syndication and will share in the motion picture rights.

Donald H. McGannon, president of WBC, in announcing the new venture last Thursday said that Westinghouse put up \$60,000 of the \$100,000 financing for the Broadway production. In addition the TV production itself will cost the company \$80,000.

The television show will be offered for sponsorship, but the production will not be interrupted for commercial messages, Mr. McGannon said. Commercials will be presented at the opening, during intermissions and at the closing

of the drama.

Mr. McGannon pointed out that Westinghouse does not expect to receive a profit from the original TV production on Westinghouse stations. He added, however, that the program will be offered for syndication following its initial run.

He noted that Westinghouse is "looking forward to presenting more than one Broadway production over the period of a season," depending on the success of the initial program. Michael Ellis, co-producer of the Broadway production with William Hammerstein, said that the theatrical production was possible only because of the 60% backing by the broadcasting company.

He noted that although the theater has only talked about the possible effects such a venture might have on Broadway, now "we will have the chance to find out."

"The Advocate," which stars James Daly, is a drama of an attorney who defends unpopular clients despite threats to his personal and professional life. It is based on the experiences of the defense attorneys in the Sacco and Vanzetti case.

The play is the first by Robert Noah, a creator of TV quiz shows for Goodson-Todman Productions.

with all tape at 6 p.m. July 22, with editing and run throughs up to about 9:05 p.m., 25 minutes before air time.

It is estimated that the network took a \$45,000 gamble, the approximate cost of moving equipment and people to Moscow, for at the time there was no assurance of approval.

Veteran Coverage ■ ABC-TV has covered the meet for the past three years—two years before in Moscow. In the current agreement, the Russians had specified that the coverage be filmed, that shooting not be permitted outside of the stadium and that all equipment and produced be crated and packaged immediately after the meet for shipping back to the United States. The building of a control room also was part of the pact.

ABC-TV had planned its coverage from the first of this year but initial negotiations had not sealed the agreement to the point of visa granting.

Reasons for the Russian attitude that caused the tight schedule are not known through the following may have affected the situation to some degree:

Taping in Moscow is unusual, nuclear test ban talks were in progress, the Chinese Communist delegation was in Moscow, the international film festival was being held and two American circus companies were there.

The sports special was sponsored by Chesebrough-Pond's Inc., through Norman, Craig & Kummel; the Goodyear Tire & Rubber Co., through Young & Rubicam, and Whitehall Laboratories, through Ted Bates & Co. ABC-TV announced on July 25 that "by popular demand" it would telecast highlights of the meet again in prime time to both eastern and central time zones but in an edited, 60-minute version (Friday, Aug. 2, 7:30-8:30 p.m. EDT).

RED TAPE, VIDEO TAPE ABC-TV on a tight schedule in coverage of track meet

The United States-Russian track meet in Moscow on July 20 and 21 may have had speed and excitement but there were no less ingredients in the race with time of ABC-TV crews and producers covering the events.

In an interview with BROADCASTING last week, executive producer Roone Arledge detailed the statistical count-down from the July 17 night flight from New York to Moscow and on up to show time for the 90-minute telecast at 9:30 p.m. on July 23 five nights later.

At the time of the flight at 8:30 p.m., the network production unit had yet to receive formal Russian approval for coverage of the meet. Visas had been obtained (just hours earlier) at 4 p.m. On arrival July 18 at 8 p.m. Moscow time, the producers began a series of meetings with officials for coverage approval and movement from the airport of the some 16,000 pounds of TV tape

equipment the 21-man crew brought with it to record the proceedings at Lenin Stadium.

Tape Is Tape ■ But it was red tape and not only video tape—which the Russians apparently couldn't see as a necessary "substitute" for film cameras—that ate up precious hours up into the late evening hours on July 19. Equipment at last moved to the stadium by about 10 p.m. and a control room built, cables laid and camera positions staked.

Preparations were completed by 10 in the morning on July 20, testing underway by noon, and at 3:45 p.m. the crew was checking its camera shots and taping introductions. At 5 p.m. the track meet was on and the taping started. That day's taping was edited on the morning of July 21 and the first cut enplaned that night for New York. Cameras were then changed to fit coverage requirements on July 21, the second day of the meet. At 2 p.m., new camera positions were completed and cables relaid, taping was performed from 4-8:30 p.m. and editing and custom clearance to 6 a.m. on July 22.

The crew was back in New York

Suggestions sought from scientists

Social scientists throughout the country have been invited to submit proposed research projects to be considered in a government-backed study of the effect of television on children.

The study, sponsored by the Department of Health, Education and Welfare and to be financed by private contributions, has been slow getting off the ground. It was ordered over a year ago as an outgrowth of hearings by the Senate Juvenile Delinquency Subcommittee (BROADCASTING, July 9, 1962).

A Joint Committee for Research on TV and Children was formed to oversee the study and this committee last week sent letters to several thousand social scientists seeking fruitful areas for investigation. Proposals must be submitted in less than 1,500 words to the Joint Committee, Dr. Ralph Garry,

Great Personalities! Great TV!



KAY CALLS 9 a.m. Monday through Friday



CAP'N JIM'S POPEYE CLUB 4:30 p.m. Monday through Friday



LUNCHEON AT THE ONES 1 p.m. Monday through Friday



By WILLIAMS MICKEY MOUSE CLUB 5 p.m. Monday through Friday

The Eyes of Pittsburgh **CHANNEL 11** NB **WIIC**

REPRESENTED NATIONALLY BY BLAIR TV

GREECE

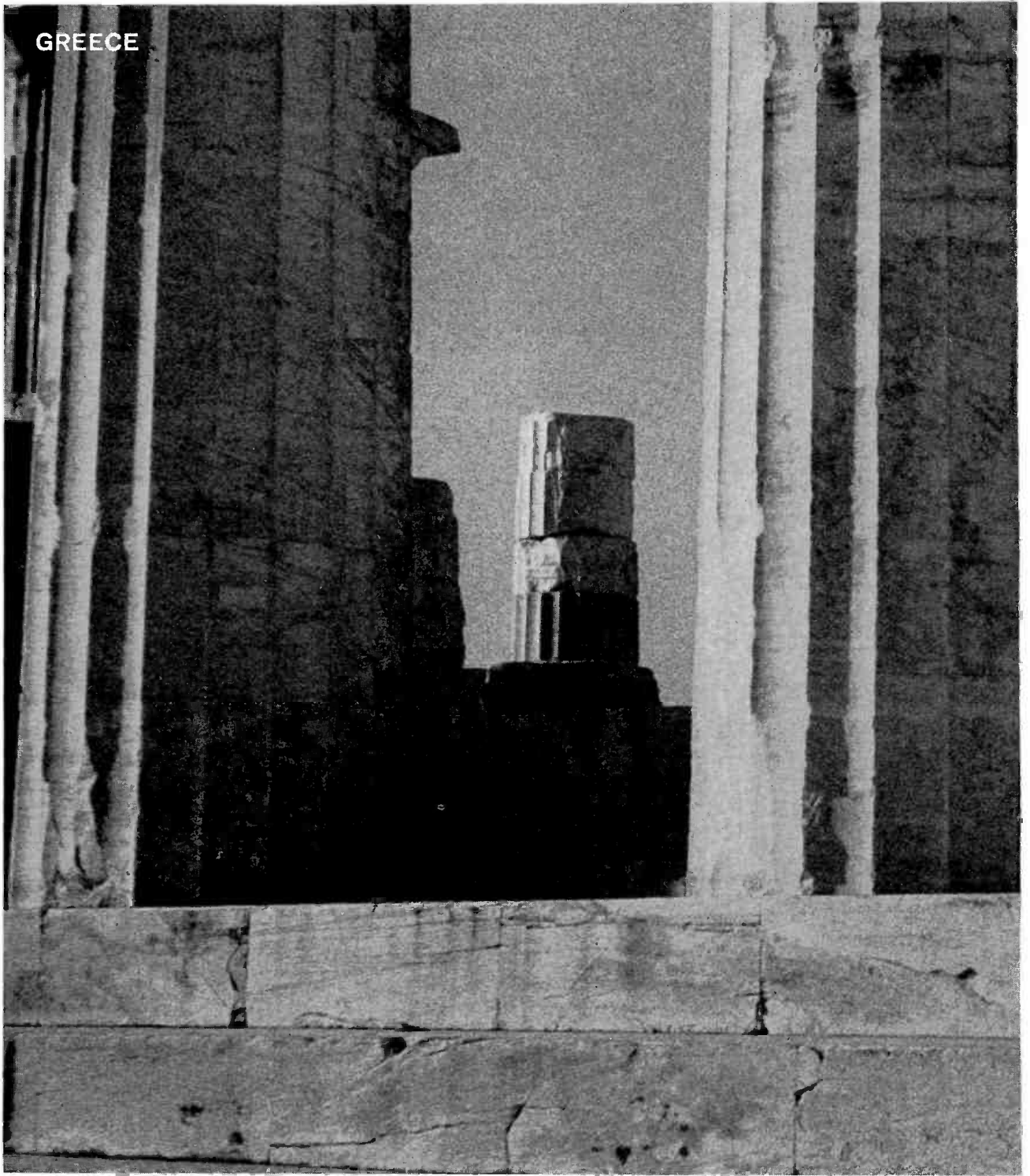

News Columns

But what's so newsy about ancient Greece? What's so pressing about the Battle of Marathon, the trial of Socrates or a performance in the theatre at Epidaurus?

The answer, says NBC News, is "plenty." And who can deny that the past and present are tied together inextricably in the flow of human affairs?

That's why next season's actuality specials on NBC-TV will range all the way from an exploration of Greece's Golden Age to an up-to-the-minute study of American foreign policy.

Whether the datelines read "B.C." or "R.N." (for "right now"), this network's news specials are unique in broadcast journalism.

No better proof of that is needed, really, than the reception accorded the two most talked-about

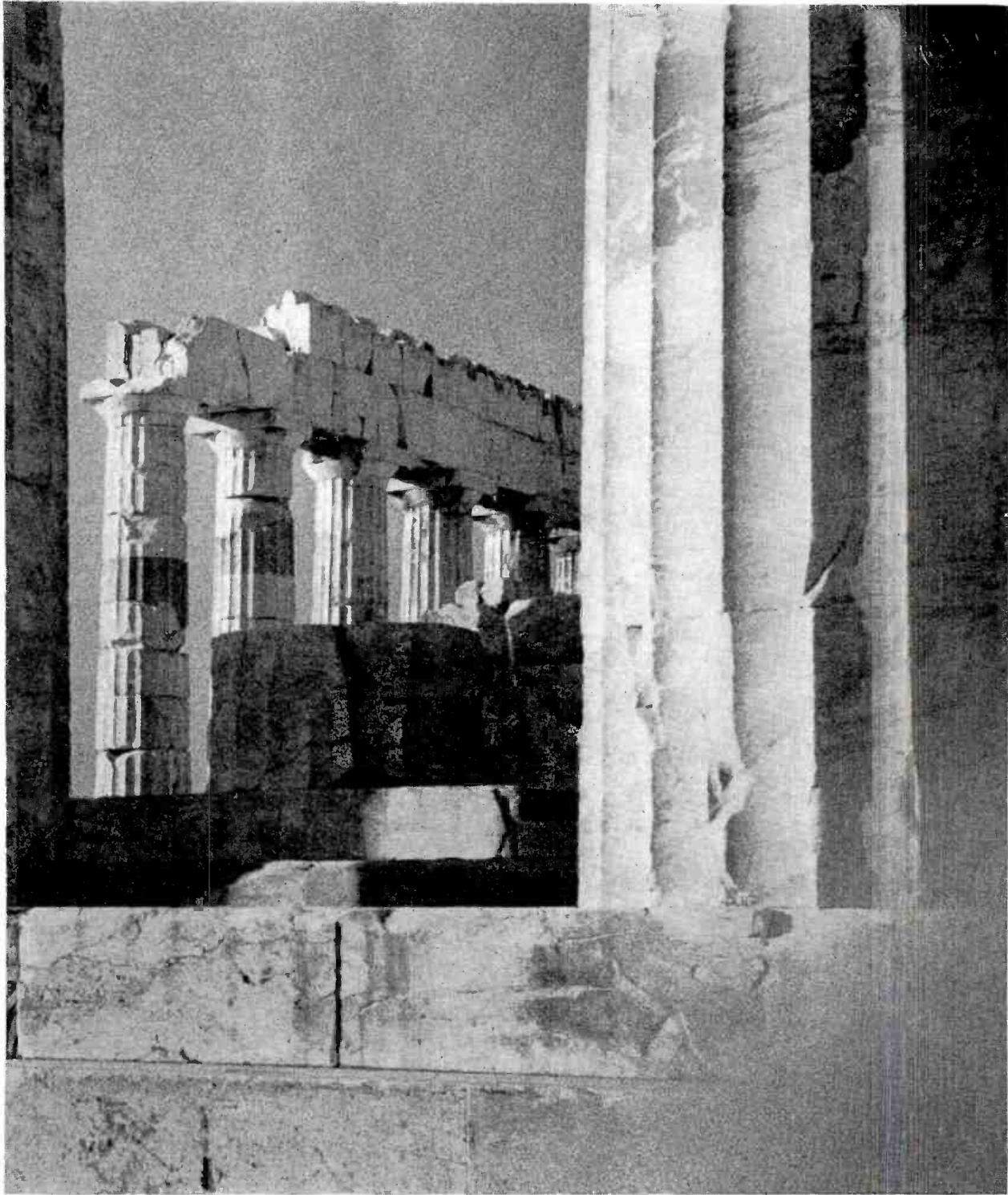

“actualities” of the past two seasons.

Just this Spring, “The Kremlin” explored the last eight centuries of Russian history through an unprecedented look behind the walls of Moscow’s storied citadel. The nation’s critics hailed it as a television masterpiece.

Then, last December, it was a phenomenon of *current* history that held NBC viewers spellbound. “The Tunnel’s” on-the-scene, start-to-finish cov-

erage of an underground escape into West Berlin won a flock of important prizes, among them the Emmy for “Program of the Year.”

Next season’s news specials will be dealing with subjects as varied as race relations, a journey on the Orient Express, and 20th-century warfare. But one aim will be shared by all: making this complex age of ours just a bit easier to understand.



Look to NBC for the best combination of news, information and entertainment.

secretary, 10 Craigie Street, Cambridge 38, Mass., by Sept. 15.

Bernard Russell, special assistant to the secretary of HEW, is chairman of the committee. Other members, all from the industry, include Melvin A. Goldberg, vice president-research director of the National Association of Broadcasters; Julius Barnathan, ABC; Frank Shakespeare, CBS, and Louis Hausman, NBC.

Accompanying last week's invitation for bids were proceedings of a February conference in New York among 25 social scientists. This conference suggested broad areas of research into the question of TV's effect on children.

After definite projects of study are selected by the committee, contracts will be awarded to various institutions in specific areas of research. Mr. Russell predicted that some of these studies will be completed in months while others will take years.

International festival planned by WNDT(TV)

Educational station, WNDT(TV) New York, announced plans last week for an international television festival, to be presented on two or more weekends in October. The station has sent out invitations to 19 countries to participate, and indicated it will wait until response is received before making specific plans for the shows.

Stations in the various countries are being asked to submit from one to three shows produced originally for domestic viewing in the fields of drama, documentary, music, dance or comedy.

Samuel B. Gould, station president

and general manager, said the program will be "one of the most ambitious projects" the station has undertaken.

Countries invited to participate were Australia, Mexico, Japan, Great Britain, Italy, Sweden, Canada, Germany, France, Czechoslovakia, Ireland, Spain, Argentina, Chile, Norway, Venezuela, Brazil, Colombia and Russia.

Sonderling stations to 'sell' democracy

The six Sonderling radio stations will try to "sell" educational material with a year-long campaign of spot announcements aimed at teaching "the full concept of American democracy," it was announced last week.

The series, titled "Declarations for Democracy," was prepared and will be voiced by Professor Robert A. Scalapino, chairman of the political science department of the University of California at Berkeley. Varying from 80 to 95 seconds, the spots are designed "to provide the answer to a question on American democratic principles or rebutt a communist or fascist anti-American thrust."

Twenty-six of the spots have already been prepared and are scheduled for broadcast over the next few weeks. An additional 95 are currently in preparation for the remainder of the year. Egmont Sonderling, president of the Sonderling stations, said he plans to make the scripts and/or tapes available to any other station which would like to present them.

Sonderling stations are WOPA-AM-FM Oak Park, Ill., KDIA Oakland, Calif., WDIA Memphis, and KFOX-AM-FM Long Beach, Calif.

Time-Life and Drew to syndicate TV shows

Ten one-hour films of a dramatic documentary nature, co-produced by Bob Drew Associates and Time-Life Broadcast, are being placed in worldwide syndication by Peter M. Robeck & Co.

Among the films to be offered are "The Chair," the story of the successful legal fight for the commutation of Paul Crump's death sentence; "Football," an examination at two high school coaches and their fiercely competitive teams; "Susan," the story of the life and death of a play featuring Jane Fonda, and "Blackie," a recounting of a veteran airline pilot's last trans-Atlantic flight before retirement. Other films also will deal with people in "times of deep emotional stress."

A Time-Life Broadcast spokesman said the series marks the company's return to the TV film syndication field after an absence of about 10 years. In the network area, co-productions of Time-Life Broadcast and Drew have appeared on ABC-TV's *Close-Up!* series; on CBS-TV sports programs and on NBC-TV's *Today* and *Tonight* ser-

'Crowning Experience' debut

WBAL-TV Baltimore will on Aug. 19 present the world television premiere of *The Crowning Experience* a story of American educator Mary McLeod Bethune who, born of slave parents, eventually became a presidential advisor. A color film production of Moral Re-Armament, the stars include singer Muriel Smith. Joel McCrea introduces the film.

GOVERNMENT

Report details candidates' complaints

SENATE SUBCOMMITTEE BRIEFED ON HOW STATIONS HANDLED THEM

Should a broadcast licensee give free time to a political candidate who complains that the seating plan of a joint TV appearance gave his opponent an advantage?

What should a licensee do for a candidate who complains that newspapers failed to list his name in a time slot for which he has scheduled a paid political broadcast?

How about giving free time to a man who says he deserves it so he can announce his candidacy in the middle of a campaign?

These were some of the problems—all worked out by broadcasters without appeal to the FCC—during 1962 coverage of campaigns for the U. S. Senate. The nature of these complaints and

other details of licensee experience in all 1962 political races are contained in a special report prepared by the FCC for the Senate Watchdog Subcommittee.

The information will become a part of the hearing record of a completed Senate Communications Subcommittee hearing on bills to suspend equal time provisions in various races next year. It was requested during the hearing by Senator Ralph Yarborough (D-Tex.), watchdog chairman (BROADCASTING, July 1).

The Senate communications unit has ended its hearing and has the bills under advisement. The new FCC report, a supplement to an earlier document which provided statistical data on the 1962 political broadcasting experi-

ence of 5,300 licensees (BROADCASTING, June 10), will be considered when the senators sit down to hammer out a bill. Proposals under consideration include one to repeal Section 315 entirely, another which would suspend the equal time section for presidential, gubernatorial and congressional races next year, and a third version limiting suspension to 1964's presidential and vice presidential races. The House already has passed a bill like the latter (BROADCASTING, June 24).

The Human Side ■ The FCC's supplemental report goes behind the myriad of figures it offered the Congress in June and breaks down some of the statistics with the names of candidates and stations—all information culled

GROUP W MEANS NEW SOURCES OF PROGRAMMING

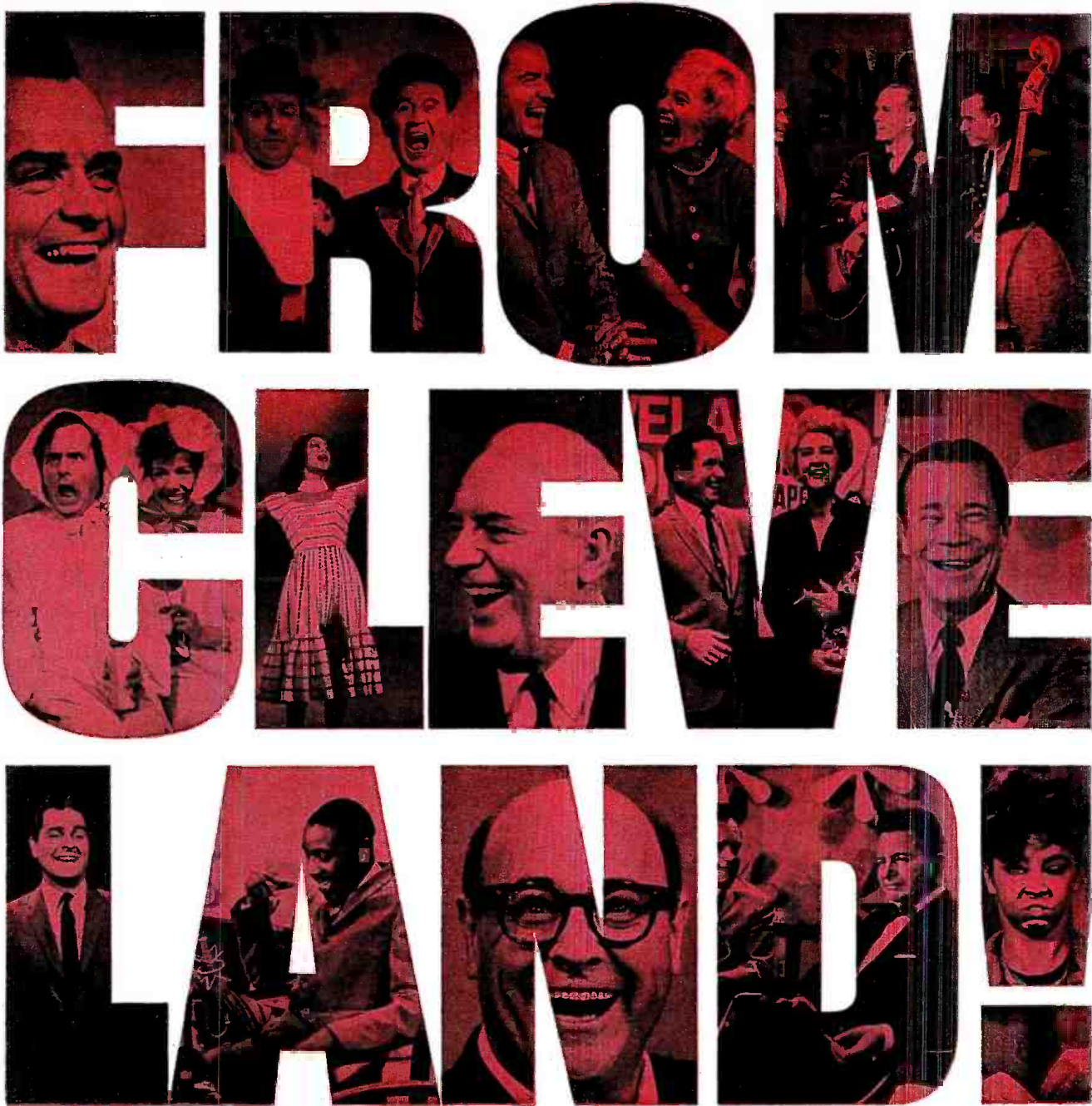

THE MIKE DOUGLAS SHOW

Local show goes Group. "The Mike Douglas Show" is a product of a Group W—Westinghouse Broadcasting Company—station. KYW-TV Cleveland. It is scheduled to be seen on all five Group W television stations.

A big success in Cleveland, "The Mike Douglas Show" brings a fresh personality into the medium; and daily hour-and-a-half programs of variety, laughter, and big name guests. It will be a source of pleasure to audiences in Boston, Baltimore, Pittsburgh,

and San Francisco, as well as its own hometown. It is even being made available to other stations outside of Group W throughout the country.

The Group, unlike the network or the individual station, has *both* local flexibility and creative and financial resources. "The Mike Douglas Show" is a case in point. It demonstrates the ability of a single station to contribute to the vitality of Group. It also demonstrates the ability of

Group W to use these resources and this flexibility to provide new and interesting sources of programming for the industry.



- BOSTON WBZ - WBZ-TV
- NEW YORK WINS
- BALTIMORE WJZ-TV
- PITTSBURGH KDKA - KOKA-TV
- CLEVELAND KYW - KYW-TV
- FORT WAYNE WOWO
- CHICAGO WINO
- SAN FRANCISCO KPIX

WESTINGHOUSE BROADCASTING COMPANY

A contender's opinions on Section 315

New York Governor Nelson A. Rockefeller, considered a contender for the Republican presidential nomination in 1964, favors suspension of Section 315 for next year's presidential race, but does not favor moving the suspension down to the



Governor Rockefeller

governor level.

The Governor's opinion is contained in a letter written last week to the Senate Commerce Committee, which is considering legislation to suspend Section 315 in various races (see page 60).

Governor Rockefeller said broadcasting has provided a great service "in making substantial amount of prime time available free of charge to candidates for public office." Noting his "very deep respect for the rights of minority groups to be heard on public issues," the governor said, "I believe Congress should move with caution in considering any legislation which would modify or abridge this right."

The committee heard from two other governors last week. Both supported S 252, a bill to include gubernatorial races in a 1964 suspension of Section 315. The governors: Endicott Peabody (D) of Massachusetts and Carl Sanders (D) of Georgia.

Earlier 32 governors had told the committee that they supported the bill (CLOSED CIRCUIT, July 29).

from the questionnaires.

The following is a sampling of the new report:

The FCC found that while 1,200 licensees gave sustaining time to political discussion last year, the amounts varied widely. Some stations gave as little as 30 minutes, but at the other extreme were these:

- In TV, four stations gave between 10 and 15 hours: KNBC and KNXT, both Los Angeles; WCBS-TV New York and WKOW Madison, Wis. WNBC-TV New York gave between 15 and 19 hours. Three stations — all Hawaiian — gave more than 20 hours each: KHJK Hilo and KHVH-TV Honolulu (both licensed to Kaiser Industries Corp.) and KMVI-TV Wailuku (Maui Publishing Co. Ltd.).

- In AM, 16 stations gave between 10 and 15 hours; nine gave from 15-20 hours and eight provided over 20.

Senator Yarborough was equally interested in stations which chose not to broadcast political programming. Of 10 initially reported to have told the FCC they had no political activity on their air (other than news), four were found to be noncommercial, one engaged in a pay-TV experiment and one was not on the air during the campaign. But four commercial TV's were rated as non-active: WATR-TV Waterbury, Conn.; WLOX-TV Biloxi, Miss.; WISE-TV Asheville, N. C.; and KCBY-TV Coos Bay, Ore.

It was noted that political activity

varies from state to state from year to year, but all states had congressional races in 1962.

Of 100 AM's reporting no activity, two-thirds are located in four southern states: Virginia (27), Mississippi (25), Louisiana and North Carolina (11 each). (In sections of some southern states, political activity is negligible due to a one-party system.)

Among independent FM's (those not connected with AM's) 89 reported no political activity. Nineteen are located in California; eight are in Illinois; seven in Ohio and six in Texas.

Where the supplemental report humanizes the political information is in the answers to a question about complaints stations received which were not referred to the FCC. For the report's purposes answers were confined to senatorial races.

The report shows that 16 TV stations and 24 AM's had complaints of this nature.

The Fulbright Complaints — Many of these complaints were traced to the senatorial campaign in Arkansas where Senator J. W. Fulbright (D-Ark.) faced Dr. Kenneth Jones, a Republican. James H. Pilkington, the senator's campaign manager, wired 17 AM's in Arkansas on the weekend of Nov. 3-4 that portions of spots for Dr. Jones contained statements which were "libelous, slanderous and defamatory of Senator Fulbright." The stations were

warned to consult their attorneys before continuing with the spot schedule.

Seven stations either dropped the spots or asked the GOP for new copy. One of these said it was concerned that its location in the senator's home town might have an effect on a local jury if the complaint went to court.

Six stations continued to run the spots. Two read the complaint on the air and two told Mr. Pilkington they didn't have the GOP schedule.

Elsewhere, KMED-AM-TV Medford, Ore., received a complaint from a candidate who said the station's regional representative opposed him. The station told the FCC it resolved the problem on its own.

KGW-TV Portland, Ore., heard from one of six candidates for the Republican senatorial nomination who had appeared in a joint telecast. He deserved free time, he said, because an opponent had an advantageous seating position. The station decided it had been fair and turned the man down.

WTVT(TV) Tampa-St. Petersburg, Fla., reported that a Republican candidate complained to the station that two of four newspaper listings for his paid 15-minute political appearance failed to use his name. The station said it had no control over such listings.

KKTV(TV) Colorado Springs, Colo., said it had a request for free time in the middle of the campaign from a man who wanted to announce his candidacy. The station refused him and explained that he was not a legally qualified candidate. There was no further complaint.

KOA-TV Denver offered free time to a minority candidate who had refused to participate in a joint appearance because one of the candidates scheduled was a Socialist.

WTVH(TV) Peoria, Ill., said it had complaints from two Democratic officials when it tagged a spot for the Republican candidate as paid for by the "General Democratic Party of Illinois." WTVH stopped the spot.

Socialists who requested free time from WABC-TV New York were granted the exposure after Senator Jacob K. Javits (R-N. Y.) appeared on *All America Wants to Know*.

When Chicago's Mayor Richard J. Daley complained about the substance of a WIND Chicago newscast, the station aired his statement.

The FCC last week...

- Gave Herbert M. Hoppe 30 days to explain why he shouldn't be fined \$100 for buying the construction permit of WVAL Sauk Rapids, Minn., without commission permission. Mr. Hoppe bought out his partner in the venture, Carl A. Nierengarten. The FCC's action also retroactively granted Mr.

ADDRESSES		ADDRESSES	
Aluminum Co. of America	ED4-7751	IBM	FR5-1491
Amson Oil	537-6171	Int. Harvester	ED4-2851
Armco Steel	366-5726	International Paper	ED2-6068
Armour	ED4-4223	Kodak Records	377-4585
Exhibition Steel	ED4-5334	Monsanto Chemical	ED3-2101
Borden	FR7-6175	National Bony Products	377-3421
Chrysler	376-3476	Phillips Petroleum	EX9-4347
Citibank	375-3447	Proctor & Knebel	352-6173
Continental Can	FR6-7449	RCA	393-3996
Douglas Aircraft	FR6-8471	Republic Steel	FR6-6534
Du Pont	375-5361	Shell Oil	377-9701
Eastman	EX9-7691	Sperry Mobil	ED3-7191
Ford	EX9-1511	Smelter Oil	EX9-3381
General Dynamics	TR3-5521	Stamperland Oil	376-2911
General Electric	375-5571	Swift	398-2171
General Foods	375-2511	Union Carbide	FR5-3383
General Motors	ED3-8415	U.S. Rubber	375-3731
Goodyear	ED3-1161	Western Electric	ED4-0881
Guaf Oil	376-9831	Westinghouse	FR7-3471
Humble Oil & Refining Co.	TR3-2211		

The company she keeps

Forty of the fifty largest U.S. corporations have a Charlotte address.

Not because of her beauty. But because Charlotte is one of the largest commercial and distribution centers in the Southeast.

Charlotte ranks 5th in the wholesale distribution of chemicals... 8th in per family retail sales.

There are more people within a 75-mile radius of Charlotte than in a corresponding radius around Atlanta, Indianapolis, Kansas City or Minneapolis.

The largest businesses in America are in Charlotte to reach these people.

You can reach them through WBT Radio Charlotte.

For over 40 years, WBT has had the largest adult audience for the 37-county basic area; the audience that receives and spends most of the Charlotte area's \$2,612,784,000 worth of spending money.

Join the company that Charlotte keeps—through WBT, the station of responsible programming, outstanding service, finer entertainment.

WBT RADIO CHARLOTTE · Jefferson Standard Broadcasting Company

Represented nationally by John Blair & Company.

Senator Keating calls Pacifica inquiry 'useful'

A member of the Senate Internal Security Subcommittee said last week that its closed-door hearing on possible Communist infiltration of the Pacifica Foundation, licensee of three non-commercial FM stations, brought out useful information.

Senator Kenneth B. Keating (R-N. Y.) said it is not the subcommittee's function "to judge or to condemn any individual, but it is useful that certain facts were brought to light so that the directors of the Pacifica Foundation and the public can approach the problem fully informed."

Late last month the subcommittee made public testimony obtained during its secret January hearing on the foundation's stations (BROADCASTING, July 29). No subcommittee member other than Senator Keating has commented publicly on the hearing, and no report or findings accompanied publication of the transcript. But

the pattern of questioning, the responses of some witnesses and annotation of names mentioned in the hearing transcript showed that some had been members of the Communist party. Other persons not called but formerly associated with Pacifica were linked to the party by the subcommittee.

Trevor K. Thomas, Pacifica acting president and one of seven witnesses called before the subcommittee, said when the hearing transcript was released that foundation stations would not change their policies. Pacifica, whose FM stations are all listener-supported, is licensee of KPFA Berkeley and KPFA Los Angeles, both California, and WBAI New York.

Although renewal of Pacifica's licenses was still being held up by the FCC last week, it was learned that the agency has had the subcommittee transcript since January, although

it was not made public until last month.

The subcommittee expressed concern to several witnesses at Pacifica's failure for some time to identify the political backgrounds of some persons who appeared as commentators on its stations. The stations now identify all commentators, who include persons reflecting political viewpoints from Communist to ultraright, a Pacifica spokesman said.

Senator Keating commented last week that while communications media have a right to present "a broad spectrum of opinion," they have a duty "to differentiate between factual reporting and editorial comment. Similarly, radio stations [purporting] to present an unbiased view of current events should, in fairness to the listening public, identify any persons on their policy-making staff who might have an interest in slanting the news."

Hoppe's covering application for the assignment, dismissed as moot his request for more time to build the station, denied opposing petitions filed by WJON St. Cloud, Minn., and authorized WVAL to begin with program tests.

- Reserved channel 33 in Hazard, Ky., for educational use and deleted non-commercial channel 19. The Kentucky Authority for Educational Television asked for the switch because of interference from WLEX-TV (ch. 18) Lexington. The authority had also asked the addition of channel 19 to channel 78 in Ashland, but the commission decided to consider the request separately, inviting comments on the substitution of channel 19 for channel 78, although it noted that "there is nothing to prevent" comments from recommending the assignment of both channels to Ashland. Because of possible interference, Canadian authorities also will have to pass on the channel 19 proposal.

- Announced the adoption of an expanded table of television assignments in Puerto Rico and the Virgin Islands (see page 95). The commission said the additional channels will further the development of UHF in the islands.

- Modified its newly adopted FM table of assignments (BROADCASTING, July 29) by making a number of channel changes in Michigan and Indiana (see page 95).

- Denied petitions by Zenith Radio Corp. and Warick Manufacturing Corp. requesting that the commission reconsider its new rule to allow UHF stations to operate with an aural power as low as one-tenth of their visual power (BROADCASTING, April 1).

FCC orders hearing for KGLC sale

The FCC's concern over the common ownership of broadcasting stations and newspapers in the same community has been growing. It resulted last week in an order for a hearing on an application to sell the only radio station in Miami, Okla., to the city's only newspaper.

Miami Broadcasting Co., licensee of KGLC Miami, has applied to sell the station to Miami Newspapers Inc., publishers of the *Miami News Record*. The commission said it wants to determine if the sale would result in a concentration of media control.

Commission officials cannot recall another transfer case in which the agency ordered a hearing on this issue alone.

The commission's concern with concentration of media ownership has intensified as a result of the House Antitrust Subcommittee hearings on the subject last winter.

In ordering the hearing, the commission also had in mind a recent U. S. Supreme Court decision holding that the FCC should consider the possible antitrust aspects involved in the proposed sale of the only broadcast facility in an area to the publisher of the only newspaper.

The commission's interest in common ownership, particularly as it concerns the practice of combination advertising rates, has resulted in letters of inquiry being sent to renewal applicants with newspaper connections

(BROADCASTING, June 17). The letters are an aftermath of the House Antitrust Subcommittee hearing on the concentration of ownership of news media.

The commission has no definitive standards by which it would judge cases of combination rate practices, should the letters of inquiry turn up an instance, according to an agency staff member.

A number of businessmen of Miami have opposed approval of the KGLC sale on grounds that Miami Newspapers would create a monopoly detrimental to their businesses. C. C. Woodson, publisher of the *News Record*, allegedly proposed an immediate 50% increase in KGLC's advertising rates as soon as the sale had been arranged (BROADCASTING, March 11).

The commission dismissed requests for denial of the sale, but said that it would welcome "competent testimony" at the hearing.

Commerce Committee costs

Figures released by the clerk of the House of Representatives show that the Commerce Committee, which originates most of the legislation affecting broadcasting, had spent \$86,379.95 by June 30 of \$245,950 appropriated for 1963. This figure reflects only costs for "temporary" help, however, and does not include \$89,569.66 spent on salaries for 14 "statutory employees" during the same period. Statutory employees are committee personnel who are considered to be permanent, although some employees listed as temporary have been with the subcommittee for several years.



Courtesy of The Detroit Institute of Arts

**"PORTRAIT
OF A MAN"**

by Diego Velasquez is a famous character study of a Spanish nobleman in the court of Philip IV. Notable features are its fluid technique and soft pictorial style.

in a class by itself

Masterpiece — *exceptional skill, far-reaching values.* This is the quality of WWJ radio-television service—in entertainment, news, sports, information, and public affairs programming. The results are impressive—in audience loyalty and community stature, and in sales impact for the advertiser on WWJ Radio and Television.

WWJ and WWJ-TV
THE NEWS STATIONS

Owned and Operated by The Detroit News • Affiliated with NBC • National Representatives: Peters, Griffin, Woodward, Inc.

Loevinger cites 'murky' FCC language

GIVES COLLEAGUES LESSON ON 'CONTROLLING PRECEDENT'

FCC Commissioner Lee Loevinger, who joined the commission June 11, may be its newest member, but with his background as a University of Minnesota Law School professor, associate justice of the Minnesota Supreme Court, and Justice Department antitrust chief, he hasn't hesitated to express his views to his colleagues.

Last week, for instance, he issued a concurring statement in an AM case which was, in effect, a brief lecture on the finer points of the principle of stare decisis, or controlling precedent, addressed to fellow Commissioner Kenneth A. Cox. It also commented, unfavorably, on the "murky" language of FCC opinions.

The case involved the request of KGMO Cape Girardeau, Mo., that the commission set aside its grant of a construction permit to the Missouri-Illinois Broadcasting Co., permittee of KZIM Cape Girardeau, and hold a hearing. KGMO alleged that it would suffer economic hardship as a result of the additional competition and would, therefore, have to discontinue some of its public service programming.

Petition Rejected ■ The commission rejected the petition. It said the arguments advanced were too generalized to support the conclusion that an additional AM station (the market now has two) would result in economic injury to KGMO to the extent of affecting the service it rendered the public. The commission said the station should have presented more specific facts, rather than conclusions.

This has become firm commission policy. The agency took this position two weeks ago in denying a request for a hearing on an economic injury issue involving an AM grant in Greensburg, Ind. (BROADCASTING, July 29). It used the same argument last week in denying petitions of KIVA(TV) Yuma, Ariz., that the commission reconsider its CP grants to KXO-TV Inc. and Tele-Broadcasters of California Inc., for TV stations in El Centro, Calif.

FCC Chairman E. William Henry joined Commissioner Cox in dissenting to the KGMO case. But the chairman said only that he would have given KGMO an opportunity to make a more specific argument before deciding on its request for a hearing.

Commissioner Cox said the station should have been allowed to make its argument in a hearing. He said that the commission, in six recent cases, had granted hearings on the issue of economic injury. And in none of these cases, he added, were the arguments requesting hearings any more specific

than those advanced by KGMO.

Loevinger Disagrees ■ In his statement, however, Commissioner Loevinger asserted that Commissioner Cox "misconceives both the principle of controlling precedent, or stare decisis, and the significance of the specific decision involved here."

Sprinkling legal citations through his statement like confetti before the wind, Commissioner Loevinger said the principle of controlling precedent cannot be applied unless there is a legally unifying principle tying two sets of factual situations together.

"Factual situations cannot be . . . mechanically compared without an intervening abstraction of . . . principles, and so cases cannot be controlled . . . by simple analogy. . ."

And none of the decisions cited by Commissioner Cox, he said, provides this "intervening abstraction." In each of the opinions relied on by Commissioner Cox, Commissioner Loevinger said, there is only "a recital of the facts pleaded by the objecting competitor which led the commission to order a hearing."

'Murky' Style ■ "Each of these opinions," Commissioner Loevinger added, "is written in the murky institutional style of the typical commission opinion which tends to blur the issue and mute any statement of controlling principles."

The most that can be said for the six cases, Commissioner Loevinger said, is that the facts involved in them are sufficient to raise the economic injury issue "in the circumstantial setting of each case."

"It is intimated [in the Cox dissent] that considerations or attitudes lurking behind the opinions of the commission in the prior case would, if carried forward to the instant case, compel a different result," Commissioner Loevinger said. But, he added, "this is not a legitimate argument."

Is there any general rule to be gleaned from the commission decision in the Cape Girardeau case? Commissioner Loevinger believes there is: "An objecting competitor seeking to prevent a new grant to an applicant and to raise the [economic injury] issue . . . must assert facts, as distinguished from conclusions, that are sufficient on their face to support the heavy burden of proof that rests upon any proponent of such an issue."

The commissioner's interest in stare decisis isn't a new one. Among the citations contained in his statement is "Loevinger, *An Introduction to Legal Logic* . . . (1952).

Magnuson due at desk

Senator Warren G. Magnuson (D-Wash.), chairman of the Senate Commerce Committee, was released from a Seattle Hospital Monday (July 29) and was expected to return to work in Washington, D. C., this week. Senator Magnuson suffered a recurrence of malaria late last month while visiting his home state.

Senator John O. Pastore (D-R. I.), acting chairman in Senator Magnuson's absence and regularly chairman of the communications subcommittee, was designated last week as one of six senators who were to fly to Moscow for the signing of a nuclear test ban treaty. Senator Pastore is also chairman of the Joint Committee on Atomic Energy.

Moss plans hearing on military news

A House subcommittee which has waged many of the Congress's own freedom of information battles during the past eight years is preparing to conduct a hearing on a problem affecting broadcast and print newsmen.

The problem: what authority do the military services have to obstruct news coverage of military accidents which happen in civilian areas?

Representative John E. Moss (D-Calif.), chairman of the House Foreign Operations and Government Information Subcommittee, says the Pentagon has failed to provide satisfactory answers to questions he has asked in correspondence with the Department of Defense and the Air Force (CLOSED CIRCUIT, April 15 and BROADCASTING, May 13, et seq.). Now, he says, he is going to conduct a hearing. No date has been set.

New operator rule held up for 60 days

The FCC last week postponed for 60 days the Aug. 19 effective date of the rule adopted July 10 which will permit certain AM and FM stations to employ first-class radiotelephone operators on a part-time contract basis.

The stay will allow the commission time, after its August recess, to make a decision on a petition for reconsideration of the rule filed by the National Association of Broadcast Employees and Technicians, AFL-CIO (BROADCASTING, July 29). The union said use of part-time engineers would result in poorer technical service.



Check here for happy results

Your listening audience is the most valuable asset you have. Keeping them happy and loyal is a combination of many things, not the least of which is the equipment you have in your station. Happy listeners mean happy advertisers. □ With Collins equipment, you broadcast the cleanest sig-

nal on the air. We've added two new pieces of equipment to our line... the 900C-1 FM Stereo Modulation Monitor and the 26U-2 Stereo Limiting Amplifier. □ When quality sound is what you're after, go Collins. Let us tell you what Collins transmitters, stereo generators, broadband exciters, the

new monitor and limiter can do for your station. Call or write today.

COLLINS RADIO COMPANY
 Cedar Rapids • Dallas • Los Angeles
 • New York • International, Dallas



'All' becomes 'other' in modified statement

FCC 'MINOR' CHANGE IS MAJOR ONE IN NAB'S EYES

The FCC doesn't expect broadcasters who air programs on controversial issues to offer opportunities for reply to "all" groups in their community.

The commission sought to make this clear last week in modifying the language of its statement reminding broadcasters they must observe the fairness doctrine when presenting controversial programs (BROADCASTING, July 29).

Commission officials describe the changes as "minor editorial corrections" that should have been made before the document was released. But representatives of the National Association of Broadcasters consider them important.

The changes meet some of the specific objections that were raised by NAB President LeRoy Collins in a letter to the commission last week protesting the statement.

The document originally said a licensee presenting programs on controversial issues of public importance, such as segregation, "must offer spokesmen for all responsible groups within the community similar opportunities for the expression of the viewpoints of their respective groups."

The modified passage says that the opportunities must be given to spokesmen for "other" (instead of "all") groups and that the viewpoints to be

expressed are those that are "contrasting."

NAB staff members were informed the changes were being made when they went to the commission offices Thursday (Aug. 1) to deliver Governor Collins's letter.

Douglas Anello, NAB general counsel, called on FCC Chairman E. William Henry; Vincent Wasilewski, NAB executive vice president, visited Commissioner Robert E. Lee and Paul Comstock, NAB vice president for governmental affairs, talked with Commissioners Kenneth A. Cox and Lee Loevinger.

The NAB officials said later they were told the changes were intended to make clear that the commission has not changed its previous policy in the application of the fairness doctrine.

In his letter, Governor Collins expressed particular concern about the passage which had already been changed. He said it didn't conform with the association's understanding of commission policy.

"Taken literally," he said, "the statement would seem to require that the licensee must present the viewpoint of every responsible group which may wish to be heard—even where the various groups may hold substantially the same viewpoint."

Governor Collins also said the com-

mission "should not attempt to define in detail, by rule or otherwise, the licensees' responsibilities under the fairness doctrine." He said the doctrine is a standard which is dependent on the individual broadcaster's judgment.

As a result, he said, a rule of fairness that would cover the "myriad of circumstances that can and do arise" cannot be prescribed in advance. He said this concept is embodied in the commission's 1949 order authorizing editorializing by broadcasters.

Pulse asks dismissal of WAME's suit

WAME Miami, which is suing separately two major broadcast research companies on complaints that they have misrepresented ratings reports, may learn today (Monday) how it is faring in court.

Dade County Circuit Court Judge George E. Schultz said Thursday (Aug. 1) that he would take under advisement until today The Pulse Inc.'s motion to dismiss. WAME is asking \$250,000 from Pulse (BROADCASTING, May 6, et seq.).

The research company argued last week that the state court has no jurisdiction in the case because Pulse has never done a survey in Florida and doesn't do business there. WAME, which claims that's the problem—that Pulse failed to perform surveys for which it has charged, asked if Pulse would stipulate that the surveys were not performed if WAME stipulated the court had no jurisdiction. Pulse then explained that surveys were performed all right, but by individuals who contracted with Pulse.

A Florida woman who testified she contracted with Pulse said under WAME questioning that the surveys were performed according to Pulse methods and controls. WAME's other suit, which asks \$250,000 from the A. C. Nielsen Co., resumes in the U. S. District Court in Miami today. The complaint was dismissed on a Nielsen motion, but the station was allowed to amend its complaint, which it will file today.

VOA increases weekly schedule by 7 hours

The Voice of America, radio arm of the U. S. Information Agency, has added seven hours to its weekly schedule of broadcasts, the USIA announced yesterday (Aug. 4).

By doubling its daily one-hour regional English-language program service to Africa, VOA has boosted its total weekly air time to 796 hours and 15 minutes in 36 languages, USIA said.

FTC rerun on purity in TV demonstrations

"Spurious or fake" television commercials were used by Libby-Owens-Ford Glass Co. and General Motors Co. in a 1957-58 safety plate glass campaign, the Federal Trade Commission ruled last week. In a decision written by Commissioner Everette MacIntyre, the FTC said that, contrary to representations made in the TV commercials:

- The safety plate glass used in the side windows of GM cars was of lower grade and quality than that used in the windshields of GM cars.

- The automobile safety sheet glass used in the side windows of non-GM cars was not of the same grade and quality as the sheet glass used in home windows.

- The TV films were not accurate demonstrations of the perceptible disparity between the optical distortion of automobile safety plate glass and safety sheet glass under ordinary conditions of use.

In denying a GM plea that the

safety campaign was primarily LOF's, the FTC held that both companies were guilty of the misrepresentations. LOF aired 22 TV commercials, using only GM cars, during 1957 college football telecasts; GM used one safety glass commercial twice during the same period.

In its opinion, the trade commission cited its famous "sandpaper" decision against Colgate-Palmolive Co.'s Rapid Shave cream and said the same principles apply (BROADCASTING, March 11).

The primary issue in the LOF-GM case, as in the earlier Colgate decision, the FTC said, "concerns the use of demonstrations on television which are fake or at least partly rigged performances but which give to the viewer the impression that an actual experiment or an actual demonstration is taking place."

Libby-Owens-Ford and General Motors have 20 days to file objections to the FTC decision.



YOU MAY NEVER DEAL 13 OF A SUIT* —

BUT... WKZO Radio Takes Every Trick in Kalamazoo and Greater Western Michigan!

6-COUNTY PULSE REPORT			
KALAMAZOO RETAIL TRADING AREA—SEPTEMBER, 1962			
SHARE OF AUDIENCE—MONDAY-FRIDAY			
	WKZO	Station "B"	Station "C"
6 A.M. - 12 NOON	30	19	5
12 NOON - 6 P.M.	27	18	6
6 P.M. - MIDNIGHT	40	17	X

All honors in Greater Western Michigan: NCS '61 tallies WKZO Radio's circulation with trumping every radio rival in the *area*—with 40.4% more than all other *Kalamazoo* stations combined!

Almost a perfect hand: The 6-county Pulse of Sept. '62 shows WKZO Radio outscoring all others in 358 of 360 quarter-hours surveyed, and grand-slammng *all* hours surveyed both in total listening and adult listening.

Not penny-a-point stuff, either: Sales Management has predicted that Kalamazoo alone will outgrow all other U.S. cities in personal income and retail sales between 1960 and 1965.

*The odds against it are 158,753,389,900 to 1.

Talk contract soon with your Avery-Knodel man!



The Felzer Stations

RADIO

WKZO KALAMAZOO-BATTLE CREEK
 WJEF GRAND RAPIDS
 WJEF-FM GRAND RAPIDS-KALAMAZOO
 WWTV-FM CADILLAC

TELEVISION

WKZO-TV GRAND RAPIDS-KALAMAZOO
 WWTV/ CADILLAC-TRAVERSE CITY
 /WWUP-TV SAULT STE. MARIE
 KOLN-TV/ LINCOLN, NEBRASKA
 /KGIN-TV GRAND ISLAND, NEB.

WKZO

CBS RADIO FOR KALAMAZOO
 AND GREATER WESTERN MICHIGAN

Avery-Knodel, Inc., Exclusive National Representatives

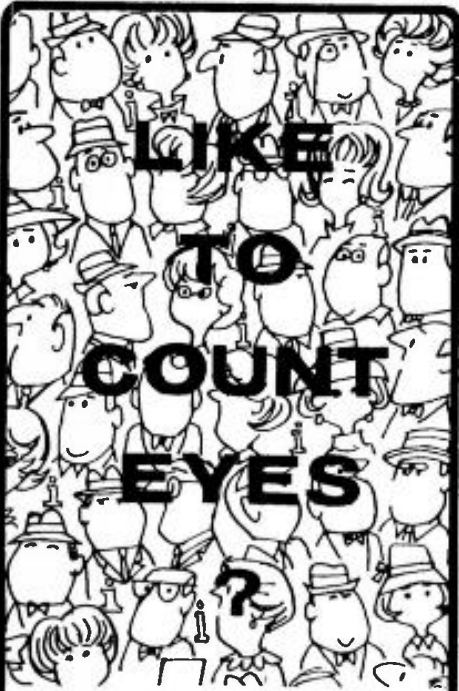

Tell us the number of eyes shown here . . .and you'll get a real eye opener!

GIVE THESE CLUES AN EYE!

These eyes and 1,859,814 more equal the number of orbs looking toward New Bern. For these pupils have learned their lesson well! They know that the New Bern, Greenville and Washington community will on September 1 boast Eastern North Carolina's only full time primary ABC-TV outlet!

GET RICH! Set your sights on this triple rich market . . . and get results that will really dazzle your advertisers!

GET RICH CONTEST! 5003 PRIZES!

- First Prize:** A Case of Imported Martini Olives Stuffed with Cocktail Almonds.
- Second Prize:** A Case of Deluxe Martini Olives Stuffed with Cocktail Onions.
- Third Prize:** A Case of Compact Martini Olives Plain.

To the first 5,000 Runners-up—A case of genuine North Carolina wood toothpicks for use with all three classes of olives.

In case of draw—duplicate olives will be awarded. Winners may substitute lemon peels or onions (unstuffed). Send your Count-The-Eyes-and-Get-Rich Entry now to:

GET RICH CONTEST

Broadcasting Magazine
1735 DeSales Street, N.W., Washington, D.C.

CHANNEL 12



Greenville—NEW BERN—Washington

LET COX VOTE, SAYS DROP-IN FACTION

ABC leads attack on plea for commissioner's abstention

Critics of the FCC decision in the drop-in case last week opposed the proposal that Commissioner Kenneth A. Cox refrain from further participation in that controversial proceeding.

The proposal was made three weeks ago by the Association of Maximum Service Telecasters—which supports the commission's position—on the ground that Commissioner Cox had been connected with the case before his appointment to the commission when he was chief of the agency's Broadcast Bureau (BROADCASTING, July 22).

Commissioner Cox, who was in the minority in the 4-3 decision which rejected the seven short-spaced VHF drop-ins, has become something of a champion to advocates of the drop-ins since filing his dissent last month (BROADCASTING, July 8).

Chief among the 10 petitioners opposing the AMST motion was ABC, which told the commission the proposal "is an afterthought and an ill-conceived attempt to control the result in these proceedings by foreclosing the vote of a commissioner with whose views" the association disagrees.

ABC has long urged approval of the drop-ins, arguing that it needs additional VHF outlets to become fully competitive with NBC and CBS. The others opposing the AMST motion are prospective applicants for the drop-ins.

With the departure of former Chairman Newton N. Minow, who voted with the majority to deny the drop-ins, the commission is now divided 3-3 on the issue. Commissioner Lee Loevinger, who succeeded Mr. Minow, represents the vote that could reverse the decision. His position, however, would be academic if Commissioner Cox withdrew from participation.

Oral Argument Set ■ The FCC, meanwhile, formally announced it will hold oral argument on its order denying the drop-ins for Johnstown, Pa.; Baton Rouge, La.; Dayton, Ohio; Jacksonville, Fla.; Birmingham, Ala.; Knoxville, Tenn., and Charlotte, N. C. (CLOSED CIRCUIT, July 29). However, it moved the date back from Sept. 19 to Oct. 4 because the former falls on the Jewish holiday of Rosh ha-Shanah.

The commission also announced that it had reversed itself on the eighth case in the proceeding—that involving the move-in of koco-TV (ch. 5) Enid, Okla., to Oklahoma City. The commission said it would permit the move-in at short-spacing rather than at standard mileage separation as originally required (CLOSED CIRCUIT, July 29).

The principal reason given by the

commission was that it had concluded that, the station at standard spacing, could not find a transmitter site that would meet Federal Aviation Agency requirements.

Commissioner Cox was absent during the vote on the oral argument matter and was listed as not participating in the Enid case. Commissioner Robert E. Lee dissented to the latter decision.

Commissioner Lee Loevinger issued a concurring statement in the Enid case in which he said he didn't believe AMST—which opposed the short-spacing proposal—had any standing and, therefore, any right to file an "opposition." He emphasized, however, that the Enid case represented "an entirely different issue" from that involved in the drop-ins.

AMST based its motion that Commissioner Cox refrain from participation in the drop-in matter on the contention that the case is essentially adjudicatory, regardless of the rulemaking "label" attached to it. In adjudicatory cases, agency officials who serve as investigator, prosecutor or advocate are barred by law from participation in the decisions. And Commissioner Cox, the association said, performed these roles while serving as chief of the Broadcast Bureau before his appointment to the commission last March.

Sangamon Case Cited ■ AMST relied heavily on the Sangamon Valley case, which involved the transfer of a VHF channel from Springfield, Ill., to St. Louis. In remanding the case to the commission, because ex parte representations had been made to individual commissioners, the U. S. Court of Appeals held that, in deciding television allocations matters, the commission should observe standards applicable to adjudicatory proceedings.

ABC and the other opponents of the AMST motion, however, said the drop-in case is rulemaking, not an adjudicatory proceeding. They added that the court, in deciding the Sangamon case, didn't intend to recharacterize all allocations proceedings as adjudicatory. ABC said the court was concerned only with "basic fairness" and didn't hold that the Sangamon case was not a

RADIO STATION FORCED SALE!

See page 79

Hamilton-Landis
G ASSOCIATES, INC.



What's the lowest-cost fully transistorized broadcast VTR*? AMPEX VR-1100

Now: any station can enjoy the advantages of Videotape*—with all the quality of Ampex. Reason: the new Ampex VR-1100—a transistorized broadcast Videotape Television Recorder that costs less than \$35,000. And here's what you get for the price: two speeds—7½ ips and 15 ips; recording time up to 3 hours; compatibility with all 4-head recorders; half the floor space of previous VTRs; half the weight; single camera production capability; low power

*TM Ampex Corp.

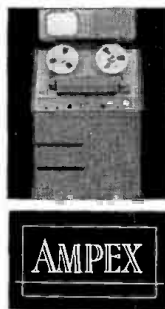

requirements; new convection cooling system; no need for blowers or special air conditioning in the station; minimal controls; low maintenance; superb reliability and performance. It's all in the Ampex tradition. For details on a complete production system, including Marconi 4½-inch image orthicon camera and accessories, call your Ampex representative or write: Ampex Corporation, Redwood City, California. Sales and service offices throughout the world.

Goodbye Conelrad, hello Emergency Broadcast System

Conelrad—the emergency broadcasting system established in 1951 for use in event of war or state of peril or disaster—officially passes into history today (Monday). In its place is the new Emergency Broadcast System.

The FCC last week noted the occasion by expressing its “gratitude” to the Conelrad stations that voluntarily “contributed their time, effort and money to the success” of that system. The commission also praised the stations outside the system that participated in the Conelrad tests over the years.

The new system was devised by a special committee of the National Industry Advisory Committee. The commission last month adopted rules providing for the new procedures after consultation with the Defense Department’s Office of Civilian Defense and the Office of Emergency Planning (BROADCASTING, July 8).

Under EBS, all stations wishing to participate and meeting NIAC requirements will ultimately be authorized to remain on the air in a national emergency. Initially, only the 1,400 AM and 200 FM stations now holding interim National Defense Emergency Authorization from

the FCC will be permitted to do so. The interim authority extends from today to Dec. 31. In the meantime, civilian defense officials, working with Commissioner Robert T. Bartley and commission engineers, will determine local and regional originating points.

Aim Of System ■ The object of the new system, the FCC says, is to fulfill national security requirements while providing for transmission of vital information to the public.

Stations remaining on the air during an emergency will not be permitted to use their call letters (to prevent broadcasters from benefiting competitively) and will be required to follow this order of broadcasting priority: presidential messages, local programs, state or regional programs, and national news and information.

Under Conelrad, only authorized stations broadcasting on 640 kc or 1240 kc were allowed to remain on the air during an emergency.

New Rules ■ Meanwhile, the FCC last week announced the adoption of new rules providing for an internal reorganization of the agency to enable it to carry out its responsibility for planning for nongovern-

ment communications in time of emergency. The commission was given this function by President Kennedy in an Executive Order last spring.

The commission took the first step in this connection in May, when it organized an Office of Emergency Communications. The new rules put the office under the supervision of Curtis B. Plummer, the commission’s executive director. He, in turn, will be subject to the general direction of FCC Defense Commissioner Bartley.

The new office is charged with preparing emergency plans covering service by broadcasters, common carriers and safety and special radio operators; assignment of radio frequencies to licensees under national emergency conditions, and protection, maintenance and restoration of communications facilities.

These plans are to be designed to develop a state of readiness in these areas “with respect to all conditions of national emergency, including an attack upon the United States.” The plans are to take into account the possibility of “exclusive government use or control of communications services or facilities, when authorized by law.”

rulemaking matter.

The petitioners also maintained that, even if the case were classified adjudicatory, Commissioner Cox needn’t be barred from participating. They said that, as chief of the Broadcast Bureau, he did not, as AMST claimed, act as investigator, prosecutor and advocate.

ABC said his function was not to “ferret out facts” or try “to win a case.” The network said staff members “are not partisan advocates: their perspective is identical with that of the commission itself, to decide in the public interest.”

The petitioners also disputed AMST’s contention that Commissioner Cox’s participation would be incompatible with “basic fairness.” They cited AMST’s assertion in its motion that it doesn’t question the commissioner’s integrity or “inherent impartiality.”

‘Caesar’s Wife’ Approach ■ ABC said the commission conducts allocations proceedings in “accordance with basic fairness” but that AMST is, in effect, requiring that the agency adopt a “‘Caesar’s wife’” approach “which would immobilize the commission in the vital allocations area.”

“To meet AMST’s proposed standard (a total ‘lack of prior connection with the merits’ of the case),” ABC said, the association “would no doubt expect Commissioner Lee, chairman of the Committee for the Full Development of All Channel Broadcasting, to disqualify himself because of his important efforts to promote UHF when, as here, the decisional basis for the commission’s action turning down the drop-ins was predicated upon a belief as to their effect on UHF growth.”

ABC also maintained that the AMST motion should be dismissed because it isn’t “timely.” The network noted the proposal was filed 47 days after the May 29 vote on the drop-ins and two weeks after Commissioner Cox issued his dissent. AMST said it waited as long as it did because it didn’t believe Commissioner Cox would participate in the decision.

But, ABC said, there were reports in the trade press preceding the vote that Commissioner Cox would participate. In addition, the network said, the commissioner’s votes in other matters on which he had worked as Broadcast Bu-

reau chief indicated he would not abstain.

ABC said it was concerned with timeliness only because the timetable of events “exposes the opportunistic and insincere quality” of AMST’s motion. If the association were concerned about the public interest, ABC said, it wouldn’t “have held its peace” so long.

Besides ABC, those filing oppositions to the AMST motion and the markets in which they hope to apply for VHF drop-ins are: Buckeye Broadcasting, Megacity TV Inc. and Gem City TV, all Dayton; Charlotte Telecasters Inc., Charlotte; Community First Corp., New Horizons Telecasting Corp. and Brennan Broadcasting Co. (WAPE), all Jacksonville; Magic City TV Corp., Birmingham, and Rivoli Realty Co., permittee of WARD-TV (ch. 56), Johnstown.

‘Thought control’ seen in FCC ad time limits

FCC rules limiting the amount of time stations could devote to commercials would be the first step toward government “thought control” over radio and TV, an executive of the Na-

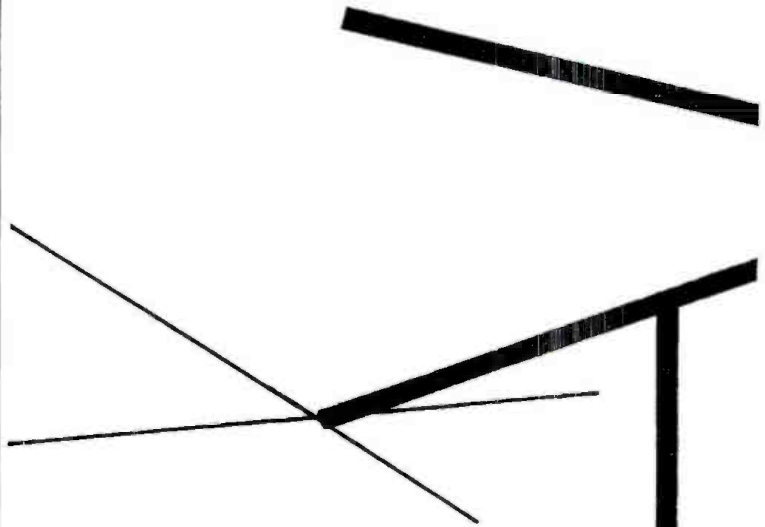
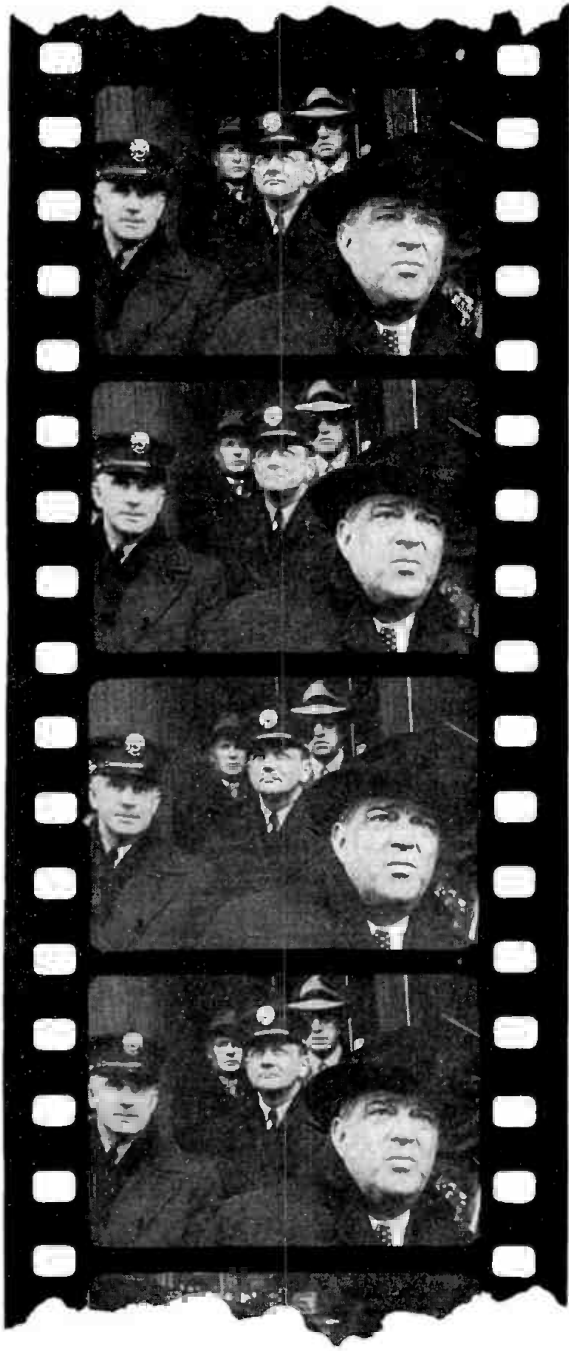

BIOGRAPHY

...one of 268
syndicated
TV film series
which use*

BMI

*licensed music
and were
telecast locally
during the past year*

*out of a total of 390
syndicated TV film series

BMI

*

BROADCAST MUSIC, INC.

589 FIFTH AVENUE • NEW YORK 17, NEW YORK

CHICAGO • LOS ANGELES • NASHVILLE • TORONTO • MONTREAL

Western Electric in Omaha: behind the scenes of telephone progress

America's need for communications continues to grow.

Helping to meet this need are the communications products made at Western Electric's Omaha Works. Included are cable, wire, "crossbar" switches and wire spring relays for central offices. These and other high-quality products are manufactured at the Omaha Works and assembled into completed switching units essential to the 21 Bell telephone companies across the nation.

It takes more than 4,500 people from the Omaha area with a wide variety of skills to do this important work for

the Bell System. During 1962, these Omaha Works employees earned more than \$26 million in salaries. In addition, Nebraska benefited from some \$8.9 million worth of goods and services purchased by Western Electric from 435 suppliers, most of them small businesses.

The Omaha Works is just one of 13 major Western Electric manufacturing plants, all producing essential communications equipment needed by the Bell telephone companies to provide you with the finest telephone service at the lowest possible cost.

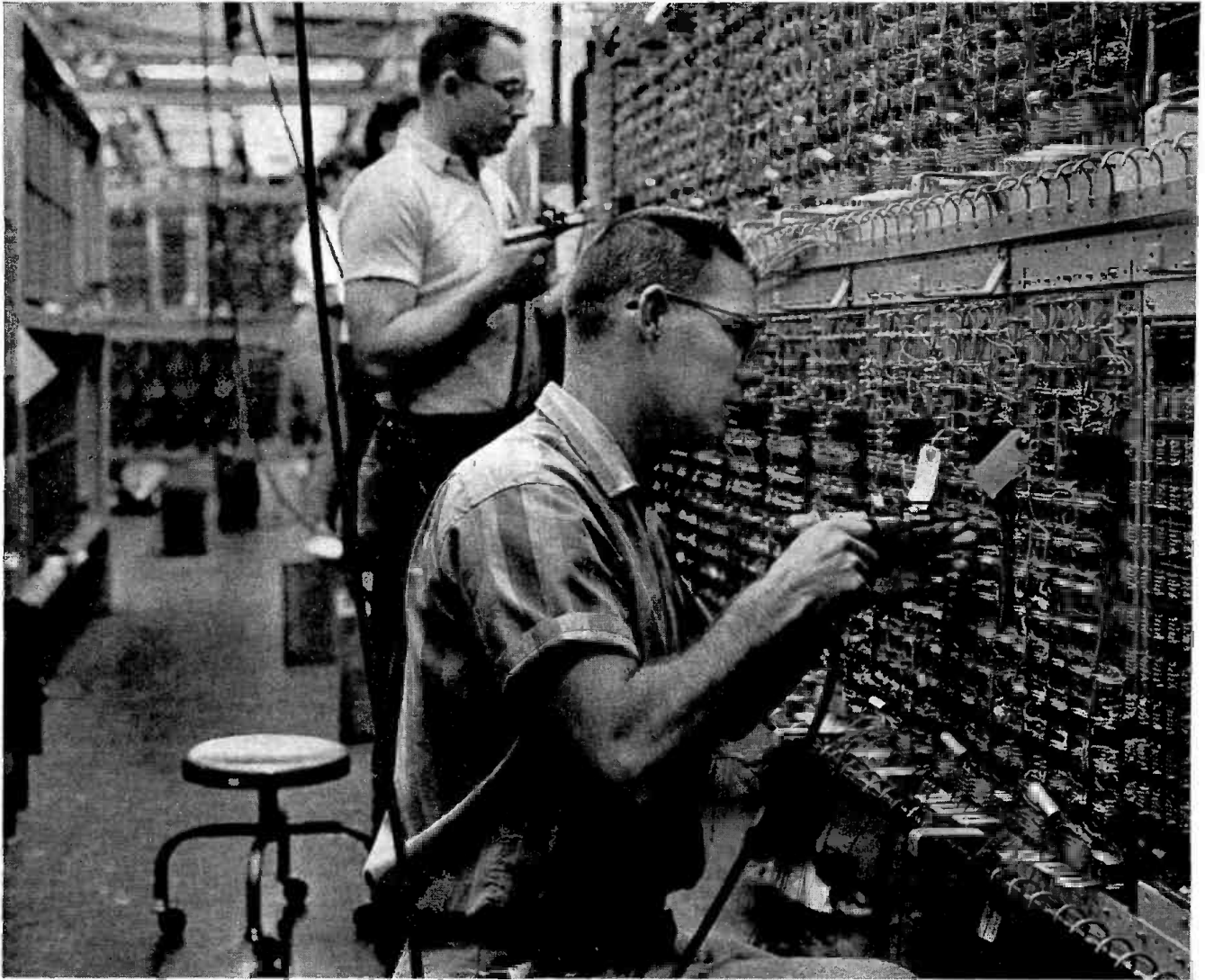

Huge Frames for central office equipment are rapidly equipped with Omaha Works-produced switches and cable with the help of wire-wrapping guns. Above, Wiremen Delmer Kyles (foreground) and Fred Dady work on one of these units. Designed by Bell Telephone Laboratories and manufactured and installed to exacting specifications by W. E., these switching units are used by Northwestern Bell and the 20 other Bell telephone companies to connect telephone calls quickly and efficiently.

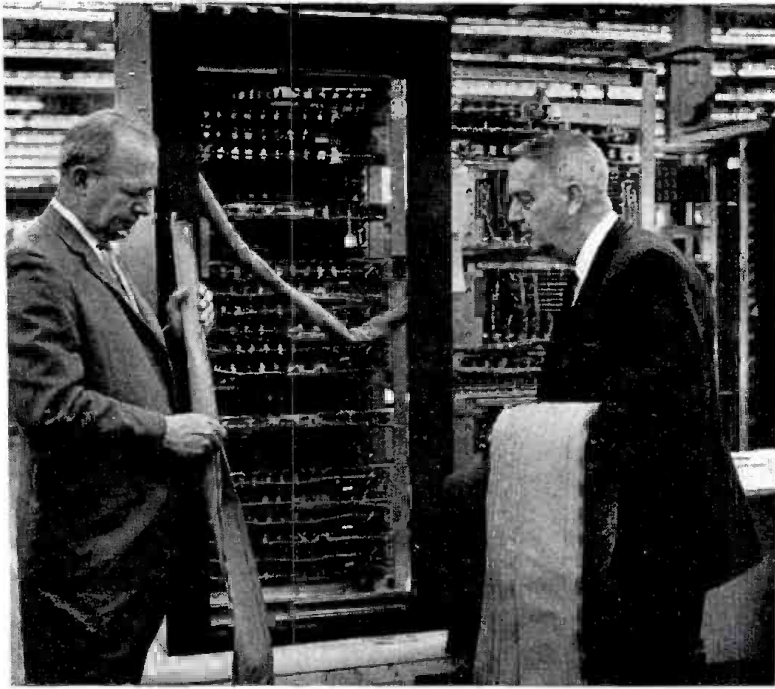

Canvas Cable Covers are used to protect cabled wire from dirt or injury in "PBX" switching units. The covers are supplied to the Omaha Works by Jorgensen Awning Inc., a local company. President Leo D. Jorgensen (left) discusses his firm's product with W. E. Buyer Jim Farnsworth. This company is one of more than 40,000 located in all 50 states from which Western Electric purchased \$1.2 billion in goods and services last year.

Omaha World-Herald President and Editor W. E. Christensen says: "In the four years Western Electric has been here, the company has proved itself to be an outstandingly fine citizen. Many local businesses have benefited through the things they sell to Western Electric. And W. E. people are truly community-minded . . . they are a part of every phase of community and civic life."



Thousands of Items are shipped daily from Western Electric's recently opened Omaha Distribution Center. There is a total of 35 strategically located W. E. centers which supply the Bell telephone companies with a vast variety of communications products. In emergencies, W. E. people are ready to deliver around the clock.

Plant Tour for State Legislature attracted many prominent Nebraska citizens. Here, part of the group learns about the coil-winding machine, an important step in the production of crossbar switches. Left to right are Mrs. William H. Farley and Mr. Farley, head of Western Electric's Area Installation Office in Omaha, State Senator Richard Lysinger, Omaha Works Comptroller Wyllys E. Rheingrover and Edward Danner, State Senator from Omaha.



tional Association of Broadcasters said last week.

John Couric, NAB director of public relations, said the FCC's proposed rulemaking to adopt the industry's own voluntary time standards constitutes a federal intrusion into free broadcasting. The commission, he said, seeks to create the impression that it would be helping the broadcaster and his audience through mandatory time standards.

The end result, he told a meeting of Georgia school leaders at the University of Georgia in Athens, would be quite different. "Federal control of business practices in broadcasting would not assure improvement of the quality of commercials," he said, "nor would it encourage broadcasters to produce better programming through self-regulation. . . . [It] would destroy free enterprise in broadcasting and would cause damage to advertisers and consumers by sharply curtailing the services broadcasting offers the public."

Members of the public, lacking facts on the dispute, might favor the proposed FCC rule, Mr. Couric said. But, he said, it "would open the door to possible control of programming by the government. And government program control is only a step away from thought control."

Snail's pace in space? FCC thinks so

COMSAT'S DELAY IN OFFERING STOCK CHIEF CONCERN

The FCC and the infant Communications Satellite Corp. have become engaged in a controversy over the company's progress—or lack of it—in establishing a worldwide satellite system for transmitting television, radio, telephone and telegraph communications.

The commission says the incorporators appointed by the President are moving too slowly in making the initial stock offering and are making decisions that should be left to the directors who will operate the corporation once the stock is sold.

The commission expressed its feelings in a letter to Leo D. Welch, chairman of the corporation that was created by Congress last year. Congress placed the corporation under the regulatory authority of the FCC.

Mr. Welch said the facts provide "no basis" for concern by the commission. He said the initial stock offering will be made at "as early a date as the directors determine to be compatible with the public interest and the carrying out of the purposes of the act."

He said it is essential that the corporation make a number of "determinations with respect to the program to be

followed" in order to provide prospective investors with "adequate information in conformity with federal and state securities laws."

He also said the corporation is preparing a summary of its position, "as previously outlined to the commission," for transmittal to the agency.

The commission noted that the corporation in February indicated that the initial stock offering would be made this year. But, the letter added, the FCC is now "disturbed by current indications that the corporation no longer has definite plans for an early issue of stock."

The agency said the corporation is apparently delaying the issue until more development work is done and decisions are reached concerning "the character and scope" of investment by foreign interests.

The FCC said that Congress intended many of these decisions to be left to the "balanced representative body" that will ultimately run the corporation—six directors elected by public investors, six elected by stock-owning communications common carriers and three appointed by the President and confirmed by the Senate.

The controversy came to light in connection with the corporation's request for authority to borrow \$600,000, in addition to a \$500,000 loan authorized in February. The FCC approved the request, but said it probably wouldn't authorize more credit until definite plans for a stock issue were made.

More ETV applications

The Department of Health Education and Welfare has accepted two additional applications for federal funds appropriated by Congress to be used by educational TV stations. The latest applications raise to 14 the number pending with the department, seeking a total of \$2.6 million.

San Mateo, Calif., Junior College has asked for \$122,991 from the government to build a new channel 14 station in San Mateo. The University of Georgia applied for \$136,110 to expand the facilities of WGTV(TV) (ch. 8) Athens, Ga. Copies of all 14 pending applications are open to the public in the HEW offices of the director for educational TV, Washington.

Stations DO Have Personality



LES BIEDERMAN, PRESIDENT

ENTHUSIASM -- That's the keynote of OUR Les Biederman, up to his neck in an eager, very vocal push for civic improvements and growth of Northern Michigan.

Les starts campaigning and the public (most of it) joyfully joins in.

The enthusiasm boiling out of this man reflects in his stations. It is an enthusiasm that sells YOUR product.

STATISTIC -- The Northern Michigan Grade B Area of WPBN-TV and WTOM-TV lists annual drug sales of \$20,825,000.

The PAUL BUNYAN STATIONS

WPBN-TV WTOM-TV WTCM WMBN WATT WATC WATZ

Soren H. Munkhof, Gen. Mgr.

Paul Bunyan Bldg., Traverse City

Nat. Rep. - Venard, Torbet and McConnell -- Network Rep. - Elisabeth Beckjorden

**RADIO STATION
FORCED SALE!**

See page 79

Hamilton-Landis
& ASSOCIATES, INC.

TRUCKS KEEP AMERICA IN HIGH GEAR!!!

Day and night, coast to coast, over the greatest network of highways in the world, trucks—more than 12,000,000 of them—keep America in high gear as they stock its production lines, haul away its finished products, keep its people fed, clothed, and supplied with the necessities and luxuries of life.

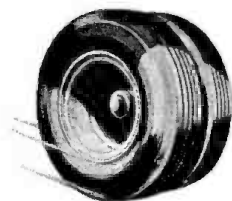
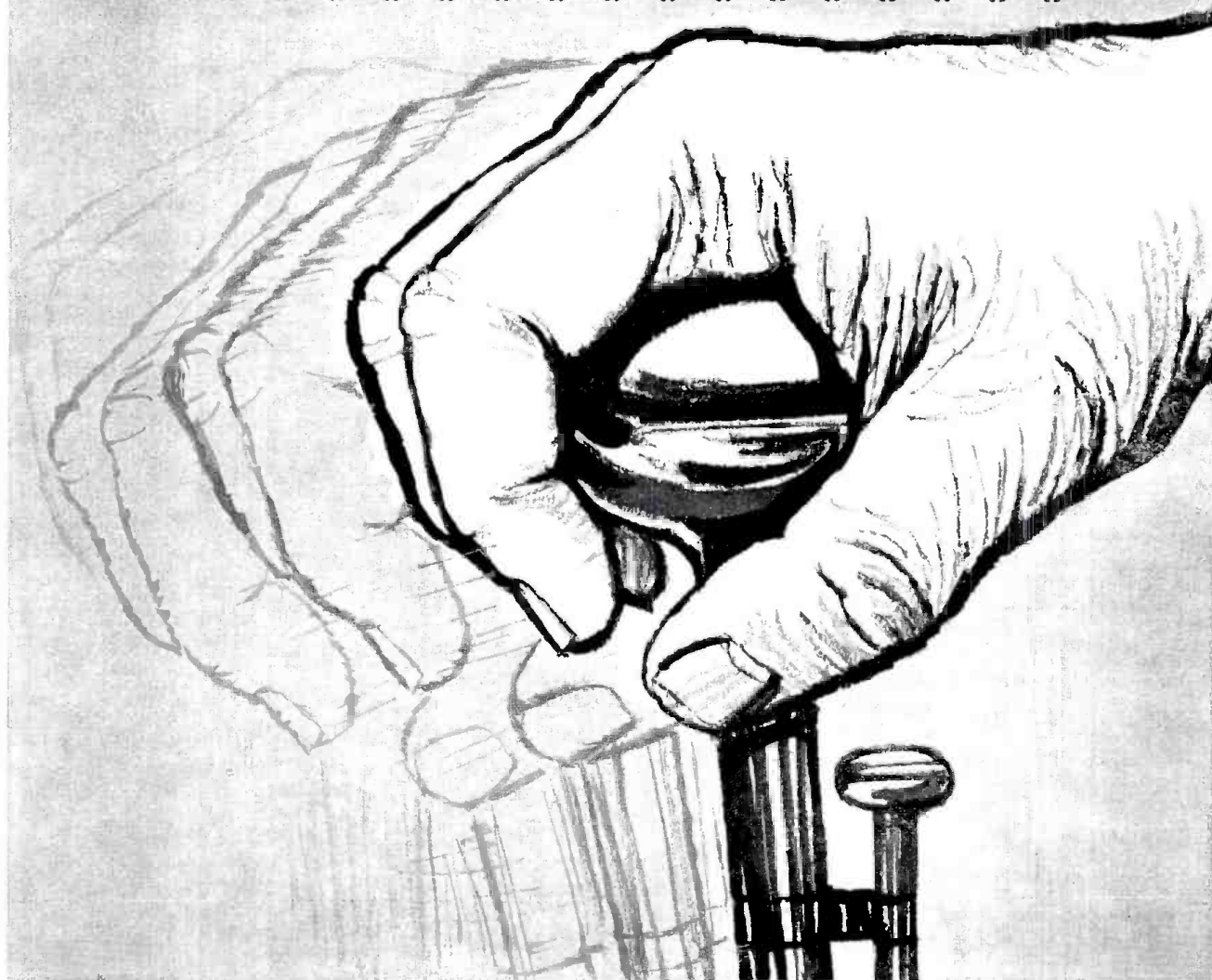

AMERICAN TRUCKING INDUSTRY

THE WHEELS THAT GO EVERYWHERE

American Trucking Associations, Inc. • Washington 6, D. C.



QXR to abandon FM relay system

SOUND QUALITY TROUBLES FORCE SWITCH TO TAPE

Difficulties in maintaining high sound qualities on its direct broadcasts to 16 inter-connected affiliates last week forced the QXR Network to plan abandonment of its present live-broadcast system.

Following a meeting of New York state affiliates in Syracuse, July 30, James Sondheim, network president, announced that QXR will adopt a uniform tape distribution for all of its programs starting Sept. 1. He attributed the changeover to the growing importance of stereo broadcasting and the need to improve transmission quality in the New York-New England area.

Currently 16 of the network's affiliates—located in the New York-New England area, are interconnected by air relays to exchange on-the-air broadcasts. Transmission difficulties caused by interference in the New England area and heavy construction work in New York City have caused network officials to become concerned over sound quality, especially with the increased use of stereo broadcasts.

The rest of the network's affiliates,

some 45 located in QXR's western division, already receive their programming via tape.

Also discussed at the Syracuse meeting were plans for the origination of QXR type on-the-air programming from a point in upstate New York for the use of New York State affiliates, with further possibility that an organization for New England points might be established in Southern New England.

A network official said there were other alternatives being discussed also, and that the network expected to reach a decision within a week.

Hurleigh describes news as aid, not competitor

Increasing numbers of radio station managers are coming to understand network news services as "aids" rather than "competitors."

Robert F. Hurleigh, president of Mutual, takes this position in the August newsletter distributed by that network. He says station licensees now realize that quick distribution of global

information is not only necessary in maintaining adequate service but a requisite for "survival."

Mr. Hurleigh states that the speed required today in disseminating world news requires "such a complex of manpower and facilities that no one station and no single group-owned combine can adequately manage it alone." He suggests that a network news service such as Mutual's is no more disruptive to a station's unique personality "than a piece of AP copy on page one" of a newspaper.

He foresees a day when networks will supply not only national and international news under the "exclusivity formulas" they now use but also will syndicate different correspondents to multiple stations within a single market. He sees closer network-station ties developing with the introduction of such new contractual arrangements.

Changing hands

ANNOUNCED ■ *The following sale of station interests was reported last week subject to FCC approval:*

■ **WINF-AM-FM** Manchester, Conn.: Sold by John Deme, who recently bought **KAVE-AM-TV** Carlsbad, N.M. (BROADCASTING, June 24), to Profit Research Inc., New York, for \$285,000. President of Profit Research, business publishing firm, is Sidney Walton. **WINF** is a CBS-affiliated fulltime station on 1230 kc with 1 kw daytime and 250 w at night. The FM outlet is on 107.9 mc with power of 7.6 kw. Broker: Blackburn & Co.

APPROVED ■ *The following transfers of station interests were among those approved by the FCC last week (for other commission activities see FOR THE RECORD, page 95).*

■ **KKTV(TV)** and **KFMH(FM)** Colorado Springs and **KGHF** Pueblo, Colo.: Sold by James D. Russell, Betty Z. Russell, Robert D. Ellis and Clifford Phillips to Communications Systems Inc. for \$885,000 and a five-year agreement not to compete. Willard W. Garvey, president of Communications Systems, and his family have minority interests in several stations. **KKTV** (ch. 11) is affiliated with CBS-TV. **KFMH** is on 96.5 kc with power of 23 kw and **KGHF**, affiliated with ABC and Intermountain Network, is on 1350 kc, 5 kw day and 1 kw night.

■ **WBSM-AM-FM** New Bedford, Mass.: Sold by the estate of Joseph P. Duchaine to George Gray and Murray Carpenter for \$395,000. Mr. Gray is past general manager of **WORL** Boston and Mr. Carpenter founded **WABI-TV** and **WPOR**, both Portland, Me. The AM is on 1420 kc with a power of 5 kw day and 1 kw night, and the FM

Outstanding Values in Radio-TV Properties

We currently have a limited number of radio stations for sale in California, Arizona, Nevada, Oregon, Washington, Utah, Montana, Hawaii and Alaska . . . large, medium and small markets . . . solid growth areas.

Contact Mr. Colin M. Selph or Mr. Bennett Larson in Beverly Hills or any Blackburn office.

**PACIFIC
COAST**
FAR WEST
\$60,000
to
\$1,000,000

BLACKBURN & Company, Inc.

RADIO • TV • CATV • NEWSPAPER BROKERS
NEGOTIATIONS • FINANCING • APPRAISALS

WASHINGTON, D.C.

James W. Blackburn
Jack V. Harvey
Joseph M. Sitrick
RCA Building
Federal 3-9270

CHICAGO

H. W. Cassill
William B. Ryan
Hub Jackson
333 N. Michigan Ave.
Chicago, Illinois
Financial 6-6460

ATLANTA

Clifford B. Marshall
Stanley Whitaker
John G. Williams
1102 Healey Bldg.
Jackson 5-1576

BEVERLY HILLS

Colin M. Selph
G. Bennett Larson
Bank of Amer. Bldg.
9465 Wilshire Blvd.
Beverly Hills, Calif.
CRestview 4-8151

outlet is on 97.3 mc, 2.5 kw. Broker: Blackburn & Co.

▪ WHRV Ann Arbor, Mich.: Sold by Zanesville Publishing Co. to Radio Ann Arbor Inc., whose principal owner is Frank H. Babcock, for \$295,000. Zanesville Publishing, which publishes the *Zanesville (Ohio) Times-Recorder* and *Signal*, controls WHIZ-AM-TV Zanesville and WTAP-AM-TV Parkersburg, W. Va. WHRV is a fulltimer on 1600 kc with power of 1 kw. Broker: Hamilton-Landis & Associates.

▪ WGTC-AM-FM Greenville, N. C.: Sold by A. W. Lewin to Roy H. Park for \$116,885. Mr. Park owns WNCT(TV) Greenville and one-third of WECT(TV) Wilmington, N. C. WGTC, a CBS station, is on 1590 kc, 5 kw day and 1 kw night. WGTC-FM is on 107.7 mc with 20 kw.

▪ KOKE Austin, Tex.: Sold by Giles E. Miller to David R. Worley for \$110,000. Mr. Miller is also selling his interest in KPNC Grand Prairie and KBUY Amarillo, both Texas (see page 96). Mr. Worley owns KLEA Lovington, N. M., and 50% of KWBA Baytown, Tex. KOKE is a 1 kw daytimer on 1370 kc. Broker: Hamilton-Landis & Associates.

Liston-Patterson fight had 55 million listeners

The championship heavyweight fight between Sonny Liston and Floyd Patterson July 22, carried by ABC Radio attracted a listening audience in excess of 55.5 million.

According to a special report issued by Sindlinger & Co., 36,608,000 males and 19,066,000 females tuned in to the one-round match. Pre-fight estimates by the network put the potential audience at more than 50 million.

Sponsors of the broadcast were Pontiac Motor Division of General Motors Corp., Wynn Friction Proofing, General Cigar Co. and the Mennen Co.

Hoffa files new libel suit

Teamsters Union President James R. Hoffa filed a new \$10 million libel suit against NBC last Tuesday (July 30) in Detroit. The suit cites two appearances by Attorney General Robert Kennedy on the *Jack Paar Show* July 22, 1959, and *Meet the Press* on July 26, 1959 as two dates on which the labor leader was allegedly libeled.

Mr. Hoffa's right to sue NBC in Michigan was upheld in the U. S. District Court in March (BROADCASTING, March 11). His original suit for \$2.5 million was also based on the Kennedy appearances.

BROADCASTING, August 5, 1963



Toast to the tower

WTRF-TV Wheeling, W. Va. has celebrated the installation of its new television tower by feting more than 400 advertising and agency personnel at two Tower Topper parties in New York. Included in the presentation was a 30-minute film to acquaint the viewers with new coverage area afforded by the tower. The tower has been increased from 590 feet to 962 feet above average terrain.

Robert Ferguson, WTRF-TV executive vice president (l), and Henry Cleeff, Ogilvy, Benson and Mather, New York, use Tower Toasters at the channel 7 celebration.

Media notes . . .

Down on the farm ■ Jay Gould, wowo Fort Wayne, Ind. farm service director, has written a booklet, available from the station, which outlines the relationship between farms and broadcasting. Called "Evaluation of Modern Farm Broadcasting," the booklet gives Mr. Gould's views on farm radio listening.

Target date ■ Oct. 1 has been set as the target date for the opening of WGHP-TV High Point, N. C. The station will be a primary affiliate of ABC-TV.

Rock around the clock ■ WJLD Home-wood, Ala., is extending its broadcast day to 24 hours with the addition of an all-night music, news and weather show.

CATV's role in aiding ETV

The National Community Antenna TV Association is planning a survey on the extent to which community antenna television systems are furthering the signals of educational TV stations, NCTA President William Dalton said last week.

In a letter to FCC Chairman E. William Henry, Mr. Dalton pointed out that of 70 ETV stations in areas

FORCED SALE!

We represent a radio station owner, who, due to regulations of the Federal Communications Commission, will have to divest himself of his seventh station in order to acquire a larger market facility which he has arranged to purchase through Hamilton-Landis & Associates, Inc.

The station being sold is located in the east and in one of the top 65 markets of America. It has a cash flow of between \$65,000.00 and \$70,000.00 for each of the past two years.

It carries a firm price of \$400,000.00 on the basis of 29% down and the balance out over five years bearing six per cent interest. Details will be furnished immediately to all qualified buyers.

Contact—Ray V. Hamilton in our Washington, D. C. office, or the Hamilton-Landis & Associates office nearest you.

Hamilton-Landis

& ASSOCIATES, INC.

John F. Hardesty, President

NEGOTIATIONS • APPRAISALS • FINANCING OF CHOICE PROPERTIES

WASHINGTON, D.C.

1737 DeSales St., N.W.
Executive 3-3456

CHICAGO

Tribune Tower
DElaware 7-2754

DALLAS

1511 Bryan St.
Riverside 8-1175

SAN FRANCISCO

111 Sutter St.
EXbrook 2-5671

RADIO • TV • CATV • NEWSPAPERS

America's Most Experienced Media Brokers

Collins likes British commercials

LeRoy Collins, president of the National Association of Broadcasters, returned to Washington last week from a month in England with praise for the placement and quality of commercials on English television.

"I think our broadcasters could learn considerably from British commercial TV in that respect," Governor Collins said. He said the Independent TV Authority, the commercial network in England, does a "remarkably good job" with its commercials.

There is much to recommend the British system of confining commercials to blocks at "natural" breaks in programming, he said. This minimizes the number of interruptions which cause agitation in the U. S., Governor Collins said.

He explained, however, that he was not advocating divorcement of American television advertisers from direct program sponsorship. An advertiser who wants to buy an entire program, and gain identification with

that show, should be permitted to do so as long as the broadcaster retains control of the content, he said.

The quality of English-produced TV programs is very good, Governor Collins said, but "I was amazed at the lack of quantity." He pointed out the British producers are freed to use words and subjects that are taboo in this country. If British producers are to achieve their desires to export more TV programs to the U. S., they would have to change some of their productions before they would be acceptable here, he said.

English TV is not as basic a part of the British way of life as television is in America, he said. Broadcasters in England "just don't pretend to give the overall benefits to the public that we do," he said. Governor Collins attributed this to the fact British radio-TV were developed originally under the government-chartered BBC while America's is a free enterprise system.

served by CATV systems, 56 are duplicated by the CATV. "The CATV industry has made significant contributions to the nation's schools in bringing the signals of ETV stations to communities which would otherwise be without educational television," Mr. Dalton said.

Broadcasters' meeting on GOP arrangements

Representatives of broadcasters planning to cover the 1964 Republican National Convention are meeting today (Monday) and tomorrow in San Francisco, site of next year's GOP gathering.

The Republican arrangements committee will guide newsmen through the Cow Palace, which is the convention

hall, and hear their requests for floor space, housing accommodations and parking. The committee will consider media requests in an executive session on Wednesday.

Robert L. Pierce, GOP national committeeman from Wisconsin (Menominee), is vice chairman of the arrangements committee, and Robert R. Snodgrass, national committeeman from Georgia (Atlanta), is chairman of the subcommittee on radio and television.

The man expected to handle similar media arrangements for the Democratic Convention in Atlantic City is also from Atlanta. J. Leonard Reinsch, executive director of the Cox stations, was Democratic convention manager in 1960 and already has worked with the site com-

mittee in preparation for 1964.

The Democrats will meet officially with representatives of the news media at their convention site in late September or early October. However, because the networks and wire services usually require the major share of work space, they'll meet informally with Democratic arrangements people in Atlantic City Aug. 21 and 22.

Bill Henry, veteran Washington newsmen, is chairman of the 1964 convention arrangements committee for radio and television, and will be responsible for much of the detail work involved in setting up facilities for broadcasters.

WBT expanding studios for new production firm

A \$500,000 expansion of the studios of WBT-AM-FM and WBT(TV) Charlotte N. C., has been announced by Jefferson Standard Broadcasting Co. The expanded facilities will accommodate Jefferson Productions, which will specialize in commercial production and program syndication for both radio and television.

Charles H. Crutchfield, Jefferson Standard Broadcasting president, announced that Jefferson Productions will serve networks, agencies, advertisers and other broadcast stations. It will also handle the company's own syndicated efforts, such as *Radio Moscow* and the *Arthur Smith Show*. The Smith program, a half-hour show, is now syndicated in 13 markets.

John P. Dillon, formerly promoter manager for WBT(TV), has been named sales manager of Jefferson Productions. and James R. Rogers, WBT's commercial coordinator, will be production coordinator.

Wallace Jorgenson, vice-president and managing director of WBT(TV), and Paul B. Marion, WBT assistant vice president and managing director, will supervise the operation of Jefferson Productions.

FINANCIAL REPORTS

Stockholder protests heard at Seven Arts

Minority stockholders of Seven Arts Productions Ltd., attacked the company's management at the annual meeting last week for buying a 20% interest in Grand Bahama Development Co. on Grand Bahama Island.

The complaining stockholders charged that Seven Arts' management failed to make "full disclosure" about the \$5-million purchase.

A conflict of interest was alleged because Louis Chesler, Seven Arts chairman, also owns an interest in the land development company. Mr. Chesler

conceded he had urged the Seven Arts board to make the Grand Bahamas investment because he thought it would be a good thing for Seven Arts. It was announced he had offered to sell his \$2 million investment in Grand Bahama Development, but that the Seven Arts board had turned down the offer.

The full management slate of directors was elected, but a group of dissident stockholders polled over 25% of the shares.

Seven Arts Productions Ltd. produces motion pictures, and through a subsidiary company, Seven Arts Associated Corp., distributes motion pictures to TV. The meeting was in Toronto.

3M second quarter hits high on sales, earnings

Record second quarter sales and earnings were reported last week by the Minnesota Mining & Manufacturing Co., and the company predicted third-quarter figures also would show increases. 3M Co. owns MBS and makes Scotch brand broadcast tapes among many other products.

Three months ended June 30:

	1963		1962	
Earned per share	\$	0.43	\$	0.38
Net sales	190,177,942.00		172,826,699.00	
Total income	191,688,827.00		174,003,649.00	
Total costs, expenses				
including taxes	169,235,764.00		154,228,041.00	
Net income	22,453,063.00		19,775,608.00	

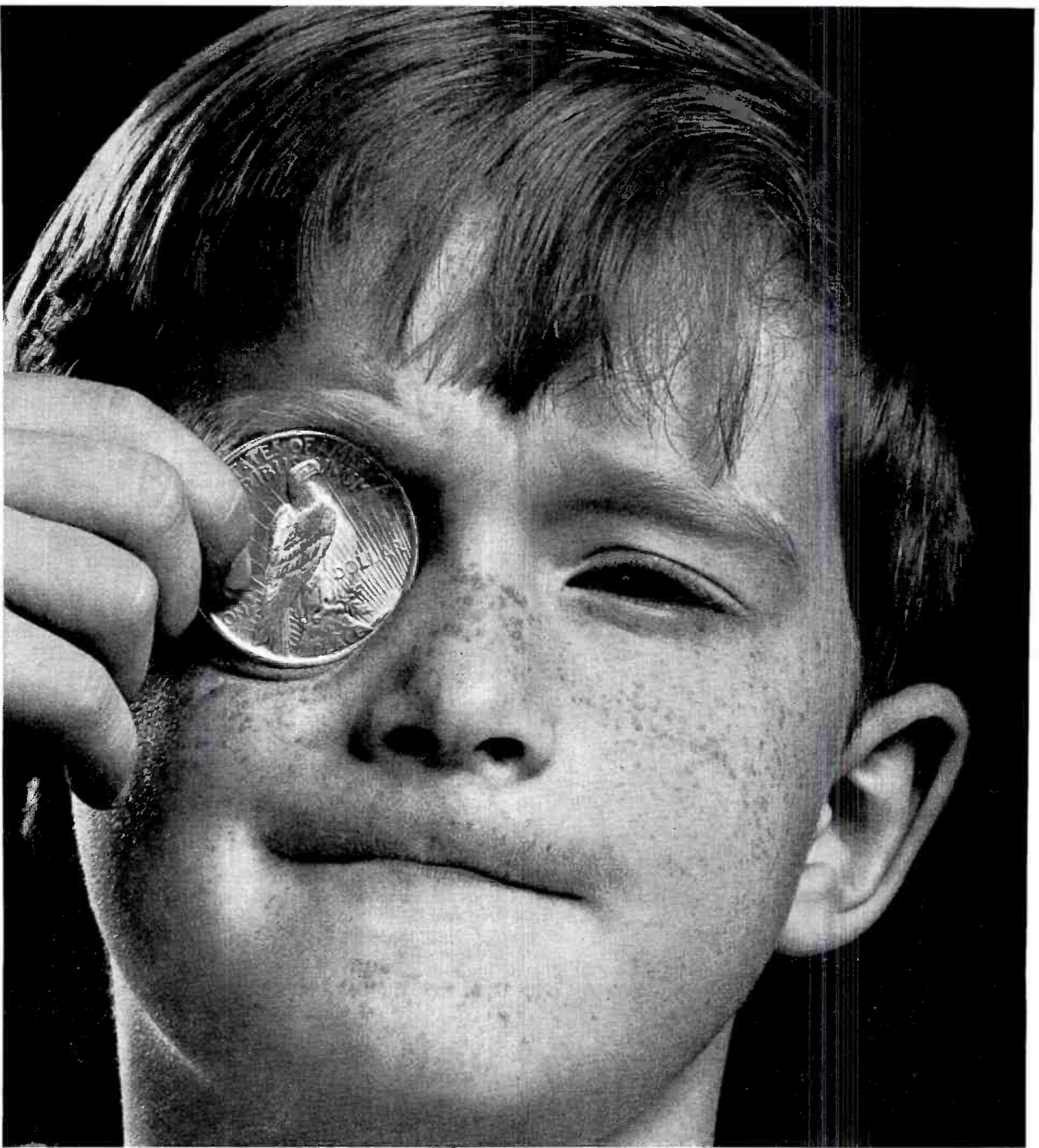

Multiply by 5½ billion, and what do you get?

You get a rough idea of how many of our tax dollars have already gone into electric power systems owned and run by the federal government. And that's quite an eyeful of silver dollars.

Some people want our federal government to get even deeper into the power business. They want it to spend billions more of your tax dollars for

federally owned electric systems, even though they are not needed.

The fact is investor-owned electric power companies are already planning and building to supply all the additional electricity you—and all America—will need to keep the future bright. They are companies *you* built, because you have supported them as customers—

perhaps as a shareholder, too. For these are local companies owned by millions of investors, by millions of people like you.

When you think of all this, do you see any reason for the federal government to spend your taxes on more federally owned power systems—a job it doesn't have to do?

Investor-Owned Electric Light and Power Companies ... owned by more than 4,000,000 shareholders across the nation
Sponsors' names on request through this magazine

'International Hour'—a project in goodwill

Ironing out the problems of an international television program exchange among 12 countries is no mean task. Now in their third summer as participants in such an exchange, the CBS-owned TV stations are still having this lesson brought home to them, but evidently they feel the rewards of presenting their sustaining *International Hour* outweigh the expenses involved.

The stations are presenting 12 such hours this summer and have also made the programs available to WETA-TV, Washington educational outlet.

Although no definite statement has been made, future participation in the exchange by CBS seems assured. Last week Merle Jones, president of the CBS Television Stations Division, told *BROADCASTING* *The International Hour* would continue to be developed to its "fullest potential."

In the summer of 1961 seven countries contributed programs to the CBS stations in return for a series of 13 musical programs, *The American Musical Theater*, produced at WCBS-TV New York.

Growth Story ■ Last summer the exchange developed, from a two-way exchange between the CBS stations and the six other participants, to an exchange among all countries taking part, each contributing one program to the international pool.

This summer 11 foreign broadcasters have joined the program: RAI, Italy; Telesistema Mexicano, Mexico; CBC, Canada; NTS, Netherlands; Telefis Eireann, Ireland; TBS, Japan; Swiss Television Service, Switzerland; NDR, West Germany; Yugoslav Radio-Television,



Argentinita Velez performs in "The History of the Tango," the contribution of Proartel to the international program exchange carried on between the CBS-owned TV stations and broadcasting companies in 11 foreign countries. The "International Hour" program is the last one scheduled in the three years of the international exchange. It will be seen on the CBS-owned stations Aug. 10 and 11 and WETA-TV Washington, Aug. 30.

Yugoslavia; ABC, Australia; and Proartel, Argentina.

Under terms of the project each broadcaster pays only tape shipping costs for the programs. Presentations must be strictly noncommercial; no advertising is allowed within the body of the programs. The sustaining nature of the programs has dictated their placement in weekend afternoon time slots on the CBS-owned stations.

A spokesman for the stations points out that despite the noncommercial flavor of the exchange, foreign broadcasters as well as the CBS stations understand the commercial possibilities suggested by the plan.

Although the language problems presented have been essentially overcome by turning to musical and dance presentation, technical difficulties in the exchange are rife.

Flutter And Sync ■ Most foreign broadcasters operate on more flexible time periods than American stations and some programs received by CBS in the exchange have been as much as 20 minutes over the 58 minutes allocated to the programs by the CBS stations. Splicing problems are compounded by the fact that some of the tapes do not have sync pulses (electronic signals which serve as guides for editing). Another problem is "flutter" which may develop in converting tapes from the European 625-line system for presentation on the American 525-line system. Variations in picture and sound level add further difficulties.

In spite of these headache items *International Hour* has established its niche in the CBS-owned stations regular summer plans.

MORE TIME FOR BEER AND WINE?

Proposed BBG rule would allow 30-second product mention

New regulations to permit more commercials for beer and wine on radio and television programs in Canadian provinces where such advertising is permitted are to be discussed at a public hearing of the Board of Broadcast Governors in Ottawa Aug. 27. BBG has announced proposed new regulations which will permit up to 30-second commercials on the beer or wine product, instead of the present 60-second commercial which permitted only 12 seconds of product identification.

Programs to be sponsored must be at least 10 minutes long and two 30-second commercials will be permitted,

with 10-second billboards. The same number of commercials applies for a 15-minute TV program.

For half-hour Canadian TV programs advertisers may have four 30-second commercials; on non-Canadian programs only three such commercials. On 45-minute Canadian programs five commercials are permitted, four on non-Canadian programs. In the case of 60-and-90-minute Canadian programs commercials are seven and 10 respectively; with non-Canadian programs six and nine, respectively.

On radio, billboard announcements may be 15 seconds and other commer-

cials 30 seconds. One commercial announcement is permitted for a 5-minute program, two for a 10-or-15-minute program, four for a half-hour show, five for a 45-minute show, eight for one-hour program, and 10 for a 90-minute show. Flash and spot announcements are prohibited on both radio and television programs sponsored by breweries or wineries.

Mexican agency reopened

Guastella de Mexico, S. A. advertising agency, has reopened its offices in Mexico City with full services including public relations, sales promotion, research and marketing departments. During his eight-year absence from Mexico City, agency President Mariano Guastella operated agencies in

Spain and Cuba. Among the accounts are Mexican operations of Lady Arrow, Kelvinator, Leonard, Motorola, Super Winchester de Mexico, Lanvin and Supphose. The agency address is Calle de Napoles 49, Mexico City.

Ad revenue deficit halved by CBC

Advertising revenue of the Canadian Broadcasting Corp. for the fiscal year ending March 31, 1963, totaled \$30,846,627, against \$32,910,118 the previous year. The deficit was half that of fiscal 1961.

In the last fiscal year CBC spent \$108,365,882 on programing, selling and administration, up from the previous year's \$107,611,154. CBC's income from commercial programs, interest on investments and grants from Parliament amounted to \$104,057,330, compared with \$103,572,113 the previous year. Depreciation was \$4,308,552 last year and \$4,039,041 in fiscal 1962.

CBC received in addition to its operating grant of \$73,244,000 from Parliament, \$6.6 million for capital expenses.

Cost of programing for fiscal 1963 was broken down as \$63,586,267 for noncommercial programs and \$28,801,732 for sponsored programs. Selling expenses for the commercial division are given as \$7,268,751, up from the previous year's \$6,967,639.

Britain would get color sooner with U. S. system

If the American system is adopted, color television could begin in Britain early in 1965. But a decision in favor of the French or German systems would mean a delay of a year or more. This view has been expressed by F. C. McLean, BBC director of engineering, in reviewing the results of demonstrations in London for European Broadcasting Union delegates.

Opinions of 60 delegates from 20 countries are being collated as part of the process of reaching agreement on a unified European color TV system.

Immediate adoption by Britain and the rest of Europe of the American system has been requested by F. N. Sutherland, deputy chairman and managing director of the Marconi Co. and a new member of the postmaster general's television advisory committee. Speaking to delegates of the EBU in

**RADIO STATION
FORCED SALE!**

See page 79

Hamilton-Landis
6 ASSOCIATES, INC.

Russia's ham problem

Self expression in the Soviet Union may have found a new medium—ham radio. A Russian newspaper, *Lenin's Generation*, published in the Kazakh Soviet Republic has reported increasing problems with ham operators illegally broadcasting "religious programs, vulgar melodies, vacuous conversations and uncensored attacks."

Mentioned specifically were broadcasts by Jehovah's Witnesses from Dzhezkazgan and by Russian Orthodox believers from Alma-Ata.

The newspaper report said the illicit broadcasts were interfering with the government communications system and that in the future stiffer penalties would be meted out to apprehended offenders.

The Kazakh hams, according to the article, make detection difficult by constantly shifting transmitter sites.

London, who have been studying the three rival systems, he said: "As the world's largest exporter of television

transmission equipment I would like to make a plea for worldwide standardization. This can only be effected on the international system which is already in daily use in North and South America and Japan and is also being used for experimental purposes in Russia."

CBC, CTV set schedule for football coverage

Both Canadian Broadcasting Corp. and CTV Television Network Ltd. will carry Canadian Football League games this fall. CBC will broadcast Saturday games and CTV all other games.

CTV started its broadcasts at Calgary, Alberta, on July 31, and CBC will do its first broadcast at Hamilton, Ont., on Aug. 10. CTV has exclusive rights to the western Canadian semi-final games, and the first game of the eastern Canadian finals. The agreement to broadcast the games runs to Jan. 2, 1968.

CBC has as participating sponsors of the Saturday national network broadcasts John Labtt Ltd., London, Ont., (brewers) on the mid-East and Atlantic region stations, and British American Oil Co. Ltd., Toronto, on the full network. The same sponsors and Nabob Foods Ltd., Vancouver, B. C., will advertise on the CTV broadcasts.

BRIGHTEEN
YOUR DIAL!
PROGRAM

"The jerry
smith show"

CUSTOM CUT FOR
YOUR MARKET

"Country Gentlemen" Jerry Smith sings folk music, country music and "pops" the way your listeners like it. Five, 15 minute or half hour shows produced for your market. FOR COMPLETE DETAILS? WRITE:

KEN WELDON

AND ASSOCIATES HOLLYWOOD
1724 W. BUCHANAN PRODUCTIONS
WINTERSET, IOWA

DATELINE: Japan by David Takahara

Television accounts for 22.3% of total ad billings

The four great mass communications media of Japan are newspapers, magazines, radio and television. As a highly literate nation, the Japanese people are avid readers of newspapers and magazines—the printed media for commercial advertisements. Therefore, advertising through the printed media has always been popular.

But in 1961 the percentage of the printed media's share in the total advertising billings of Japan became less than 50% for the first time, while the share of the tele-communications media (radio and television) reached 33.9%, of which TV is 22.3%. The increase of TV billings is very striking: a 38.9% increase over the previous year.

This is even more impressive when one realizes that this year marks only the 10th anniversary of Japanese television. In February 1953, the first television station in Japan was opened in Tokyo. Today Japan's TV industry is flourishing. There are 325 stations and approximately 13 million TV equipped households.

The Japanese viewer spends a great deal of time watching television with Sunday the biggest viewing day. On Sunday the average TV household spends over eight hours at the TV set, almost two hours more than peak periods in the U. S. In the summer months, television viewing does not decrease as much as it does in America.

Because people spend so much time viewing television, a popular Japanese expression which roughly translates "Turn the whole country into a nation of idiots," has achieved notoriety similar to that of the expression "vast wasteland" in America.

Two Systems ■ Unlike the U. S., Japan has both commercial and public television broadcasting. The majority of TV companies in Japan are commercial although NHK (Japan Broadcasting Corp.), supported by fees paid by both radio listening and television

viewing households, is the oldest and largest. There are 212 stations operating under NHK and 114 stations run by 53 commercial companies.

The commercial television industry in Japan has a remarkable record of development. Probably the most important reason for television's rapid progress is the quick recovery of Japanese industry in general, but in addition to the general economic climate of the country, there are several specific reasons for the rapid progress in television—all unique to the Japanese situation.

First was the idea of installing television sets in the streets to demonstrate television to the public and television's potential to the advertiser. This idea was conceived and put into practice by Nippon Television Network Co. (NTV), the first commercial television station in Japan. NTV's first problem was to get advertisers who would sponsor television programs.

In the early days of the medium, however, Japanese advertisers were reluctant to budget large sums of money for television advertising. To overcome this, the station installed large TV screens on the streets of Tokyo. The enormous crowds in the streets eagerly viewing television programs convinced many prospective advertisers that television could be an effective advertising medium.

Another reason for the quick development of television in Japan is the national interest in baseball and Sumo wrestling matches, which provide enormously popular television attractions.

Sales Booster ■ The unprecedented marriage of the Japanese crown prince with a commoner's daughter was one of the events of the century. The anticipated telecasting of the wedding ceremony and parade brought about a phenomenal increase in Japanese television ownership. It is reported that the number of television homes was doubled by

the occasion—from 1 million to 2 million sets.

And last, but quite important, the complex nature of the written Japanese language makes advertisements explaining a new product more difficult to comprehend when written than when heard. For this particular reason both radio and television are more effective than magazines and newspapers from the standpoint of commercial messages, especially in the case of new product introduction.

In the area of research, the industry realizes that comprehensive TV audience research is essential for further development of TV in Japan, because the Japanese public is getting more and more selective about TV programs while companies are adopting more and more rationalized budgeting for TV advertising. As a result of this concern, the Nielsen Television Index Service, established in Japan, has been well received.

No doubt the Japanese TV industry has copied or is still copying a great deal from the TV industry in the United States. One interesting fact is that Japanese TV viewers have been enjoying Japanese dubbed versions of many American programs. For instance, *Laramie*, *Walt Disney Hour*, *Rawhide*, *Bronco*, *Cheyenne*, *The Untouchables*, *Surfside 6*, *Riflemen*, *Ben Casey*, *Lassie*, *Popeye*, *The Jetsons*, *Wyatt Earp*, *M-Squad*, *Combat* and *International Show Time*, to name several, all attract substantial Japanese audiences. If we compare the programs which have been telecast in both countries at present, we can see an interesting picture:

A comparison of ratings for the programs among the U. S. top fifteen which are now showing in Japan:

	U.S.	Japan
<i>Beverly Hillbillies</i>	38.3%	11.8%
<i>Bonanza</i>	31.0	14.0
<i>Gunsmoke</i>	29.6	10.5
<i>Ben Casey</i>	27.9	36.2
<i>Dr. Kildare</i>	27.9	8.5

(Dec. 31-Jan. 13 2-wk. avg. Nielsen Television Index-U.S.) (Dec. 31-Jan. 13 2-wk. avg. Nielsen Television Index-Kanto [Tokyo])

Color TV ■ Another interesting feature of television development in this country is the enthusiasm for color TV which was started in December 1957 by NHK and NTV. At the present time, the United States and Japan are the only two countries that have color television. Only a limited number of Japanese households own color TV sets on account of the high price of

David Y. Takahara, legal representative and client relations manager for A. C. Nielsen Co. in Japan, with headquarters in Tokyo, joined the ratings firm in May 1960. He is a graduate of Hokkaido University in Japan and received a B. S. degree in 1930 from Ohio State University and an M. A. degree from Oberlin College in 1934. Prior to joining Nielsen, Mr. Takahara was liaison advisor for the Japan Steel & Tube Corp.



French island gets shows from Paris

Tapes and records flown in from Paris, two hours daily of local legislative coverage and weather reports: that's the radio diet of the 5,000 residents on St. Pierre. The tiny island-town and its even smaller companion island-town, Miquelon (population 600), are situated off the coast of Newfoundland and are the last French possessions in North America.

Residents get about seven hours of broadcasts daily, with two hours in midafternoon being broadcast from the secretariat of the legislative

council in St. Pierre's main square.

All broadcasting is noncommercial and Governor Jacques Henry told BROADCASTING'S Canadian correspondent that there are no plans for commercial shows or developing local live programs. The colony has no regular newspaper and television reception is intermittent. There are only a few TV sets on the islands and, under favorable conditions, a signal is picked up from CJCB-TV Sydney, N. S., or CJON-TV St. John's, Nfld., both of which are almost 200 miles distant.

color television set at present. But in otel lobbies, railroad station waiting rooms and other public places and lazars, color TV sets are attracting crowds of admirers. In the not too distant future, a color TV set will become a "must" in an average household, because picturesque Japanese scenery, colorful kimonos, etc., are far more effective in color television than lack and white.

In 1964, Japanese television is going to play a very important role as a mass medium for the forthcoming Tokyo Olympics. A powerful relaying system is being planned and a new building for this particular purpose is to be completed by April 1964. If Telstar allows transmission between the United States and Japan for the 1964 Olympic Games, TV in Japan will surely play even a greater role through global televising of this international festival. At the same time, there is no doubt that another spectacular increase of television homes in Japan will follow.

Bevins again defends Lord Hill in Parliament

Britain's postmaster-general, Reginald Bevins, has told the House of Commons that as Lord Hill, formerly Conservative member of Parliament for Charles Hill and minister in charge of government information services, had retired from politics, there could be no objection to his chairmanship of the Independent Television Authority (BROADCASTING, July 15).

Labor MP Donald Chapman had asked if the postmaster-general appreciated the problems created by putting a very active party politician in charge of a public medium of expression of

opinion.

"In times of national crisis, when there may be demands for government statements and opposition counterstatements on matters of the moment, what real assurance can we have that a very active party politician will be utterly impartial in providing the right use of the air?"

Mr. Bevins said he accepted Lord Hill's word that he had retired from politics and said it was quite inconceivable that any ITA chairman would ever attempt to influence either news programs or the TV companies.

Abroad in brief...

Rep appointment ■ CFRA Ottawa, Ont., has appointed Scharf Broadcast Sales Ltd., Vancouver, B. C., as representative in British Columbia and Alberta.

Biggest TV buy ■ Colgate-Palmolive Ltd., Toronto, Ont., has completed the largest single television advertising purchase in Canada by a soap company, with underwriting sponsorship of Canadian Broadcasting Corp. network programs for the coming season on every evening except Thursday. Arrangements were made through Spitzer, Mills and Bates Ltd., Toronto. Colgate-Palmolive will sponsor *Don Messer's Jubilee* (Canadian), *Ben Casey*, *Red River Jamboree* (Canadian), *The Defenders*, *The Saint*, and *Hazel*.

Agency appointment ■ Kotobukiya Ltd., Kyoto, Japan, has named Kenyon & Eckhardt-Novas de Mexico as advertising agency for its wines, whiskeys and liqueurs exported to Mexico.

CHEK-TV sold ■ Sale of CHEK-TV Victoria, B.C., through sale or transfer of shares held by William Rae Jr., David Armstrong and others, to Vantel Broadcasting Co. Ltd., licensee of CHAN-TV Vancouver, B.C., has been approved by the Board of Broadcast Governors, and awaits approval of Transport Minister G. J. McIlraith. Shares of Vantel Broadcasting are being transferred to Saturnia Properties Ltd., Vancouver.

NOTHING LIKE IT IN BROADCASTING—
*anywhere • anytime
anyhow!*

"50-50 CLUB"

in color

on **WLW TV**
and **WLW Radio**
12 NOON-1:30 MON. thru FRI.



*the show with the
Lyons share of talent!*

Ruth Lyons—the modern American Radio-TV phenomenon—has led her smash "50-50 Club" program through its merry paces every weekday at noon for 17 years on WLW Radio and 15 years on WLW Television, the last 6 in color. The show also includes a talented cast, all stars in their own right. Brainy newscaster-lawyer, Peter Grant; vocalists and recording artists—Bob Braun, Ruby Wright, Marian Spelman, Bonnie Lou, with Cliff Lash and his orchestra. Such an array of talent on a local show is certainly unique in broadcasting!

*Another
Crosley Broadcasting Bulls-eye!*

CROSLY COLOR TV NETWORK

WLW-T Television Cincinnati	WLW-D Television Dayton	WLW-C Television Columbus	WLW-I Television Indianapolis
--	--------------------------------------	--	--

WLW Radio—Nation's Highest Fidelity Radio Station

CROSLY BROADCASTING CORPORATION
a subsidiary of **Aereo**

**RADIO STATION
FORCED SALE!**

See page 79

Hamilton-Landis
& ASSOCIATES, INC.

Contest to end contests: turtle watching BUT THERE HAS TO BE A FULL MOON FOR WWIL EVENT

If the late, late shows are any indication, the full moon brings forth nothing more than an assortment of vampires, werewolves, mummies and ghosts. However, in Fort Lauderdale, Fla., under the sponsorship of WWIL, the full moon brings forth thousands of residents and tourists for a "Turtle Watch."

More than 4,000 persons appeared on the Fort Lauderdale beach on the first night of the full moon in July in hopes of seeing a giant sea turtle emerge from the surf, dig a hole in the sand, lay 100-300 eggs, cover them up with sand and return to the sea. The turtles, though, didn't follow the timetable, which calls for them to make an appearance during the full moon in May, June, July and August.

So WWIL got set for another Turtle Watch. The full moon was to appear shortly after 4 this morning (Aug. 5), and the 250-pound to 2,000-pound mama sea turtles were due on beach shortly thereafter.

The station has offered prizes for participants and also words of caution. Among them: Do not walk on the beach with sparklers or flashlights and don't make any quick movement or loud noise or the turtles will return to the ocean. A further admonition cautioned watchers against putting their hands in front of the turtle's mouth, "as she will bite it off."

The contest is being run in cooperation with the Florida Fish and Game Commission, which is guardian of the eggs once they are laid.

Drumbeats . . .

First award ■ A certificate of commendation has been presented by the California attorney general to KRON-TV San Francisco, in recognition of *Junkie*, a two-part documentary on drug addiction. The attorney general said the award, the first made by his

office to any media, will be presented in the future for outstanding coverage of significant events and subjects.

Sugar 'n' spice ■ An illustrated cookbook, designed for 6 to 12-year-old girls, is being offered by the Imperial Sugar Co. on 30 Texas television stations this summer. The spots, offering "My First Cookbook," feature demonstrations by little girls.

Herculean task ■ It took 24 days and 903 station breaks, but WHPB Belton, S. C., has saluted every radio station in the United States, Puerto Rico and the Virgin Islands. Using the BROADCASTING YEARBOOK as its source, the station sent salutes to 3,609 stations as a reminder to its listeners that "wherever you go, there's radio."

Network guide ■ Avery-Knodel Inc., radio and TV station representatives, has prepared and distributed a 1963-64 TV network guide chart to 1,400 agency and advertiser personnel. The guide contains program information, starting date, sponsors and whether the shows are new, old ones in new time slots or shows continuing in last season's spot.

Bouncing eye introduces new call letters

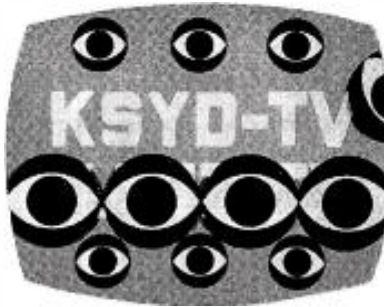
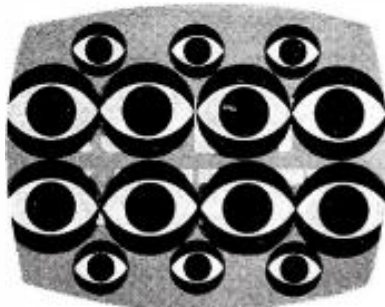

KSYD-TV Wichita Falls, Tex., has changed its call letters to KAUZ-TV. To promote the change an extensive animated on-air promotion was produced and ran for three days before the changeover became effective. The animation included both sets of call letters with the CBS Eye

bouncing around.

The channel 6 CBS affiliate took new call letters as part of the change in ownership from Sidney A. Grayson and Associates to Paul Harron and group (BROADCASTING, March 18).

More than 3,000 entries from

agency and advertiser personnel were received in the KSYD-TV contest to get new call letters. H. Wendell Eastling, media director, Knox-Reeves Advertising, Minneapolis, won first prize of an MG sports car and a trip for two to Wichita Falls for selecting KAUZ-TV.



A revised guide will be published in January.

Folksy baseball ■ KDKA Pittsburgh and the Pittsburgh Pirates have concluded a series of three "Teen-age Nights" at Forbes Field. On the special nights, teen-agers were admitted for 50 cents and saw a hootenanny in addition to a baseball game.

Big push ■ A 12-month statewide radio-television tourist promotion is being undertaken by the 165 members of the Georgia Association of Broadcasters. The agreement between the GAB and the state's Department of Industry and Trade calls for 20,000 announcements, programs and special events promoting tourism in Georgia.

Pay the bills ■ WEJL Scranton, Pa., and its parent company, the *Scranton Times*, are sponsoring the entertainment at the local United Fund drive kickoff. Featured will be Vincent Lopez and his orchestra.

Publicists play ball ■ NBC publicity men gave the "scoop" away to ABC press information boys losing a "tightly" played softball game to their ABC counterparts, 5-2. ABC reported they never received a serious challenge that both NBC runs resulted from errors. NBC reported that all ABC runs were unearned. Another game is scheduled between the two teams Aug. 26.

Boston hoot ■ A hootenanny, held for the "Jimmy Fund" Children's Hospital for Cancer Research by WBZ Boston, drew more than 30,000. Held on the banks of the Charles River, the show was recorded and broadcast the following day by the Westinghouse station.

'Instant Weather' ■ KABC Los Angeles is using billboards, a two-month saturation newspaper campaign and TV spot announcements to publicize its new "Instant Weather" telephone service. The station has installed its own weather information equipment and put in 40 telephone lines and two telephone recorders to accommodate callers.

Prizes for pride ■ WJZ-TV Baltimore is offering 101 prizes worth more than \$10,000 for letters from Baltimoreans expressing pride in their city. Winning letters will be displayed at the Maryland exhibit in the 1964 New York World's Fair.

Voice of year ■ George Walsh, announcer at KNX Los Angeles, named the "1963 Voice of California," is overall winner of a statewide competition held each year by the California State Fair and Exposition. Mr. Walsh will announce the opening of the 1963 state fair in Sacramento on Aug. 28.

July 4th special ■ WBRC-TV Birmingham, Ala., televised four special pro-



Ah-h-h-h, now that wasn't so hard

Peter M. Affe, station manager, WNBC-TV New York, really doesn't cut out paper dolls. But he does look at them. Mr. Affe is inspecting one of more than 12,000 entries submitted by children from 3 to 7 years old in the station's "Happy,

Happy Birthday" card drawing contest. It was held over a four-week period by WNBC-TV's *Birthday House* children's show (Mon.-Fri., 9-9:30 a.m.). The cards will be displayed in the Chase-Manhattan Bank in midtown New York.

grams July 2-4, as part of the station's 10th annual "Flag Raising Ceremony." The event, which has won a Freedoms Foundation award for the past three years, honored the Air Force this year.

Wither thou goest ■ Wsb Atlanta is offering a weekend holiday to listeners, but the vacation location won't be announced until the contest ends Aug. 15.

Hot and cold ■ With the July temperature in the 90's, WEBB Baltimore conducted its second annual snowball jamboree for more than 3,000 children.

Two tons of snow "imported" from an ice company was used and 120 children received prizes for being the best snowball throwers.

Promotion plans ■ WOR-TV New York is planning to promote the *Funny Company* with a nearly \$1 million all-media campaign. The syndicated program, which will be telecast for 90 minutes Monday-Friday beginning this fall, will be backed by a campaign using radio-TV, magazines, newspapers, theater promotion and transit ads.

Good guess ■ A 100-year-old Mexican century plant bloomed in St. Paul and was worth \$100 to the listener who correctly guessed the number of blooms, 732. The contest was run by WCCO-TV Minneapolis.

Good guess and gesture

KNEZ Lompoc, Calif., asked listeners to guess the number of flowers painted on the KNEZ flower car in the Lompoc Flower Festival and offered the car as the prize. The winner was Dale Owens, program director of KKOK Lompoc, KNEZ's new rival, who entered a guess of 1410 flowers (KKOK's frequency is 1410 kc) on behalf of the station. When it was announced that KKOK had won, the station relinquished the prize to the next closest guess to the actual number of painted flowers—1,409.

Quite a news staff

The *Esso Reporter* newscast which has begun on KTAL-TV Shreveport, La., has given the station an opportunity to acquire hundreds of extra reporters for its news staff.

In a campaign "to make the Esso people feel they are a part of the station," KTAL-TV gave cards to each Esso station attendant, making him an "Honorary Esso Reporter." A sticker was placed by the telephone at all Esso service stations giving the telephone number of the KTAL-TV newsroom. The

station is paying stringer fees for stories called in by the "honorary" reporters.

Broadcasters support Detroit Olympic drive

Michigan radio and TV stations have blanketed the state with public service announcements in a drive to obtain the 1968 Olympic Games for Detroit.

The campaign was intended to raise \$400,000 in public contributions to finance Detroit's bid for the Olympics. The Michigan Association of Broadcasters sponsored the drive on 120 radio and 16 TV stations. Spot announcements, with a background of a fife and drum corps, carried the theme "The

Spirit of '68."

Harry Lipson, vice president-general manager of WJBK-AM-FM Detroit, served as chairman of the broadcast drive. Competing with Detroit for the Olympics are Lyon, France; Mexico City, and Buenos Aires. The presentations will be made before the International Olympic Committee, meeting in Nairobi, Kenya, in October.

Subteen market courted with Delta's stamp plan

There are postage stamps, tax stamps, savings stamps and trading stamps. Now Delta Airlines, Atlanta, has plans to offer travel stamps in its radio-TV commercials.

Delta hopes the stamps, which cost

\$1 each, will be an inducement for the subteen market—aged 10 to 12—to save a book of 150 stamps and trade the book in for a package tour of the New York World's Fair, which opens next April. The stamp-filled books can be exchanged for regular Delta tickets also.

With an all-media promotion campaign targeted initially for Atlanta, New Orleans and Houston, Delta's ad manager, George E. Bounds, said the airline is "breaking new ground . . . preselling air travel to an oncoming generation of potential customers."

The stamps are now sold through Delta offices and will be available at banks and travel agents.

Delta's agency is Burke Dowling Adams, Atlanta.

FATES & FORTUNES

BROADCAST ADVERTISING



Mr. Upson

Stuart B. Upson, account supervisor at Dancer - Fitzgerald - Sample, New York, elected senior vice president. Mr. Upson joined DFS 17 years ago and was elected VP in 1954.

Richard B. Kreuzer, assistant VP of Albert Frank-Guenther Law, San Francisco, elected vice president. Mr. Kreuzer has been with agency for past 12 years.

Warren Bryan, TV production supervisor at Sullivan, Stauffer, Colwell & Bayles, New York, elected VP.

George C. Whipple Jr., director of public relations for Benton & Bowles, New York, named to additional post of general manager of General Public Relations, a B&B division.

Richard Bull named national advertising manager of Nationwide Insurance Cos., Columbus, Ohio, effective Sept. 1. Mr. Bull joined company in 1951 and has served as assistant to Nationwide President Murray Lincoln since 1957.

James Norton, member of Los Angeles office of McCann-Erickson, joins Television Bureau of Advertising, that city, effective today (Aug. 5).

William L. Lemons, account executive in Los Angeles office of Grant Adv., joins Grey Adv., that city, in similar capacity.

Jane T. Darden named media director of Hal Stebbins Inc., Los Angeles advertising and PR firm. Miss Darden joined Stebbins in 1961.

William E. Jasinski, associate media director since 1961 at Kircher, Helton

& Collett, Dayton and Cincinnati advertising agency, named media director.

Richard E. Carls, formerly of Procter & Gamble, joins Street & Finney Inc., New York, as assistant account executive on Colgate-Palmolive account.

Ace Diamond, producer of *Story-Line* on KNX-AM-FM Los Angeles and CBS Radio network's *In Hollywood* show, joins Hal Phillips and Associates, Los Angeles, as account executive.

James Alexander, assistant media director at Lennen & Newell, New York, joins Fletcher Richards, Calkins & Holden, that city, as media group supervisor with primary responsibilities on Eastern Airlines account.

William Caro, former production manager at Dancer-Fitzgerald-Sample, San Francisco, joins Fuller & Smith & Ross, Los Angeles, as media buyer.



Mr. Harris

Donald S. Harris, director of media for Philip Morris Inc., New York, promoted to media and programming director. **Clifford R. Wilmot Jr.** appointed assistant Marlboro brand manager, and **Vincent J. Weiner** to production supervisor. Mr. Harris joined Philip Morris in 1961 in his present capacity. From 1960 to 1961 he was VP-director of media for Fitzgerald Adv. in New Orleans, moving there from Benton and Bowles where he was VP and media director.

Nancy Fritz, market research assistant at MacManus, John & Adams, elected president of Los Angeles Junior Advertising Club for 1963-64. Other officers are **Al Shonk**, Keith Evans & Associates, first VP; **Kent Valandra**, Bank of America, second VP; **Mary**

Ann Nordstrom, *Herald Examiner*, recording secretary; **Penny Page**, Bullock's, corresponding secretary; **Robin Jarecki**, Munger & Marshall, treasurer.



Mr. Fagan

Frank Fagan, executive VP of Young & Rubicam, New York, retired last week after 29 years with agency. Mr. Fagan joined Y&R in 1934 in merchandising department. He was appointed to agency's contact department in 1938, elected VP in 1943, appointed to executive committee and plans board in 1946, and elected senior VP in 1953 and executive VP in 1958. Several years ago Mr. Fagan, in preparation for his retirement, purchased small marine supply business at Greenport, L. I., N. Y.

Robert E. Gips, radio-TV production director at Doyle Dane Bernbach, Los Angeles, joins Guild, Bascom & Bonfigli, that city, as TV producer. Previously, Mr. Gips was VP in charge of production for Mel Gold Productions and supervisor and director of film commercials for National Screen Service Corp., both New York.

Mary Meahan, senior media buyer at Fuller & Smith & Ross, joins Kudner Agency, New York, as media buyer.

Merl Bloom, formerly with Reach, McClinton & Co., joins Lawrence C. Gumbinner Adv. as radio-TV producer.

Earl J. Obermeyer, former account executive at Rich Adv., Buffalo, N. Y., joins The Rumrill Co., advertising, PR and marketing agency, Rochester, N.Y., as marketing executive.

Lionel C. Barrow Jr., formerly with Bureau of Advertising of American Newspaper Publishers Association, joins

Kenyon & Eckhardt, New York, as research project supervisor. **Paul Roth** appointed assistant research director for media and economic research of Kenyon & Eckhardt. Mr. Roth had been media group head at agency.

Albert C. Book resigns as copy chief in charge of commercial content for *DuPont Show of the Week* at BBDO, New York, to accept associate professorship post at University of Nebraska School of Journalism, effective Aug. 15. Mr. Book joined BBDO in his present capacity in 1955. Prior to his assignment to *DuPont Show*, he worked on content of *General Electric Theater*.

Mary Quirk, William R. Stratton and Thomas J. Shutter, TV copywriters at Leo Burnett Co., Chicago, promoted to copy supervisors. Miss Quirk has been with agency 10 years; Mr. Stratton joined in 1958, and Mr. Shutter, formerly with WBKB(TV) Chicago, joined Burnett in 1961.

William J. Jacobs, formerly with WGR and WKBW, both Buffalo, N. Y., and MacManus, John & Adams, joins D. P. Brother & Co., Detroit, as radio-TV writer. **Richard P. Shesgreen**, formerly head of his own advertising agency in Detroit, joins Brother as copywriter on Oldsmobile account.

Edward F. Murphy elected assistant controller of Kenyon & Eckhardt Inc., New York. Mr. Murphy has been with agency since 1956.

Eugene R. Hatton, account executive at Gardner Adv., St. Louis, joins Earle Ludgin Co., Chicago, in same capacity.

Eileen Brennan, former product manager at Coty Inc., joins Cunningham & Walsh, New York, as account executive. **Arthur Hofman**, account executive at Lennen & Newell, and **Richard Tousey**, account executive at Dancer-Fitzgerald-Sample, join C&W in similar capacities.

Benjamin Colarossi joins Ted Bates & Co. as production supervisor. Mr. Colarossi was formerly TV producer and art director at Kenyon & Eckhardt.

Robin Page joins Tatham-Laird, Chicago, as account executive. Mr. Page formerly was with J. Walter Thompson Co. and head of his own advertising agency in New Jersey.

James O. Bridges and **Russell D. Bowman**, both formerly of BBDO, New York, join Ketchum, MacLeod & Grove, that city, as account executive

and assistant account executive, respectively. **Michel Will**, *Redbook* magazine art editor, joins KMG as art director.

King W. Bridges Jr., manager of Waco, Tex., office of Southwest Adv. Agency, joins Rives, Dyke & Co., Houston, as account executive.

Frank T. Nolan, research analyst at Kudner Agency, New York, named to newly created post of group research supervisor, directing work of research analysts and statisticians on special projects. **Kenneth Dudwick** and **Irwin Sarason** join Kudner as art directors. Mr. Dudwick was formerly with Campbell-Ewald and Grey Adv. Mr. Sarason was with CBS-TV, New York.

W. B. Hackenberg, general promotion manager of Campbell Soup Co., named chairman of sales promotion committee of Association of National Advertisers. Mr. Hackenberg succeeds **Daniel C. Brown**, vice president in charge of advertising and sales promotion for Baumritter Corp.

Paul T. Hughes, in sales and promotion at Western Airlines, joins Sudler Adv., Los Angeles, as account executive.

THE MEDIA



Mr. Lipton



Mr. Raymon

Paul Raymon, local sales manager of WAGA-TV Atlanta, promoted to general sales manager, effective Aug. 15, replacing **Buzz Hassett**, who resigns to become assistant general manager of WGHP-TV Greensboro-High Point, N. C. **Charles J. Lipton**, WAGA-TV account executive, will become local sales manager. Mr. Raymon, former announcer-sports caster for CBS Radio network

and sports director with Storer organization, was appointed to his present post in 1960. Mr. Lipton joined WAGA-TV staff in December 1962 from post of vice president and local sales manager for WTOG-TV Savannah, Ga.

Dan E. Bellus, director of advertising and promotion for Transcontinent Television Corp., New York, appointed station manager of WDOX-AM-FM Cleveland. Previously he served as director of sales development and promotion for KFMB-AM-FM-TV San Diego and as general sales manager of KFMB radio. Before joining Transcontinent, Mr. Bellus was sales manager of KFEQ-TV St. Joseph, Mo., sales manager and assistant station manager of KRVN Lexington, Ky., and general manager of KNEX McPherson, Kan. Transcontinent Stations are WGR-AM-FM-TV Buffalo, N. Y.; KFMB-AM-FM-TV San Diego; KERO-TV Bakersfield, Calif.; WNEP-TV Scranton-Wilkes-Barre; WDAF-AM-FM-TV Kansas City; and WDOX-AM-FM Cleveland.



Mr. Bellus

J. Alvin Jeweler appointed general manager of WHFS-FM Bethesda, Md. High-Fidelity Broadcasters Inc., operators of WHFS-FM (102.3 mc), has been purchased by Dixon Industries Inc., Gaithersburg, Md.

Fred G. Goddard, VP and general manager of KXRO Aberdeen, Wash., announced his retirement, effective Sept. 1. Mr. Goddard began his broadcast career in 1929 at KVOS Bellingham, Wash. He moved to KXRO in 1931.

Don L. Pierce appointed manager of WNBE-TV New Bern, N. C. Station has scheduled target date of Sept. 1.

William Dutcher, production manager of WMT-TV Cedar Rapids, Iowa, appointed station manager of WMT-FM, effective today (Aug. 5). Mr. Dutcher succeeds **Daniel Katz**, who leaves post in September to join The Katz Agency

**RADIO STATION
FORCED SALE!**

See page 79

Hamilton-Landis
& ASSOCIATES, INC.

United Press International
Facsimile Newspictures and
United Press Movietone Newsfilm
Build Ratings



in New York. Frank Miller appointed WMT-TV production manager.

Ken Berryhill resigns as manager of WNAG Grenada, Miss., to become director of public relations for Southwestern College in Memphis, Tenn.

George E. Dail, VP in charge of sales for WCMS Norfolk, Va., appointed general manager of WTD Newport News-Norfolk and elected president of Twelve-Seventy Inc., licensee of station.



Mr. Shireman

R. E. (Dick) Shireman elected vice president of Star Stations (KOIL Omaha, KISN Portland, Ore., and WISH Indianapolis, sale of WISH subject to FCC approval). He will continue in his capacity as director of sales. Mr. Shireman has been associated with Star Stations for past four years, including service as manager of KISN Portland. Prior to that time he was associated with Hearst organization in Milwaukee.

Eve Rubenstein named sales manager of KQTV(TV) Fort Dodge, Iowa.

Robert Howard named manager of national sales for WNBC-TV New York. Mr. Howard, who joined NBC 15 years ago, held posts in research and sales development for NBC-TV and was sales representative for NBC Radio and TV Spot Sales. He replaces **Jay J. Heitin**, who resigned to join teaching staff of Santa Barbara College.

Robert J. Warner, assistant sales research manager for KNXT(TV) Los Angeles, promoted to account executive.

Dennis Holt, with RKO General sales in San Francisco, transfers to RKO General-owned KHJ-TV Los Angeles as account executive.

Donald W. Cuthrell Jr. named account executive at WTAR-AM-FM Norfolk-Newport News, Va.

Monte Lang, former account executive at McGavren-Guild Co., joins Blair Radio, New York, in similar capacity. **John Leroy Welford**, formerly with National Shawmut Bank of Boston, joins Blair's Boston office.

Bill Trotter appointed sales manager of KALO Little Rock, Ark.

Dorothy Allen, formerly of KTLA(TV) Los Angeles, joins KHJ-TV, that city, as research director.

Lawrence E. Brown and **Dewey J. Parr Jr.** join TV and radio sales staffs respectively of WSAZ-AM-TV Huntington, W. Va. Mr. Brown is former district sales manager for Time-Life Inc. Mr. Parr is former salesman for Mutual and United of Omaha.

Joseph O'Connor joins sales depart-

ment of WLBW-TV Miami.

David L. Reeves, sales representative for *Philadelphia Inquirer*, joins sales department of WIP-AM-FM Philadelphia as account executive.

Morrie Taylor and **Al Kenyon** join sales department of KMEQ and KQAL-FM, both Omaha, Neb.

John Katz, member of radio sales staff of The Katz Agency in Dallas, transfers to station representative's radio sales staff in St. Louis.

William W. Greer of Petersburg, Va., appointed executive secretary of Virginia Association of Broadcasters, succeeding **E. J. (Hugh) DeSamper** of Williamsburg. Mr. DeSamper resigned last month because of increased responsibilities involved in his promotion to post of director of press bureau of Colonial Williamsburg. According to VAB President **Horace Fitzpatrick**, WLS-AM-FM-TV Roanoke, association headquarters is being shifted to Petersburg.

Herb James joins staff of WMT Cedar Rapids, Iowa, as account executive.



Mr. Krauss

Mitchell Krauss, director of news and programming for WRUL (Scituate, Mass.) New York, international commercial shortwave station operated by Radio New York Worldwide, elected vice president for operations. Before joining Worldwide Mr. Krauss was director of news at WIP-AM-FM Philadelphia, and has also been associated with WQXR-AM-FM New York, WFLN-AM-FM Philadelphia and former WGYN New York.

Paul Sonkin named director of research for ABC-TV network. **Seymour Amlen**, manager of program analysis and marketing, becomes associate director of research. **John Tiedemann**, supervisor of audience measurements, succeeds Mr. Sonkin as manager of audience measurements, and **Sheldon Jacobs**, senior research analyst, succeeds Mr. Tiedemann. Research department will continue to report to **Fred Pierce**, director of planning and sales development, ABC-TV network.

William Diehl, director of news and special events for WTKO Ithaca, N. Y., assumes duties as operations director of WTKO and Northeast Radio Network.

Rick Blakely, former manager of KWAY Forest Grove, Ore., joins KFHA Tacoma, Wash., as program director.

Larry M. Harding, formerly of WBT-AM-FM Charlotte, N. C., named promotion manager of WBT(TV), that city. **Joseph Young**, assistant to director of public affairs, promoted to WBT promo-

tion manager. **Joseph H. Dawson**, on-the-air writer for WBT(TV), named sales presentation writer for WBT(TV) and WBT(TV) Florence, S. C. Stations are owned by Jefferson Standard Broadcasting Co.

Martin Gray, program director and air personality at WIBW Topeka, Kan., joins staff of WDAF Kansas City, Mo.

Patrick C. Arnoux, former program director at WSPA-TV Spartanburg, S. C., appointed general program manager of WNBE New Bern, N. C.



Mr. Meagle

Howard W. Meagle, recently appointed assistant general manager of WWVA-AM-FM Wheeling, W. Va. (BROADCASTING, July 22), promoted to general manager, effective Aug. 16, replacing **Paul J. Miller**, who announced his resignation last week (BROADCASTING, July 29). Mr. Meagle formerly served as WWVA's general sales manager.

Scott Runge, producer at Video Tape Enterprises, Los Angeles, joins KNX-AM-FM, that city, as producer on *Story Line* program.

Les Crane, formerly of KGO-TV San Francisco, joins WABC-TV New York, effective Sept. 15, as host of *Night Line with Les Crane*. Both stations are owned by ABC.

Robert Irwin, formerly of WCYF-FM Cleveland, joins programing department of WJW-TV, that city.

Alvin Perlmutter, former program manager of WNBC-TV New York, joins National Educational Television as executive producer of half-hour weekly news background series which will begin on 72-station network Oct. 7. Mr. Perlmutter also continues as vice president of Spectrum Associates Inc., a television packaging firm.



Mr. Baudino

Joseph E. Baudino, VP of Westinghouse Broadcasting Co., Washington, appointed chairman of National Association of Broadcasters' 1963-64 by-laws committee. Other committee members are **John R. Henzel**, WHDL Olean, N. Y.; **Ray Johnson**, KMED Medford, Ore.; **Robert T. Mason**, WMRN Marion, Ohio; and **James D. Russell**, KKT(TV) Colorado Springs, Colo.

Joseph C. Monroe and **Barnard B. Wilson** join local radio and television sales staffs, respectively, of WFAA-AM-FM-TV Dallas-Ft. Worth. Mr. Monroe is former part owner and manager of

KJOE and KBCL, both Shreveport, La. Mr. Wilson formerly served on local sales staff of KONO-TV San Antonio. **Terrence S. Ford**, former assistant promotion manager of WJW-TV Cleveland, appointed to WFAA's radio promotion department. Item was incorrectly reported in July 22 issue of BROADCASTING. **George Utley** remains manager of WFAA-AM-FM.

David Allan, formerly host of *Club 27* show at WKBN-TV Youngstown, Ohio, joins WNBC-TV Boston as host of *David Allan Show*, beginning Sept. 9 (9:30-9:55 a.m.).

Joe Constantino, promotion manager of KTVU(TV) Oakland-San Francisco, elected president of San Francisco chapter of Sales Promotion Executives Association. Other officers elected are **Jack Shelton**, direct mail consultant, first VP; **Dick Robertson**, KRON-TV San Francisco, secretary; and **Evelyn Clark**, Pacific Programs & Promotions, treasurer.

Wally Olson, station manager of WLOI La Porte, Ind., for past two years, promoted to general manager.



Mr. Olson

Jim King joins WQAD-TV Moline, Ill., as sports director. Station was scheduled to begin operating Aug. 1. Mr. King was previously in sports department at KETV(TV) Omaha, Neb.

John Hokom, national sales representative for KNX-AM-FM Los Angeles, appointed director of information services for KNX radio and CBS Radio Pacific Network. Mr. Hokom succeeds **Arthur Wittum**, who resigned.

William A. Brendle, with ABC-TV network press department since 1953, in charge of sports publicity, joins CBS-TV network press information department as sports manager.

Sheldon Shemer, producer-director at WJZ-TV Baltimore, appointed director of sports programming.

Gene Walsh appointed manager of business and trade publicity for NBC press department, succeeding **Alan Baker**, recently named program publicity director. Mr. Walsh, who has been assistant trade news editor since January 1962, joined NBC press department in January of previous year. **Richard J. Connelly**, staff writer with

news unit of NBC press, succeeds Mr. Walsh as assistant trade news editor. Mr. Connelly joined NBC in July 1961.

J. Richard Turner, former station manager of WINF Hartford, Conn., joins RKO General's Yankee division as assistant manager for merchandising and sales coordination.

Jack Sameth named executive producer for ABC-TV programing department, succeeding **John B. Green**, who resigned to become producer of *100 Grand*, new quiz show to debut on ABC-TV this fall. Mr. Sameth had been an ABC-TV director since 1955.



Mr. Sameth

Michael Hardgrove, assistant director at WTOP-TV Washington, promoted to director, replacing **Hall Jones**, who resigned. **Laird C. Simons Jr.** named assistant TV director.

Billie McNeilly, radio homemaker, returns to KMA Shenandoah, Iowa, with her daily half-hour program, *It's A Woman's World* (Monday-Saturday, 10:30 a.m.).

Cal Hackett, former air personality at WOOK Washington, and **Marion Harper**, of publicity departments of WJZ-TV Baltimore and Baltimore Colts football team, join WWDC-AM-FM Washington, respectively, as music librarian and producer of *Steve Allison Show*.

Philip G. Rebert, previously with Al Paul Lefton Co., Philadelphia advertising agency, appointed film director of WHYY-TV Wilmington, Del.

Loring D'Usseau, producer-director of Facilities Rental division of Paramount Television Productions, Los Angeles, named executive producer at KTLA(TV), that city, and Paramount TV Productions. In new capacity Mr. D'Usseau will serve as administrative assistant to S. L. Adler, station's general manager, and Robert Quinlan, assistant general manager and program director.



Mr. D'Usseau

Pete Berry, air personality at WABY Albany, N. Y., assumes added duties as music director. **Lee Gray** named WABY's promotion-production director.

Raymond J. Cheney, sales manager of WNBK Binghamton, N. Y., promoted to newly created post of station manager for AM outlet. Item published in July 29 issue of BROADCASTING erroneously stated that Mr. Cheney had been sales manager of both AM and FM facilities and that he was promoted to

station manager of both AM and FM operations. WNBK-FM is a separate operation with Warren Koerbel as station manager and William Wahl as sales manager.

Harvey Firestone, formerly of Ralph Bing Adv., joins promotion department of WJW-TV Cleveland.

Paul W. Morency, president of Travelers Broadcasting Service Corp. (WTIC-AM-FM-TV Hartford), appointed by Governor John N. Dempsey to Connecticut Commission on Arts.

John Smith, former newsman with WADO New York, appointed staff announcer of WWRL, that city. Mr. Smith is on staff of U. S. Information Service.

PROGRAMING

John Freese, former Young & Rubicam vice president in charge of commercial productions, joins VPI of California. Mr. Freese will make his headquarters in San Francisco and be in charge of all phases of production for TV commercial production company.

Les Brown, bandleader, elected president of Los Angeles chapter of National Academy of Recording Arts and Sciences. Other officers for 1963-64 are first VP, **John Scott Trotter**; second VP, **Jo Stafford**; secretary, **Hugh**



CONTINENTAL'S TYPE MR1C MONITOR RECEIVER

- Monitors transmitter operation at studio location
- Indicates relative field intensity at pickup point
- Has audio monitoring channel
- Gives warning lamp for carrier, buzzer alarm for loss of carrier

write for details today

*Continental
Electronics*

PRODUCTS COMPANY
BOX 5024 • DALLAS 22, TEXAS • TELEX CEPCO
LTV Subsidiary of Ling-Temco-Vought, Inc.

RADIO STATION FORCED SALE!

See page 79

Hamilton-Landis
& ASSOCIATES, INC.

Davies; treasurer, **Al Schmitt**.

Ed Montagne, producer of *McHale's Navy* (Thursdays, 9:30-10 p.m., ABC-TV) for Revue Studios, Universal City, Calif., elected VP.

Bert Granet, executive producer of *Twilight Zone* TV series, named producer of CBS-TV's forthcoming series, *The Great Adventure*, replacing **John Houseman**, who has resigned post (BROADCASTING, July 29). Mr. Houseman will, however, complete first six segments of *Adventure* before leaving.

Del Porter, formerly of Anderson-McConnell Adv., Los Angeles, joins Ad Staff Inc., Hollywood, as principal of the commercial production company. Ad Staff has moved to new offices at 1680 North Vine Street.

Howard Grafman, former general manager of WXFM(FM) Elmwood Park, Ill., appointed central division sales manager of Allied Artists Television Corp., with headquarters in Chicago.

Albert McCleery, former producer with CBS-TV in New York, joins Selmur Productions Inc., ABC-TV wholly owned production subsidiary in Hollywood, as producer-director for both live and film shows. First assignment is to produce one-hour pilot of *Alexander the Great*, color costume drama, for 1964-65 season, now being written by Robert Pirosh.

Art Greenfield appointed national sales manager of M&A Alexander, Hollywood syndicator of films for TV.

Stanley Niss, producer of *Arrest and Trial* series for Revue Studios and formerly with Warner Brothers and CBS, joins MGM-TV to produce initial segment, "Seven Rich Years . . . And Seven Lean," of new full-hour dramatic series, *Great Stories from The Bible*, scheduled for 1964-65 season on ABC-TV network.

Hsin Ch'en, film editor, joins Sarra Inc., New York television commercial producer.

Howard Browne appointed producer of new hour-long ABC-TV outdoor adventure series, *Destry*, to be produced by Revue Studios. Series, scheduled to get underway in mid-August, will be based partly on classical Universal motion picture, "Destry Rides Again," starring James Stewart and Marlene Dietrich. **John Gavin** has been set for title role.

Ken Kragen and **Tom Carroll**, concert producers associated with Limeriters and other groups, form Kragen-Carroll Inc. to operate in personal management, concert production and public relations. New firm is located at 451 North Canon Drive, Beverly Hills, Calif. Telephone: 273-5011. Before entering concert production, Mr. Car-

AWRT elects trustees

Twelve new trustees have been elected to board of American Women in Radio and Television Educational Foundation.

New trustees are **Dorothy Buhr**, J. Walter Thompson, San Francisco; **Dora Cosse**, Dora-Clayton Station Representatives, Atlanta; **Florence Cyhel**, Potts-Woodbury Adv., Kansas City, Mo.; **Mary E. Harris**, M-E Productions, McCann-Erickson, New York; **Mimi Hoffmeir**, NBC, New York; **Leontine Keane**, WTVS(TV) and WDET Detroit.

Clair McCollough, Steinman Stations, Lancaster, Pa.; **Angela McDermott**, Heath de Rochemont, Boston; **Leonard Reinsch**, WSB-AM-TV Atlanta; **Mary Roebing**, Trenton Trust Co., Trenton, N. J.; **Irene Runnels**, KBOX Dallas; **Theodora Zavin**, Broad-Music Inc., New York.

roll had been music director and assistant program director of WBZ Boston. **Ted Pettit**, formerly in charge of press information for KNX Los Angeles, is handling PR and publicity aspects of Kragen-Carroll operation.

Winston O'Keefe appointed producer of *Grindl*, new NBC-TV series starting Sunday, Sept. 15. Mr. O'Keefe has served as producer for Screen Gems and producer in charge of talent for former *NBC Matinee Theater*.

John F. Gault, for past seven years with Teleprompter Corp., joins Television Communications Corp. (formerly Televents Corp.), Denver, as New England regional manager.

Dan Fitzgerald, formerly of Calvin Productions, Kansas City, joins Animation Inc., Hollywood producer of animated films.

Herbert Sargent and **Bob Fletcher** signed as chief writer and scenic-costume designer, respectively, for seven special color broadcasts of *Perry Como's Kraft Music Hall* to be presented various Thursdays (10-11 p.m. EDT) on NBC-TV next season.

Nelson Riddle signed by Screen Gems to write musical arrangements and background for company's new *Redigo* TV series.

Diana B. Wenman named office administrator for Sandy Howard Productions, Hollywood TV production firm.

Irving Gertz, composer-musical producer who formerly worked with 20th Century-Fox, signed by Jack Douglas to compose and score theme music for new, nonfiction TV series, *America*,

now in production. Mr. Gertz, who composed musical scores for *Adventures In Paradise* TV series, also scored two other Douglas TV series, *Across the Seven Seas* and *The Golden Voyage*.

Allan House Jr., former producer with Sutherland Associates, joins Sarra Inc., New York commercial production firm, as sales production executive.

Jules Seidman named to newly created post of editorial and mixing supervisor for MGM Telestudios, New York. Mr. Seidman has served as director and associate director of such TV musical programs as *Astaire Time*, *The Andy Williams Show*, *The Victor Borge Show*, and *The George Burns Show*.

Arthur Barron, with accounting firm of Lybrand, Ross Brothers & Montgomery, Los Angeles, named assistant controller at Desilu Productions.

David Butler re-elected chairman of Directors Guild of America educational and benevolent foundation. Also re-elected for one year terms were **Willis Goldbeck**, first VP; **Leo McCarey**, second VP; **John Rich**, secretary; and **Leslie Selander**, treasurer.

Egbert W. Swackhamer signed to multiple directing contract on Desilu's new *Glynis* series which begins this fall on CBS-TV. Series is produced by Ed Feldman and stars Glynis Johns, Keith Andes and George Mathews.

Paul Mason, who recently completed several teleplays for *The Greatest Show On Earth* TV series, signed by Revue Studios, Universal City, Calif., as script consultant on *Arrest and Trial*, new 90-minute ABC-TV dramatic entry.

Ron Roth, former assistant to Dick Berg, producer, elevated to associate producer by Revue, for current filming of NBC-TV *Bob Hope Chrysler Theatre* series, to premiere Oct. 4.

NEWS



Mr. Majeski



Mr. McCarty

Charles J. McCarty appointed assistant general manager of United Press International Newspictures, New York, succeeding **Harry Varian**, who recently took charge of UPI's television news operations. **Edward T. Majeski** named to new position of Newspictures managing editor. He will supervise both spot and feature picture coverage under **Harold Blumenfeld**, executive editor of photo service. Mr. McCarty joined Acme Newspictures, predecessor of UPI Newspictures, in 1947 in San

Francisco. He was southwest division Newspictures manager at Dallas until moving to New York last year as picture news editor. Mr. Majeski joined Acme in New York in 1941. He has served as New York picture bureau manager, telephoto editor and picture news editor.

Mike Chamberlain, news editor of wsJV(TV) South Bend-Elkhart, Ind., and WTRC-AM-FM Elkhart, promoted to assistant news director.

Paul Taylor, formerly of WRCV-TV Philadelphia, joins WHYV-TV Wilmington, Del., to handle news assignments.

Al Benedict joins news department of WTRF-TV Wheeling, W. Va., as reporter, writer and newscaster.

Ben Chandler, formerly of KMPC Los Angeles, and **Ted Meadows**, of KEWB San Francisco, join news staff of KLAC-AM-FM Los Angeles.

Robert Chandler, for past two years director of TV publicity for MGM-Television, joins CBS News, New York, effective Aug. 12, as director of information and special services. Before joining MGM-TV, Mr.



Mr. Chandler

Chandler was with *Variety* for nine years, covering TV and radio in publication's Chicago, New York and Hollywood offices. In new post he will assist Richard S. Salant, CBS News president, and Blair Clark, CBS News VP and general manager, in formulation of division policies and have responsibility of maintaining liaison with CBS press information departments.

Arthur Curley, former newscaster and air personality at WDEL Wilmington, Del., joins announcing staff of WBAL-AM-FM-TV Baltimore.

William A. Earman, operations manager of WPDQ Jacksonville, elected president of Florida AP Broadcasters Association, succeeding **Vernon Lundquist**, WINK Ft. Myers.

INTERNATIONAL

Dick Sheppard named FM sales supervisor for Stephens & Towndrow Ltd., Toronto station representative.

F. Cameron James and **William F. Burden**, both account supervisors at MacLaren Adv. Co. Ltd., Toronto, elected VP's. Mr. James joined agency

in PR department in 1950 and was promoted to account supervisor in 1959. Mr. Burden originally joined MacLaren in 1935. He was named account executive in 1952, and supervisor in 1961.

Tom Tonner, general manager of CHSJ Saint John, N. B., appointed station manager of CFMB Montreal.

J. Bruce Swigert, former VP of Foreign Adv. and Service Bureau in New York, appointed U. S. manager of international division of Gardner Adv. Mr. Swigert, who will be based in agency's St. Louis office, will report to John H. Leach, VP and director of Gardner's international division, and be responsible for coordinating advertising activities for agency's clients in Latin America and Pacific area. His previous experience includes posts with McAdams International and with McCann-Erickson in South America and Caribbean.



Mr. Swigert

Edward Mutimer, CBWT(TV) Winnipeg, Man.; and **Frank Ord** and **Arthur Warwick**, both of CBOT(TV) Ottawa, Ont., have been loaned for 12-18 months to government of Malaya to assist in establishing television in that newly independent British Common-

wealth country. **G. F. Brickenden**, formerly Canadian Broadcasting Corp. regional director for Atlantic Coast provinces, has been TV advisor to Malayan government since last January.

Bob McPherson, formerly of Canadian Broadcasting Corp. press and information department, named promotion manager of CTV Television Network Ltd., Toronto. He replaces **Ed Hausmann**, who is off on world trip with assignments for radio-TV coverage for various Canadian stations.

Royce Frith, Toronto moderator of CTV Television Network show *Telepoll*, appointed one of ten members of Canadian Royal Commission on Bilingualism and Biculturalism by Prime Minister Lester Pearson.

GOVERNMENT

Martin I. Levy, assistant chief of broadcast facilities division of FCC's Broadcast Bureau, named chief, succeeding **Wallace E. Johnson**, now assistant chief of Broadcast Bureau. Mr. Levy joined FCC in 1948 and served as chief of Broadcast Bureau's TV applications branch from 1957 to 1960. His post with broadcast facilities division has been filled by **Harold L. Kassens**, previously chief of Broadcast Bureau's aural facilities branch.

MEMO

To: NATIONAL & WESTERN REGIONAL ADVERTISERS
From: KD-HI . . . 29 PALMS, CALIFORNIA

With the *only* strong signal covering the two major arteries leading to and from Southern California, Highways 60/70 & 66, KD-HI offers a three way sales opportunity for aggressive advertisers.

CONSIDER THESE IMPRESSIVE FACTS IN RELATION TO YOUR SALES MESSAGE:

1. A million people travel through KD-HI land *every weekend* with boats, trailers and campers enroute to the great Colorado River and Southern California desert and water recreation areas.
2. KD-HI's signal is the *first California* radio station heard on *both* highways by the families traveling to our Golden State (10,000 *daily* passed through our signal area this past year). Here is a prime opportunity for you to convey your sales message and welcome.
3. KD-HI, 29 Palms, has a permanent audience of 30,000 and is the home of the worlds largest United States Marine Corps Base.

We feature top-quality Adult programming and are proud to be the only station (outside of Los Angeles and San Diego) to win the coveted Southern California "Golden Mike" Award for outstanding local news coverage and community service.

For rates, coverage maps and further information, Call: 367-2345 or write:

Art Sipherd
KD-HI Radio
P.O. Box 908
29 Palms, California

We invite rep inquiries as well.

**RADIO STATION
FORCED SALE!**

See page 79

Hamilton-Landis
& ASSOCIATES, INC.

EQUIPMENT & ENGINEERING

Frank B. Parrish, sales promotion manager of Gates Radio Co., Quincy, Ill., named advertising manager. Mr. Parrish joined Harris-Intertype Corp., parent company, in 1961.

Thomas Shea, eastern regional sales manager for Blonder-Tongue Laboratories, Newark, N. J., appointed to newly created post of closed circuit TV product manager. Mr. Shea joined Blonder-Tongue in 1954 as quality control technician.



Mr. Shea

John H. Bolendz joins Magne-Tronics as vice president and program director. Mr. Bolendz was formerly assistant program director at Muzak.

Josef C. Dine, director of information for CBS News, appointed director of information for CBS Laboratories, Stamford, Conn. Both are divisions of CBS Inc. Mr. Dine is former director of NBC press department. **Edward Foster**, former VP in charge of engineering for S.E.D. Memories, Bethel, Conn., joins CBS Labs as head of magnetic transducers section.

Robert Berkovitz, product manager for Dynaco Inc., Philadelphia, joins Jensen Manufacturing Co. (loudspeakers), Chicago, as product manager. Mr. Berkovitz formerly managed development and marketing of Knight high-fidelity equipment line for Allied Radio Corp., Chicago.

Dr. Jules S. Needle, manager of research and advanced development on O-type microwave tubes for Sylvania Electric Products, Mountain View, Calif., appointed to newly created position of chief engineer for power grid tube division of Eitel-McCullough Inc., San Carlos, Calif. Mr. Needle joined Sylvania in 1958.

Robert R. Owen, director of marketing for Jamieson Industries, Los Angeles, named south-central regional manager for Ampex Corp., with headquarters in Dallas, Tex.

William P. Howard, eastern sales manager of Comprehensive Service Corp., distributors of motion picture accessories and equipment, named sales manager of Movielab Inc., New York.

Joseph A. Gill, supervisor of personnel for lighting products plant of Sylvania Electric Products, named manager of industrial relations for home and commercial electronics division.

ALLIED FIELDS

Richard K. Lyon and **Seymour M. Chase**, Washington, D. C., communications attorneys, have established their own law firm, Lyon & Chase, at 700 Farragut Building, Washington 6. Telephone: 296-5066.

DEATHS



Mr. Cresap

Mark W. Cresap Jr., 53, who resigned three weeks ago as VP and chief executive officer of Westinghouse Electric Corp., Pittsburgh, for reasons of health (BROADCASTING, July 22), died July 28 at Presbyterian University Hospital in Pittsburgh. He underwent surgery previous day for gastric hemorrhage. Born in Chicago, Mr. Cresap joined Westinghouse in 1951 from Cresap, McCormick and Paget, a New York and Chicago management consultant firm he jointly founded with two former Navy officers. After four years as VP and assistant to Gwilyn A. Price, then Westinghouse Electric president, Mr. Cresap was elected executive VP, deputy chief executive officer and member of board of directors. He was elected president in 1958 and desig-

nated chief executive officer following year.

Marion Vilmure, 44, media buyer at Hal Stebbins Inc., Los Angeles advertising and PR firm, and past president of Advertising Women's Club of Los Angeles, died July 25 in St. Joseph's Hospital, Burbank, after brief illness.



Mr. Grabhorn

Murray B. Grabhorn, 62, former network and spot sales executive, died July 26 at his home in Bloomfield, N. J. Mr. Grabhorn was former ABC VP in charge of administration for owned and operated radio and television stations, and also had served as managing director of Station Representatives Association. Most recently he was assistant director of Multiple Sclerosis Society. Mr. Grabhorn was also associated with Hearst Broadcasting Stations, John Blair & Co., Edward Petry & Co., Paul H. Raymer Co. and Trans-American Broadcasting & Television Corp.

Herbert A. Rikles, 46, Northern California regional manager of *TV Guide* and former radio-TV writer, died July 24 at St. Francis Hospital in San Francisco after lengthy illness. Before joining magazine in 1948 as New York editor, Mr. Rikles wrote for Lanny Ross, Robert Q. Lewis and *Saturday Night Review* programs on radio, and Paul Winchell TV show.

Charter Heslep, 59, assistant to director of public information of Atomic Energy Commission and former newsman with NBC and MBS, died July 29 in Berkeley, Calif., hospital following heart attack. He was stricken while on business trip to AEC's offices in Albuquerque, N. M., and San Francisco. Mr. Heslep, a native of Richmond, Va., moved to Washington in 1929 as reporter for *Daily News* and rose to managing editor before leaving in 1941 for position with NBC as night news editor. During World War II he was chief radio news censor in office of censorship and in 1944 became Washington manager of Mutual Broadcasting System. Before joining AEC in 1949, Mr. Heslep served for year as executive editor of *Congressional News Quarterly*.



Mr. Heslep

SUBSCRIPTION APPLICATION

BROADCASTING *The Businessweekly of Television and Radio*

1735 DeSales Street, N.W., Washington, D. C., 20036

Please start my subscription immediately for—

- 52 weekly issues \$8.50 104 weekly issues \$14.00 Payment attached
 52 issues & 1964 Yearbook \$13.50 Please bill
 1963 Yearbook \$5.00 (so long as supply lasts)

name _____ title/position* _____

address Business Home _____

city _____ zone _____ state _____

company name _____

*Occupation Required

**RADIO STATION
FORCED SALE!**

See page 79

Hamilton-Landis
& ASSOCIATES, INC.

STATION AUTHORIZATIONS, APPLICATIONS

As compiled by BROADCASTING July 25 through July 31 and based on filings, authorizations and other actions of the FCC during that period.

This department includes data on new stations, changes in existing stations, ownership changes, hearing cases, rules and standards changes, routine roundup of other commission activity.

Abbreviations: DA—directional antenna. CP—construction permit. ERP—effective radiated power. VHF—very high frequency. UHF—ultra high frequency. ant.—antenna. aur.—aural. vis.—visual. kw—kilowatts. w-watts. mc—megacycles. D—day. N—night. LS—local sunset. mod.—modification. trans.—transmitter. unl.—unlimited hours. kc—kilocycles. SCA—subsidiary communications authorization. SSA—special service authorization. STA—special temporary authorization. SH—specified hours. *—educational. Ann.—Announced.

Existing TV stations

ACTIONS BY FCC

WGAL-TV Lancaster, Pa.—Granted renewal of license. Action July 30.
 KMID-TV Midland, Tex.—Waived Sec. 3.652(a) of rules to permit identification as Midland-Odessa. Comr. Bartley dissented. Action July 24.

New AM stations

ACTIONS BY FCC

Colorado Springs—William S. Cook. Granted CP for new AM on 1530 kc, 1 kw-D. P. O. address 4402 Marble Hall Rd., Baltimore 18, Md. Estimated construction cost \$23,325, first year operating cost \$12,000, revenue \$15,000. Applicant is electronic engineer, former 50% owner of WFDS-FM Baltimore, Md. June 6 initial decision looked toward grant. Action July 26.

Chattahoochee, Fla.—Chattahoochee Broadcasting Co. Granted CP for new AM on 1580 kc, 1 kw-D; remote control permitted. P. O. address c/o Emory L. Pope, P. O. Box 582, Moultrie, Ga. Estimated construction cost \$24,118; first year operating cost \$30,000; revenue \$36,000. Principals: Emory L. and Grady E. Pope and Ralph D. Waits Jr. (each 30%), W. F. Johnson and E. W. Scarborough (each 5%). E. L. Pope is 50% owner of WMES Ashburn, Ga.; Mr. Waits is newspaper employee; E. E. Pope owns insurance agency; Mr. Johnson is Chattahoochee postmaster and businessman; Mr. Scarborough is businessman.

Hastings, Minn.—Hastings Broadcasting Co. Granted CP for new AM on 1480 kc, 1 kw-D. P. O. address 839 West 5th St. Estimated construction cost \$20,400, first year operating cost \$52,000, revenue \$65,000. Principals: John G. McKane (51%) and John E. Hyde Jr. (49%). Mr. McKane is special project coordinator, Bureau of Information, Minnesota Department of Conservation. Mr. Hyde is half owner of KDHL Faribault, Minn., and has controlling interest in KSUM Fairmont, Minn. June 6 initial decision looked toward grant. Action July 26.

Prentiss, Miss.—Jeff Davis Broadcasting Service. Granted CP for new AM on 1510 kc, 1 kw-D, 250 w-CH. P. O. address 1018 Pope Street, Memphis 12, Tenn. Estimated construction cost \$12,360; first year operating cost \$34,500; revenue \$40,963. Jesse R. Williams is sole owner. Also see Ripley, Miss., grant below. Comr. Bartley abstained from voting. Action July 25.

Ripley, Miss.—Ripley Radio Service. Granted CP for new AM on 1260 kc, 500 w-D. P. O. address 1018 Pope Street, Memphis 12, Tenn. Estimated construction cost \$11,425; first year operating cost \$25,000; revenue \$33,875. Jesse R. Williams, sole owner, is civil service employee and garage owner. Also see Prentiss, Miss., grant above. Comr. Bartley abstained from voting. Action July 25.

Brownsville, Tenn.—Brownsville Broadcasting Co. Granted CP for new AM on 520 kc, 250 w-D. P. O. address Rt. 2, Box 103-A, Chattanooga, Tenn. Estimated construction cost \$14,011, first year operating cost \$30,000, revenue \$40,000. Roy Davis, sole owner, is farmer. June 3 initial decision looked toward grant. Action July 26.

Sutton, W. Va.—Braxton Broadcasting Company. Granted CP for new AM on 1490 kc, 250 w. P. O. address c/o Charles M. Erhard Jr., Box 38, Punxsutawney, Pa. Estimated construction cost \$11,350; first year operating cost \$35,600; revenue \$40,250. Principals: Sheridan W. Pruett and Charles M. Erhard Jr. (each 50%). Messrs. Pruett and Erhard own 51% and 2% respectively of WFME Punxsutawney, Pa. Comr. Cox dissented. Action June 24.

CALL LETTERS ASSIGNED

- WART Moulton, Ala.—Lawrence County Broadcasting Co.
- KGOL Palm Desert, Calif.—Palm Desert Broadcasting Co.
- KASC Santa Clara, Calif.—George B. Balrey.
- WGKR Perry, Fla.—Eugene Ketrig.
- KOLL Honolulu—Lawrence T. Kagawa.
- WKZI Casey, Ill.—Paul Dean Ford.
- WINV Highland, Ill.—Progressive Broadcasting Corp.
- WPMB Vandalia, Ill.—Peter-Mark Broadcasting Co.
- WHON Centerville, Ind.—Richmond Broadcasting Co.
- WGRB Greensburg, Ind.—Tree Broadcasting Co.
- WPHN Liberty, Ky.—Patrick Henry Broadcasting Co.
- WGHE Maplewood, Minn.—Ramsey Broadcasting Co.
- KFAV Rochester, Minn.—WBIZ Inc.
- KZIM Cape Girardeau, Mo.—Missouri-Illinois Broadcasting Co.
- KNBE Lincoln, Neb.—Lancaster County Broadcasting.
- WDSL Mocksville, N. C.—Wilkes Broadcasting Co.
- WNIO Niles, Ohio—Niles Broadcasting Co.
- WBTC Uhrichsville, Ohio—Tuscarawas Broadcasting Co.
- WWBR Windber, Pa.—Windber Community Broadcasting System.
- WPHC Waverly, Tenn.—Humphreys County Broadcasting Co.
- KDHN Dimmitt, Tex.—High Plains Broadcasting Co.
- KABH Midland, Tex.—Mid-Texas Broadcasting Co.
- WIKI Chester, Va.—Virginia Regional Broadcasters.
- WLCH Lynchburg, Va.—Griffith Broadcasting Corp.

Existing AM stations

ACTIONS BY FCC

KYOS Merced, Calif.—Granted renewal of license. Action July 30.
 KDHL Faribault, Minn.—Granted increased power on 920 kc, DA-2, unl., from 1 kw to 5 kw; conditions include precluding pre-sunrise operation with daytime facilities pending final decision in Doc. 14419. Comr. Ford dissented. Action July 24.

WRUL New York—Granted waiver of rules and authorized operating schedule of international broadcasting station on specified frequencies from Sept. 1 to Nov. 3, 1963. Action July 24.

WDAS Philadelphia—Granted renewal of license. Chmn. Henry abstained from voting. Action July 24.

WIP Philadelphia—Granted renewal of license without prejudice to whatever action, if any, may be taken by commission as result of disposition in WORZ Inc. v. FCC (Court of Appeals of District of Columbia), case No. 13,996. Action July 24.

WHPL Winchester, Va.—Granted increased operating hours from day to unl. time, with DA-2, continued operation on 610 kc, 500 w; engineering conditions. Action July 30.

New FM stations

APPLICATIONS

*Rolla, Mo.—Curators of University of Missouri. 88.5 mc, channel 203, 9.6 w. Ant. height above average terrain 66.5 feet. P. O. address c/o Dale O. Bowling, business manager, University of Missouri, Columbia, Mo. Estimated construction cost \$5,005; first year operating cost \$1,000. Principals are curators. Ann. July 30.

*Easton, Pa.—Lafayette College. 90.5 mc, channel 213, 10 w. Ant. height above average terrain 73 feet. P. O. address c/o David M. Lockett, director of student activities, Easton. Estimated construction cost \$6,500; first year operating cost \$3,440. Principals: board of trustees. Ann. July 30.

*Platteville, Wis.—Wisconsin State College & Institute of Technology. 89.5 mc, channel 208, 250 w. Ant. height above average terrain 117 feet. P. O. address c/o Bjarne R. Ullsvick, 709 West Main Street, Platteville. Estimated construction cost \$2,550; first year operating cost \$1,550. Principals: board of regents. Ann. July 26.

Existing FM station

APPLICATION

KBFM-FM Pampa, Tex.—CP to change studio location from 1421 North Hobart, Pampa, to 603 East Kenneth, Spearman, Tex.; change ant.-trans. location from 2.5 miles east of Pampa to same as studio, Spearman; and change station location from Pampa to Spearman. Ann. July 25.

Ownership changes

ACTIONS BY FCC

KNOG Nogales, Ariz.—Granted assignment of license from Madelon Harper Cowling (100%) to Richard H. Ward (100%). Consideration \$65,000. Mr. Ward is employe of WRGB-TV Schenectady, N. Y. Action July 30.

KNOT Prescott, Ariz.—Granted assignment of license and CP from Roy L. Albertson Jr. and Harold L. Sanner Jr. (each 50%), d/b as Thunderbird Broadcasting Co., to William H. Ellison (60%) and Myrl E. Parker (40%), tr/as Parkell Broadcasting Inc. Consideration \$35,000. Mr. Ellison has interest in KAMP El Centro, Calif.; Mr. Parker owns pharmacy. Action July 25.

KLIX Twin Falls, Idaho—Granted assignment of license from Paramor Corp. and Alhambra Corp. (each 50%), d/b as KLIX

EDWIN TORNBURG & COMPANY, INC.

Negotiators For The Purchase And Sale Of Radio And TV Stations Appraisers • Financial Advisors

New York—60 East 42nd St., New York 17, N. Y. • MU 7-4242
 West Coast—1357 Jewell Ave., Pacific Grove, Calif. • FR 5-3164
 Washington—711 14th St., N.W., Washington, D.C. • DI 7-8531



Corp., to William R. Vogel (70.7%), William H. Farnham (14%), Jack R. Caldwell (8.1%), W. O. Corrick (4.3%), Dean Harden (2.8%) and Darrell Chambers (.1%), tr/as Regional Broadcasting Corp. Consideration \$126,000. Applicant owns KWRV McCook, Neb., and WGNM Murfreesboro, Tenn. Action July 25.

WBSM-AM-FM New Bedford, Mass.—Granted transfer of control of license corporation, Bay State Broadcasting, from Maurice C. and Paul A. Duchaine, executors of estate of Joseph P. Duchaine (79.5%) and M. C. Duchaine (3.5% individually) to Murray Carpenter and George Gray (each 50%); 17% of stock now owned by Otto F. A. Arnold will be sold to Messrs. Duchaine for \$85,000 and they will sell 100%. Consideration \$395,000. Messrs. Carpenter (35%) and Gray (45%) and Chauncey L. Landon (20%) have application before commission now to buy WTCX St. Petersburg, Fla. and they propose to transfer WBSM-AM-FM to that corporation after FCC approval (see grant below). Action July 25.

WTYM East Longmeadow, Mass.—Granted transfer of control (and renewal of license) of licensee corporation, Executive Broadcasting Corp., from Stanley Ulanoff (30% plus) and others to Ralph C. Guild (59.65%). Peter D. Matthews (19.08%), Donald L. Wilks (11.82%) and Carleton F. Loucks (9.45%), tr/as New England Radio Corp. Consideration \$44,500. Mr. Guild is part owner of Daren F. McGavren Co., radio-TV rep firm; Mr. Matthews is businessman; Mr. Wilks works for McGavren company; Mr. Loucks is sales manager of WELI New Haven, Conn. Action July 29.

WBSM-AM-FM New Bedford, Mass.—Granted assignment of license from Bay State Broadcasting Corp. to Murray Carpenter and George Gray (each 50%), d/b as Southern Massachusetts Broadcasters Inc. (see grant above). Action July 25.

WHRV Ann Arbor, Mich.—Granted assignment of license from Clay Arthur S. (each 47.5%) and William O. Littick (5%), d/b as Zanesville Publishing Co., to Frank H. Babcock Jr. (50%), J. William & Dorothy O'Connor (each 23%), and Edward Ballantine & Thomas A. O'Connor (each 2%), tr/as Radio Ann Arbor Inc. Consideration \$295,000. Assignees have interest in WBOW Terre Haute and WHUT Anderson, both Indiana, WCVS Springfield, WPEO Peoria and WGSB Geneva, all Illinois, and KASK-AM-FM Ontario, Calif. Comr. Bartley dissented. Action July 24.

WGTC-AM-FM Greenville, N. C.—Granted transfer of control of licensee corporation, WGTC Broadcasting Co., from A. W. Lewin (100%) to Roy H. Park (100%), tr/as Roy H. Park Radio Inc., wholly owned subsidiary of Roy H. Park Broadcasting Inc. Consideration \$116,885. Mr. Park owns WNCT(TV) Greenville and 30% of WECT (TV) Wilmington, N. C., and KREB Shreveport, La. Action July 25.

WPXY Greenville, N. C.—Granted assignment of CP from John S. Townsend and others, d/b as H & R Electronics Inc., to Stanley H. Fox (35%), Seymour L. Dworsky (25%), Irvin L. & S. H. Fox (each 15%) and Milton A. Hight (10%), tr/as Bell Broadcasting Corp. Consideration \$34,071. Principals are owners of WRMT Rocky Mount and WIZS Henderson, both North Carolina. Action July 25.

WCOY Columbia, Pa.—Granted assignment of license from Donald W. and Joan G. Huff (100% as joint tenants), d/b as Radio Columbia Inc., to Jimmie Lee Putbrese (45%), Harold H. Hersch & Harold J. Sells (each 13%), W. T. Merchant Jr. and Samuel J. Cole (each 12%) and Charles E. Putbrese (5%), tr/as Tri-Cities Broadcasting Corp. Consideration \$66,500. Messrs. Hersch, Cole and Merchant are part owners of WPRW-AM-FM Manassas, Va., and WQVA Quantico, Va. Action July 25.

KOKE Austin, Tex.—Granted assignment of license from Giles E. Miller (100%), d/b as Radio KOKE Inc., to David R. Worley (100%). Consideration \$110,000. Mr. Worley owns KLEA Lovington, N. M. and 50% of KWBA Baytown, Tex. Action July 26.

WPVA Colonial Heights-Petersburg, Va.—Granted assignment of license from Harry A. Epperson Jr. (100%) to James C. Davis, John T. Minges, Bella S. Bowers, Norman J. Suttles and Derwood H. Godwin (each 20%), tr/as Smiles of Virginia Inc. Con-

sideration \$148,000. Assignees have interest in WISP Kinston, WFBS Spring Lake and WNOH Raleigh, all North Carolina. Action July 26.

APPLICATIONS

KFIF Tucson, Ariz.—Seeks assignment of license from R. E. Pruitt Jr. (70%) and John F. Badger (30%), d/b as Southwest Broadcasting Co., to Mr. Pruitt (100%), tr/as KFIF Broadcasting Corp. Consideration \$5,000 and assumption of debt. Ann. July 29.

WJDX-AM-FM Jackson, Miss.—Seeks assignment of licenses and SCA from John S. (18.2%), C. W. (7.48%) and C. W. Murchison Jr. (12.73%) and others, d/b as Lamar Life Insurance Co., to Peter K. Lutken Sr. (40%) and W. Calvin Wells III, Maurice Thompson and Fred L. Beard (each 20%), tr/as Lamar Life Broadcasting Co. Consideration \$25,000. Assignee is licensee of WLBT(TV) Jackson. Lamar Life Insurance retains ownership of physical plant of WJDX-AM-FM. Mr. Lutkin is chairman of board of Lamar Life Insurance. Ann. July 26.

KPBM Carlsbad, N. M.—Seeks transfer of control of licensee corporation, Coronado Broadcasting Inc., from Hazel H. McEvoy and family (66 2/3%) to Radio Carlsbad Inc., which is owned by Darrell A. Swayze (99.92%), present 33 1/2 owner of Coronado, Blanche A. Swayze and T. E. Lusk (each .04%). Consideration \$70,000. Mrs. Swayze is housewife; Mr. Lusk is attorney. Also see application below. Ann. July 26.

KPBM Carlsbad, N. M.—Seeks assignment of license from Coronado Broadcasting Inc. to Radio Carlsbad Inc. For other information see application above. Ann. July 26.

WALK Patchogue, N. Y.—Seeks assignment of license from W. K. Macy family (100%), d/b as Suffolk Broadcasting Corp., to William W. Mulvey, Jerome Feniger, Chester R. Huntley and Edward W. Wood Jr. (each 25%), tr/as Island Broadcasting System (WALK-AM) Inc. Consideration \$127,200. Mr. Wood is national sales manager of Screen Gems Industrial Productions, division of Screen Gems Inc.; Mr. Feniger is employed by Cowles Magazines and Broadcasting Inc.; Mr. Huntley is NBC news commentator; Mr. Mulvey is senior vice president of McCann-Erickson advertising agency. Assignee has also applied to buy WALK-FM and WRIV Riverhead, N. Y. (see those applications). Ann. July 26.

WALK-FM Patchogue, N. Y.—Seeks assignment of license and SCA from Suffolk Broadcasting Corp. to Island Broadcasting System (WALK-FM) Inc. Consideration \$39,200. For other information see WALK application above. Ann. July 26.

WRIV Riverhead, N. Y.—Seeks assignment of license from Suffolk Broadcasting Corp. to Island Broadcasting System (WRIV) Inc. Consideration \$51,100. For other information see WALK Patchogue, N. Y., application above. Ann. July 26.

WOHO Toledo, Ohio—Seeks transfer of control of licensee corporation, Midwestern Broadcasting Co., from Sebastian N. Sloan (37.48%) to Samuel W. Sloan (22.48% individually and 37.48% as executor of estate of S. N. Sloan). No financial consideration involved. Ann. July 30.

WXCN(FM) Providence, R. I.—Seeks assignment of license from William C. Hillman and Calvert C. Groton, receivers, to Howard M. Johnson (80%) and Karl S. Kritz (20%), tr/as Mallard Broadcasting Corp. Consideration \$35,000. Mr. Johnson owns sign and outdoor advertising companies; Mr. Kritz is WXCN general manager. Ann. July 31.

KBUY Amarillo, Tex.—Seeks transfer of control of licensee corporation, Radio KBUY Inc., from G. E. Miller & Co. to stockholders of Miller & Co. No financial consideration involved. Also see KPCN Grand Prairie, Tex., application below. Ann. July 29.

KTXN(TV) Austin, Tex.—Seeks assignment of CP from John R. Powley (50%), Robert D. Ballard (25%), Charles F. Schneider (12.5%) and Charles W. Pittman and Perry L. Blankenship (each 6.25%), d/b as Texas Longhorn Broadcasting Corp., to John R. Kingsbery, R. E. Jones Jr., Bryant M. Collins, Victor L. Brooks, and Texas Longhorn Broadcasting (each 10%) and E. G. Kingsbery (17.5%), John W. Stayton (15%), Allen B. Heard and

Roderick E. Kennedy (each 6.25%) and Marion B. Findlay (5%), tr/as Southwest Republic Corp. Consideration assumption of debt and issuance of 10% of stock to Longhorn. New principals are local business and professional men. Ann. July 31.

KPCN Grand Prairie, Tex.—Seeks transfer of control of licensee corporation, Radio KPCN Inc., from G. E. Miller & Co. to stockholders of Miller & Co. No financial consideration involved. Also see KBUY Amarillo, Tex., application above. Ann. July 29.

KARO(FM) Houston—Seeks assignment of license and SCA from E. F. Weerts (51%) and A. L. Herzog (49%), d/b as Multi-Casting Inc., to J. T. Trotter (65%), Ronald G. Schmidt (20%) and Joseph L. Brown Jr. (15%), tr/as Apollo Broadcasting Co. Consideration \$40,000. Mr. Trotter is attorney and businessman; Mr. Schmidt is past program director of KODA(FM) Houston; Mr. Brown is part owner of record shop Ann. July 25.

WVWV Grafton, W. Va.—Seeks acquisition of positive control of licensee corporation, WVWV Inc., from J. P. Beacom (50% before transfer, 30% after) by Patrick W. and Jean S. Larkin (each 25% before, each 35% after). Consideration \$13,200. Ann. July 26.

Hearing cases

INITIAL DECISIONS

■ Hearing Examiner H. Gifford Irion issued initial decision looking toward granting application of Helix Broadcasting Co. for new AM on 1520 kc, 500 w-N, 1 kw-L5, DA-2, at La Mesa, Calif.; condition. Action July 25.

■ Hearing Examiner David I. Kraushaar issued initial decision looking toward granting application of KPLT Inc. to increase daytime power of KPLT Paris, Tex., on 1490 kc from 250 w to 1 kw, continued nighttime operation with 250 w; conditions. Action July 25.

DESIGNATED FOR HEARING

WTAQ La Grange, Ill.—Designated for hearing application to increase daytime power on 1300 kc, DA-2, from 1 kw to 5 kw, continued nighttime operation with 500 w; made WMIL Milwaukee, WOOD Grand Rapids, Mich., WHLT Huntington, Ind., WKAN Kankakee, Ill., and WMRO Aurora Ill., parties to proceeding. Action July 24.

WETC Wendell-Zebulon, N. C.—Designated for hearing application to increase power on 540 kc, D, from 250 w to 5 kw with DA; made WYNN Florence, S. C. party to proceeding. Action July 24.

Coastal Cities Broadcasting Inc. Mos Point, Miss.—Designated for hearing application for new daytime AM on 1460 kc 1 kw, DA; made WNPS New Orleans, which filed opposing petition, and WAIL Bator Rouge, La., parties to proceeding. Comr Bartley dissented. Action July 24.

■ By memorandum opinion and order commission designated for hearing application by Raul Santiago Roman for new daytime AM on 1460 kc, 500 w, DA, at Veg; Baja, P. R.; made WMNT Manati, which filed opposing petition, and WMDD Fajard; parties to proceeding; issues include determination (a) as to whether applicant for transfer of control of WMNT filed by Paul Santiago Roman and Zaida Santo; Rivera, transferors, contained omissions of material facts, and (b) character qualifications of Roman. Action July 24.

■ By order, commission, on remand by court of appeals, designated for hearing applications of WEAT-TV Inc. and Scripps-Howard Radio Inc. to change trans. locations of WEAT-TV (ch. 12) and WPTV (TV) (ch. 5), respectively, both West Palm Beach Fla.; made Wometco Enterprises Inc (WTVJ|TV| ch. 4), Miami, which appealed commission's Feb. 14 and 21, 1962, grants of applications, party to proceeding. By separate memorandum opinion and order, commission denied Wometco's "petition for implementation" of court of appeals decision and (2) authorized WEAT-TV and WPTV (TV) to continue present operations without prejudice to such action as commission may deem necessary after decision in hearing proceeding. Action July 24.

OTHER ACTIONS

■ By supplement to third report and order in Doc. 14185, commission modified action of July 25 in adopting table of FM

broadcast channel assignments to change following four community assignments—Battle Creek, Mich., to channel 277; Cadillac, Mich., to channels 225 and 278; Sturgis, Mich., to channel 257A and Columbia City, Ind., to channel 292A. Necessitates modifying licenses of two existing stations at request: WELL-FM, now channel 243, Battle Creek, to shift to channel 277, and WSTR (FM), now channel 276, Sturgis, Mich., to go to channel 257A. Action is in response to late filing by WELL-FM and is based upon consideration of interference to WILX-TV and WMSB-TV (sharing time on channel 10) in Onondaga, if WELL-FM operated on FM channel 243. Comr. Cox dissented. Action July 30.

■ By order, commission scheduled oral argument for Sept. 19 on various petitions for reconsideration of May 29 report and order which denied short-spaced VHF channels for Johnstown, Pa.; Baton Rouge, La.; Dayton, Ohio; Jacksonville, Fla.; Birmingham, Ala.; Knoxville, Tenn., and Charlotte, N. C. Action July 30.

■ By memorandum opinion and order, commission (1) denied petitions by Valley Broadcasting Co. (KIVA, ch. 11), Yuma, Ariz., directed against commission's April 10 grants without hearing of applications for new TV stations of Tele-Broadcasters of California Inc. on channel 9 and KXO-TV Inc. on channel 7, both in El Centro, Calif., and (2) dismissed as moot requests for stay of grants. Commission feels facts upon which petitioner relies are too inconclusive and generally stated to show prima facie that grant of applications in inconsistent with prior made findings that they would serve public interest, convenience and necessity. Comr. Cox dissented. Action July 30.

■ By memorandum opinion and order, commission (1) waived Sect. 4.371(c) of rules and granted applications of Frontier Broadcasting Co. (license of KSTV-TV, ch. 10, Scottsbluff, Neb., and KFBC-TV, ch. 5, Cheyenne, Wyo.) for four new UHF TV translator stations on channels 70 and 72 at Borie, Wyo., and channels 81 and 83 at Albin, Wyo., and two new VHF TV translator stations on channels 2 and 6 at Scottsbluff; subject to non-duplication condition, and (2) denied opposing petition by Collier Electric Co. Action July 30.

■ By memorandum opinion and order, commission waived Sects. 3.610 and 3.685 of rules to permit Cimarron Television Corp. to operate KOCO-TV, ch. 5, at Oklahoma City ant. farm at short spacing with KFSATV on same channel at Fort Smith, Ark. Cimarron petitioned for change in commission's action of May 29 which reassigned channel 5 from Enid to Oklahoma City and required KOCO-TV to move from Enid to Oklahoma City accordingly. Action is based upon special facts in particular case—namely, inability to find site meeting air space requirements so as to serve both Oklahoma City and Enid, small mileage difference (about 14 miles), absence of significant impact on UHF development, and need for expeditious action to improve KOCO-TV's public service. Grant is subject to conditions specified in paragraph 17 of May 29 order, and construction at Oklahoma City is not to commence until specifically authorized by commission. Comr. Lee dissented; Comr. Loevinger issued concurring statement. Action July 25.

■ By memorandum opinion and order, commission denied petitions by Warwick Manufacturing Corp. and Zenith Radio Corp. requesting reconsideration of part of commission's second report and order of March 27 on fostering expanded use of UHF TV channels which related to ratio of vis. o aur. power for TV stations operating on channels 14-83. Action July 25.

■ Commission announced action adopting memorandum opinion and order denying petition by KGMO Radio-Television Inc. (KGMO), Cape Girardeau, Mo., for reconsideration of March 13 action which granted application of Missouri-Illinois Broadcasting

Co. for new daytime AM on 1220 kc, 250 w, in Cape Girardeau, and which dismissed as moot KGMO request for stay of March 13 grant. Chrm. Henry and Comr. Cox dissented with statements. Action July 25.

■ Commission returned as unacceptable for filing application by Capitol Television Inc. for three-year trial of MELCO pay-TV system over KVUE-TV (ch. 40) Sacramento, Calif., which has been off air since March 19, 1960. Action July 25.

■ By order in proceeding on applications of Spanish International Television Inc., Progress Broadcasting Corp., Bartell Broadcasters Inc. and Trans-Tel Corp. for new TV stations on channel 37 in Paterson, N. J., commission (1) granted petition by Progress to defer proceedings until completion of rulemaking affecting channel 37 in Doc. 15022; and (2) stayed hearing proceeding and ordered action upon all pending motions and other matters filed by parties, including those pending before hearing examiner and Review Board, shall be held in abeyance pending further order of commission. Comrs. Lee and Cox dissented; Comr. Ford not participating. Action July 24.

■ By memorandum opinion and order, commission denied application by Magic City Broadcasting Corp. for reconsideration and grant without hearing of application for additional time to construct WJBM Birmingham, Ala.; also denied Magic City's application for review of April 16 action by Review Board upholding examiner's denial of continuance of hearing. Comr. Cox not participating. Action July 24.

■ By order in KOB-WABC "770 kc" proceeding commission granted petition by American Broadcasting-Paramount Theatres Inc. to extent of staying 30-day period specified in July 8 decision for filing of DA proposal by WABC. Stay is until final court order concluding judicial review. Comrs. Cox and Loevinger not participating. Action July 24.

■ Commission scheduled oral argument for Sept. 9 on petition by KWK Radio Inc. for reconsideration of May 29 decision revoking license of KWK St. Louis. Comrs. Bartley, Cox and Loevinger not participating. Action July 24.

■ By order, commission granted request for waiver of Sect. 1.354(j)(2) of rules and accepted for filing amendments substituting Esther Morris, executrix of estate of Carleton W. Morris (in lieu of Mr. Morris) as applicant for new AM stations in Safford (1480 kc, 1 kw, unl.) and Winslow (1010 kc, 500 w-N, 1 kw-LS, DA-2), both Arizona. Comr. Bartley dissented. Action July 24.

■ By memorandum opinion and order, commission (1) granted application by Music Productions Inc. for extension of time to Oct. 31 to complete construction of WBVA Waynesboro, Va., and (2) denied petition of WAYB Waynesboro to deny extension application and also then pending application for assignment of WBVA construction permit to W. Courtney Evans (since dismissed). Comr. Bartley dissented. Action July 24.

■ Commission waived Sect. 3.610 of co-channel mileage separation rule and granted applications of (1) Meyer Broadcasting Co. to change trans. location of KFVR-TV (ch. 5) Bismarck, N. D., from about 12 miles east of city to about 12 miles south thereof, in direction of Glendive, increase ant. height from 500 feet to 1,430 feet, and decrease vis. ERP from 100 kw to 51.8 kw, with aur. ERP 31 kw, and (2) Glendive Broadcasting Corp. to change trans. location of KXGN-TV (ch. 5) Glendive, Mont., from site in city to point 4 miles southeast thereof, in direction of Bismarck, increase ant. height from 90 feet to 500 feet, and increase vis. ERP from 5 kw to 14.8 kw, with aur. ERP 7.4 kw. By letter, denied objections by Association of Maximum Service Telecasters Inc. Chrm. Henry abstained from voting; Comr. Lee dissented. Action July 24.

■ By memorandum opinion and order, commission denied petition by Brainerd Broadcasting Co. (KLIZ), Brainerd, Minn., to designate for hearing application of Greater Minnesota Broadcasting Co. for new AM on 1340 kc, 250 w, unl., in Brainerd and to consolidate it with proceeding on KLIZ application for change on 1380 kc from 1 kw-D, to 5 kw, DA-N, unl., in Doc. 14958. Action July 24.

■ By memorandum opinion and order, commission denied petitions by WAEB Broadcasters Inc. (WAEB), Allentown, Pa.,

Berkshire Broadcasting Corp. (WLAD), Danbury, Conn., New Broadcasting Inc. (WLIB), New York and Middlesex Broadcasting Co. (WCNX), Middletown, Conn., for reconsideration of Feb. 5, 1962, further supplement to report and order in Doc. 6741 which amended Sect. 1.351 of rules by adopting criterion to govern acceptance and processing of applications for new or changed AM facilities on channels adjacent to clear channels. Commission feels, since each proposal must be considered on own merits and number of such cases is small, it appears preferable to grant waivers where appropriate rather than make general change in rules at this time. By separate letters, commission granted waivers of Sect. 1.351(b)(2)(i) of rules and placed following applications in line for processing in normal course: WLAD on 800 kc, D, from 250 w to 1 kw; WLIB, on 1190 kc, limited, from 10 kw to 10 kw, DA, and WCNX, on 1150 kc, D, from 500 w to 1 kw. Request by WAEB for waiver of section will be considered in connection with hearing in Doc. 14165. Action July 24.

■ By letter, commission, on own motion, waived Sect. 1.354 of AM "freeze" rules and accepted for filing application of Radio Tennessee Inc. for mod. of license to change identification of WGYW Fountain City, Tenn. (1430 kc, 1 kw-D), to Knoxville. Fountain City has become annexed to Knoxville. Action July 24.

■ By letter, commission, on own motion, waived Sect. 1.354 of AM "freeze" rules and accepted for filing application of WROL Inc. to increase daytime power of WROL Fountain City, Tenn. on 1490 kc, from 250 w to 1 kw, continued nighttime operation with 250 w, and change designation of station location to Knoxville. Action July 24.

■ By order, commission (1) accepted for filing application of C. Edwin Goad for new FM on 99.1 mc; ERP 5.95 kw; ant. height 155.1 feet in Riverside, Calif. (facilities now assigned KPLI(FM), and which has pending application for renewal of license); and (2) waived Sect. 1.356 of FM "freeze" rules to extent necessary to permit acceptance for filing other applications specifying sub-

FOR TOWERS of all kinds CALL ROHN

For a complete line of towers ideally suited for radio, television and microwave use of all kinds, rely on ROHN.

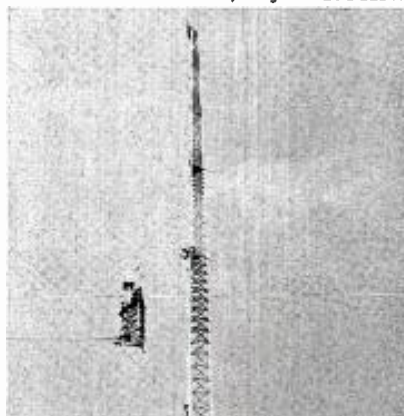

Shown above is the final installation of a 16 bay antenna atop a 485' ROHN TV broadcast tower. The installation is the WMBD-TV translator station at LaSalle, Illinois, Channel 71.

ROHN Manufacturing Co.

P. O. Box 2000
Peoria, Illinois

"Pioneer Manufacturer of
Towers of All Kinds"
ROHN Representatives world-wide.



McHugh and Hoffman, Inc.

Consultants for

TV—Radio • Networks—Stations
Advertisers—Agencies

470-2 N. Woodward—Birmingham, Mich.
Area Code 313 • 644-9200

stantially same facilities as proposed in Goad's application, provided applications are complete and tendered for filing on or before 5:00 p.m., Aug. 26. Action July 24.

■ By memorandum opinion and order, commission denied petition by WPRY Radio Broadcasters Inc. (WPRY), Perry, Fla., for stay of May 7 action which granted application of Eugene Ketring for new daytime AM (WGKR) on 1310 kc, 1 kw, in Perry. Action July 24.

■ By letter, commission withheld action for period of 30 days on application of Lake Huron Broadcasting Corp. for new AM on 1070 kc, 10 kw, DA-1, unli., in Houston, to permit filing of amendment which will clearly demonstrate compliance with North American Regional Broadcasting Agreement, since present proposed operation would not afford adequate protection to CMAB Pinar del Rio, Cuba, and therefore is in contravention of NARBA. Comr. Cox abstained from voting. Action July 24.

■ Commission granted applications of Midwest Program on Airborne Television Instruction Inc. for two new UHF TV translator stations on channels 81 and 83 to serve Cleveland by rebroadcasting programs of airborne experimental educational stations KS2XGA and KS2XGD at Montpelier, Ind. Translator stations will enable Cleveland area viewers to receive satisfactory pictures of airborne transmissions. Channel 81 grant is conditioned on cessation of translator operation upon commencement of regular operation of TV station on channel 67 at Warren, Ohio, or at other location involving short-spaced separations. Action July 24.

Routine roundup

ACTIONS BY REVIEW BOARD

■ By memorandum opinion and order in consolidated proceeding on applications of WIDU Broadcasting Inc. and Al-Or Broadcasting Co. for new AM stations in Asheville and Mebane, respectively, both North Carolina, in Docs. 14581-2. (1) held in abeyance applicants joint petition and supplement for approval of agreement whereby WIDU would be reimbursed \$12,000 for expenses incurred in connection with application in return for withdrawal, and (2) afforded parties opportunity to Sept. 1 to supplement showing as to unsubstantiated expenses. Board Member Berkemeyer dissented and issued statement. Action July 30.

■ By memorandum opinion and order in proceeding on application of Dixie Radio Inc. for new AM in Brunswick, Ga., in Doc. 13338, (1) denied petition by Broadcast Bureau to reopen record and enlarge issues; and (2) amended designation order to include condition that, in event of grant of Dixie application, CP shall contain condition that program tests will not be authorized until permittee has shown Denver T. Brannen (99.4% stockholder in Dixie) has divested all interest in, and severed all connections with, WFAP Fernandina Beach, Fla. Action July 29.

■ Granted petition by Leader Broadcasting Co., Edwardsville, Ill., to extend time to Aug. 30 to file exceptions to initial decision in proceeding on AM application and that of Salem Broadcasting Co. (WJBD), Salem, Ill. Action July 29.

■ By memorandum opinion and order, denied late filed petition by Broadcast Bureau to enlarge hearing issues in proceeding on AM application of Golden Triangle Broadcasting Inc. (WEEP), Mt. Oliver, Pa., in Doc. 14951. Action July 26.

■ Granted petition by Mitchell Broadcasting Co. to extend time to Aug. 5 to file exceptions to initial decision in proceeding on application for new AM in Estherville, Iowa. Action July 26.

■ By memorandum opinion and order in proceeding on application of Rhinelander Television Cable Corp. for new daytime AM on 1300 kc, 5 kw, at Rhinelander, Wis., denied Rhinelander's petition to extent that requests deletion of hearing issue 1 and dismissed petition to extent that requests license for respondent Oneida Broadcasting Co. (WOBT). Rhinelander, be called up for early renewal and character issue concerning WOBT be included in proceeding. Action July 25.

■ Granted petition by Broadcast Bureau to extent of extending to Aug. 16 time to file exceptions to initial decision in proceeding on AM application of People's

Broadcasting Co. (WPBC), Minneapolis. Action July 24.

■ Scheduled oral argument for Sept. 6 in proceeding on applications of Five Cities Broadcasting Co. and Douglas County Broadcasting Co. for new AM stations in Austell and Douglasville, respectively, both Georgia, in Docs. 14736-7. Action July 24.

ACTIONS ON MOTIONS

■ Commission, by office of opinions and review, granted petition by Tenth District Broadcasting Co. to extend time from July 26 to July 29 to file exceptions to initial decision in proceeding on application and that of Seven Locks Broadcasting Co. for new AM stations in McLean, Va., and Potomac-Cabin John, Md. Action July 29.

By Chief Hearing Examiner
James D. Cunningham

■ Designated Examiner Forest L. McClenning to preside at hearing in matter of revocation of licenses of Quality Broadcasting Corp. (WKYN), San Juan, Supreme Broadcasting Inc. (WFQM(FM)), San Juan, and Radio Americas Corp. (WORA-FM), Mayaguez, all Puerto Rico; scheduled prehearing conference for Sept. 16, in Washington, and hearing for Nov. 4, in San Juan. Action July 30.

■ Designated Examiner Arthur A. Gladstone to preside at hearing in proceeding on AM application of Wendell-Zebulon Radio Co. (WETC), Wendell-Zebulon, N. C.; scheduled prehearing conference for Sept. 12 and hearing for Oct. 1. Action July 29.

■ Designated Examiner Herbert Sharfman to preside at hearing in proceeding on AM application of Coastal Cities Broadcasting Inc., Moss Point, Miss.; scheduled prehearing conference for Sept. 12 and hearing for Oct. 1. Action July 29.

■ Granted petition by Broadcast Bureau to extent of extending time from July 29 to Aug. 9 to file proposed findings and ordering parties to adhere to Aug. 16 date heretofore specified to file reply findings in proceeding on application of Beamon Advertising Inc. for new AM in Daingerfield, Tex. Action July 29.

By Hearing Examiner Thomas H. Donahue

■ In proceeding on competing applications of Automated Electronics Inc., Arlington, Va., and Capital Broadcasting Co., Washington, for new TV stations on channel 20, granted petition by Capital to continue July 30 prehearing conference to Sept. 20. Action July 26.

By Hearing Examiner Charles J. Frederick

■ Granted motion by Central Wisconsin Television Inc. for extension of time from July 26 to Aug. 2 to file reply findings in proceeding on application for additional time to construct WCWT(TV) (ch. 9) Wausau, Wis., and for assignment of license to Midcontinent Broadcasting Co. Action July 26.

By Hearing Examiner Arthur A. Gladstone

■ Pursuant to agreements reached at July 24 further prehearing conference in Paterson, N. J., TV channel 37 proceeding, in Docs. 15089, et al., (1) ordered procedures to be followed in further conduct of proceeding shall be as set forth in stipulations and rulings entered upon transcript of further prehearing conference, and (2) postponed, without date, subject to further order, Sept. 9 hearing. Action July 24.

By Hearing Examiner Walther W. Guenther

■ Approved procedural ground rules established at July 26 prehearing conference in proceeding on AM application of Northland Radio Corp. (KWEB), Rochester, Minn., and continued Sept. 16 hearing to Oct. 29. Action July 26.

■ Granted motion by Bay Shore Broadcasting Co. to continue certain procedural dates and to continue July 29 hearing to Sept. 16 in proceeding on application for new AM in Hayward, Calif. Action July 26.

■ Granted petition by Broadcast Bureau for extension of time from Aug. 2 to Aug. 15 to file proposed findings and from Aug. 16 to Sept. 3 for replies in proceeding on application of Triangle Publications Inc. (WNHC-TV), New Haven, Conn. Action July 25.

■ Upon request by Finley Broadcasting Co. (KSRO), Santa Rosa, Calif., scheduled further hearing conference for July 25 in

proceeding on AM application of Bay Shore Broadcasting Co., Hayward, Calif. Action July 24.

By Hearing Examiner
Annie Neal Huntting

■ In proceeding on applications of Newton Broadcasting Co., Newton, and Transcript Press Inc., Dedham, both Massachusetts, in Docs. 13067-8, granted joint petition to extend time from July 29 to Sept. 10 to file proposed findings and from Aug. 30 to Sept. 24 for replies. Action July 29.

■ In consolidated AM proceeding on applications of Newton Broadcasting Co., Newton, and Transcript Press Inc., Dedham, both Massachusetts, in Docs. 13067-8, reopened record and scheduled further hearing for July 29 for purpose of considering joint petition by Newton Broadcasting Co. and Broadcast Bureau for extension of time to file proposed findings and replies. Action July 26.

By Hearing Examiner H. Gifford Irion

■ Issued statement and order governing hearing in consolidated AM proceeding on applications of Holston Broadcasting Corp., Elizabethton, and C. M. Taylor, Blountville, both Tennessee, in Docs. 15111-2, and scheduled certain procedural dates and continued Sept. 13 hearing to Oct. 2. Action July 26.

■ By order in Miami TV channel 10 proceeding, in Docs. 14775 et al., granted motion by Miami Television Corp. to extend time to Aug. 6 to file reply findings in Step 2, and to Aug. 26 to file such findings in Step 3. Action July 26.

By Hearing Examiner Jay A. Kyle

■ Granted request by Northern California Educational Television Association Inc. to continue July 30 hearing to Sept. 11 in proceeding on application for new non-commercial TV on channel 9 in Redding, Calif. Action July 30.

By Hearing Examiner
Chester F. Naumowicz Jr.

■ Granted petition by Lakewood Broadcasting Service Inc. (KLAK), Lakewood, Colo., for extension of time to Aug. 27 to reply to petition by Denver Area Broadcasters (KDAB), Arvada, Colo., for leave to amend AM application. Action July 29.

■ Upon request by Broadcast Bureau, extended to Aug. 6 and Aug. 16, respectively, dates to file proposed findings and replies in proceeding on AM application of Golden Triangle Broadcasting Inc. (WEEP), Mt. Oliver, Pa. Action July 25.

■ Granted request by Denver Area Broadcasters (KDAB), Arvada, Colo., to extend July 24 date for exchange of exhibits to 14 days after release date of hearing examiner's order disposing of prospective petition for leave to amend AM application. Action July 24.

BROADCAST ACTIONS by Broadcast Bureau

Actions of July 29

■ Granted renewal of licenses for following stations for normal license term: WAYZ-FM Waynesboro; WARD-FM Johnstown; WCED-FM Dubois; WBVP-FM Beaver Falls; WDJR(FM) Oil City, all Pennsylvania; WDEL-FM Wilmington, Del.; WEEZ-FM Easton; WEST-FM Easton; WHP-FM Harrisburg; WITT(FM) Pittsburgh; WIBG-FM Philadelphia; WGAL-FM Lancaster; WKOK-FM Sunbury; WLOA-FM Braddock; WLAN-FM Lancaster; WMGW-FM Meadville; WLBR-FM Lebanon; WPEN-FM Philadelphia; WLYC-FM Williamsport; WQAL(FM) Philadelphia; WPPA-FM Pottsville; WWSW-FM Pittsburgh; WRAC-FM Williamsport, all Pennsylvania; WGR-AM-FM Buffalo, N. Y.; WRRN(FM) Warren; WNOW-FM York; WVAM-FM Altoona, all Pennsylvania.

WIP-FM Philadelphia—Granted renewal of license for normal license term; without prejudice to whatever action, if any, may be taken by commission as result of disposition in WORZ Inc. v. FCC (Court of Appeals of District of Columbia), case No. 13,996.

WCAU-FM Philadelphia—Granted renewal of license, including auxiliary, for normal license term; without prejudice to such action as commission may deem warranted as result of final determinations: (1) with respect to conclusions and recommendations set forth in report of network study staff; (2) with respect to related studies and inquiries now being considered or conducted by commission; (3) with re-

PROFESSIONAL CARDS

JANSKY & BAILEY
 Offices and Laboratories
 1339 Wisconsin Ave., N.W.
 Washington 7, D.C. Federal 3-4800
Member AFCEE

JAMES C. McNARY
 Consulting Engineer
 National Press Bldg.
 Wash. 4, D. C.
 Telephone District 7-1205
Member AFCEE

—Established 1926—
PAUL GODLEY CO.
 Upper Montclair, N. J.
 Pilgrim 6-3000
 Laboratories, Great Notch, N. J.
Member AFCEE

GEORGE C. DAVIS
 CONSULTING ENGINEERS
 RADIO & TELEVISION
 527 Munsey Bldg.
 STerling 3-0111
 Washington 4, D. C.
Member AFCEE

**COMMERCIAL RADIO
 EQUIPMENT CO.**
 Everett L. Dillard, Gen. Mgr.
 Edward F. Lorentz, Chief Engr.
 INTERNATIONAL BLDG.
 Bl 7-1319
 WASHINGTON 4, D. C.
Member AFCEE

A. D. Ring & Associates
 41 Years' Experience in Radio
 Engineering
 1710 H St., N.W. 298-6850
 WASHINGTON 6, D. C.
Member AFCEE

GAUTNEY & JONES
 CONSULTING RADIO ENGINEERS
 930 Warner Bldg. National 8-7757
 Washington 4, D. C.
Member AFCEE

Lohnes & Culver
 Munsey Building District 7-8215
 Washington 4, D. C.
Member AFCEE

L. H. Carr & Associates
 Consulting
 Radio & Television
 Engineers
 Washington 6, D. C. Fort Evans
 1000 Conn. Ave. Leesburg, Va.
Member AFCEE

KEAR & KENNEDY
 1302 18th St., N.W. Hudson 3-9000
 WASHINGTON 6, D. C.
Member AFCEE

A. EARL CULLUM, JR.
 CONSULTING ENGINEERS
 INWOOD POST OFFICE
 DALLAS 9, TEXAS
 MElose 1-8360
Member AFCEE

GUY C. HUTCHESON
 P.O. Box 32 CRestview 4-8721
 1100 W. Abram
 ARLINGTON, TEXAS

**SILLIMAN, MOFFET
 & KOWALSKI**
 1405 G St., N.W.
 Republic 7-6646
 Washington 5, D. C.
Member AFCEE

GEO. P. ADAIR ENG. CO.
 CONSULTING ENGINEERS
 Radio-Television
 Communications-Electronics
 901 20th St., N.W.
 Washington, D. C.
 Federal 3-1116
Member AFCEE

WALTER F. KEAN
 CONSULTING RADIO ENGINEERS
 Associate
 George M. Sklom
 19 E. Quincy St. Hickory 7-2401
 Riverside, Ill. (A Chicago suburb)
Member AFCEE

HAMMETT & EDISON
 CONSULTING RADIO ENGINEERS
 Box 68, International Airport
 San Francisco 28, California
 Diamond 2-5208
Member AFCEE

JOHN B. HEFFELFINGER
 9208 Wyoming Pl. Hiland 4-7010
 KANSAS CITY 14, MISSOURI

**JULES COHEN
 & ASSOCIATES**
 9th Floor, Securities Bldg.
 729 15th St., N.W., 393-4616
 Washington 5, D. C.
Member AFCEE

CARL E. SMITH
 CONSULTING RADIO ENGINEERS
 8200 Snowville Road
 Cleveland 41, Ohio
 Phone: 216-526-4386
Member AFCEE

J. G. ROUNTREE
 CONSULTING ENGINEER
 P.O. Box 9044
 Austin 56, Texas
 GLendale 2-3073

VIR N. JAMES
 CONSULTING RADIO ENGINEERS
 Applications and Field Engineering
 232 S. Jasmine St.
 Phone: (Area Code 303) 333-5562
DENVER 22, COLORADO
Member AFCEE

A. E. Towne Assocs., Inc.
 TELEVISION and RADIO
 ENGINEERING CONSULTANTS
 420 Taylor St.
 San Francisco 2, Calif.
 PR 5-3100

PETE JOHNSON
 Consulting am-fm-tv Engineers
 Applications—Field Engineering
 Suite 601 Kanawha Hotel Bldg.
 Charleston, W.Va. Dickens 2-6281

MERL SAXON
 CONSULTING RADIO ENGINEER
 622 Hoskins Street
 Lufkin, Texas
 NEptune 4-4242 NEptune 4-9558

WILLIAM B. CARR
 Consulting Engineer
 AM—FM—TV
 Microwave
 P. O. Box 13287
 Fort Worth 18, Texas
 BUTler 1-1551

**RAYMOND E. ROHRER
 & Associates**
 Consulting Radio Engineers
 436 Wyatt Bldg.
 Washington 5, D. C.
 Phone: 347-9061
Member AFCEE

E. HAROLD MUNN, JR.
 BROADCAST ENGINEERING
 CONSULTANT
 Box 220
 Coldwater, Michigan
 Phone: BRoadway 8-6733

**JOHN H. MULLANEY
 and ASSOCIATES**
 A Division of Multronics, Inc.
 Multronics Building
 5712 Frederick Ave. Rockville, Md.
 (a suburb of Washington)
 Phone: 301 427-4666
Member AFCEE

**Service
 Directory**

**COMMERCIAL RADIO
 MONITORING CO.**
 PRECISION FREQUENCY
 MEASUREMENTS
 AM-FM-TV
 103 S. Market St.,
 Lee's Summit, Mo.
 Phone Kansas City, LaClede 4-3777

**CAMBRIDGE CRYSTALS
 PRECISION FREQUENCY
 MEASURING SERVICE**
 SPECIALISTS FOR AM-FM-TV
 445 Concord Ave.,
 Cambridge 38, Mass.
 Phone TRowbridge 6-2810

COLLECTIONS
 For the Industry
 ALL OVER THE WORLD
 TV—Radio—Film and Media
 Accounts Receivable
 No Collection—No Commission
 STANDARD ACTUARIAL
 WARRANTY CO.
 220 West 42nd St., N. Y. 36, N. Y.
 LO 5-5590

SUMMARY OF COMMERCIAL BROADCASTING

Compiled by BROADCASTING, July 31

	Lic.	ON AIR CP's	NOT ON AIR CP's	TOTAL APPLICATIONS for new stations
AM	3,810	50	153	341
FM	1,091	29	88	190
TV	522 ¹	53	85	115

OPERATING TELEVISION STATIONS

Compiled by BROADCASTING, July 31

	VHF	UHF	TOTAL TV
Commercial	484	91	578
Non-commercial	47	21	68*

COMMERCIAL STATION BOXSCORE

Compiled by FCC June 30

	AM	FM	TV
Licensed (all on air)	3,809	1,090	519
CP's on air (new stations)	51	30	56
CP's not on air (new stations)	137	87	85
Total authorized stations	3,997	1,207	660 ¹
Applications for new stations (not in hearing)	210	178	67
Applications for new stations (in hearing)	146	13	53
Total applications for new stations	356	191	120
Applications for major changes (not in hearing)	254	90	47
Applications for major changes (in hearing)	54	3	8
Total applications for major changes	308	93	55
Licenses deleted	0	2	0
CP's deleted	1	2	0

¹Does not include six licensed stations off air

*Includes three stations operating on unreserved channels

spect to pending antitrust matters relating to Columbia Broadcasting System Inc.; and (4) with respect to application of Sect. 3.658(a) and (c) of commission's rules to certain amendments to affiliation contracts proposed by CBS.

WJAS-FM Pittsburgh—Granted renewal of license for normal license term; without prejudice to such action as commission may deem warranted as result of final determinations: (1) with respect to conclusions and recommendations set forth in report of network study staff; (2) with respect to related studies and inquiries now being considered or conducted by commission; and (3) with respect to pending antitrust matters relating to National Broadcasting Co. and Radio Corp. of America.

K09AD Newcastle, Wyo.—Granted license covering changes for VHF TV translator station.

Actions of July 26

KWKC Abilene, Tex.—Granted increased daytime power on 1340 kc, from 250 w to 1 kw, continued nighttime operation with 250 w, and installation of new trans.; conditions.

KVRH Salida, Colo.—Granted increased daytime power on 1340 kc, SH, from 250 w to 1 kw, continued nighttime operation with 250 w, and installation of new trans.; conditions.

KTRF Thief River Falls, Minn.—Granted increased daytime power on 1230 kc, from 250 w to 1 kw, continued nighttime operation with 250 w, and installation of new trans.; conditions.

KAKE Wichita, Kan.—Granted licenses covering increase in daytime power (main); and use of old main trans. as aux., nighttime trans. at main trans. site.

K73AW Quitaque and Turkey, both Texas—Granted license for UHF TV translator station.

K07EX Bodenbug Butte Area and USBR Government Camp, both Alaska—Granted CP to replace expired permit for new VHF TV translator station and specify type trans.

K13BC Circle, Mont.—Granted CP to make changes in ant. system for VHF TV translator station.

K13AB Kadoka, S. D.—Granted CP to change type trans. and make changes in ant. system for VHF TV translator station.

K07FV Darby and Conner, both Montana—Granted CP to change frequency to channel 7 and make changes in ant. system for VHF TV translator station.

K75BD Weed Heights, Nev.—Granted CP to change frequency to channel 75, and primary station to KCRL(TV) (ch. 4) Reno for UHF TV translator station.

WNBE-TV New Bern, N. C.—Granted mod. of CP to change studio location to present trans. location and correct geographic coordinates; ant. height 730 feet.

K13DU Whitewater-Loring, Mont.—Granted mod. of CP to change type trans., make changes in ant. system and include Wynot and Lovejoy, both Montana in principal community for VHF TV translator station.

K11GA Valier, Mont.—Granted mod. of CP to change frequency to channel 11, type trans., trans. location and primary TV station to KRTV(TV) (ch. 3) Great Falls, Mont., make changes ant. system, and correct geographic coordinates for VHF TV translator station.

■ Granted licenses for following VHF TV translator stations: K02BR, K05BI, Escalante TV Association, Escalante, Utah, and change primary station call to KUTV(TV) for K05BI; W11AH, WMRC Inc., Tryon, N. C.; W02AD, Skyway Broadcasting Co., Waynesville and Hazelwood, both North Carolina; W08AF, WIIC Inc., Greensburg, Pa.; K13FL, Edward E. Schultz, Estes Park, Colo.

Actions of July 25

K0MC(TV) McCook, Neb.—Granted license for TV station; ERP 100 kw vis. and 50 kw aur.

KVLF-TV Alpine, Tex.—Granted license for TV station and redescribe trans. and studio locations.

WTOM-TV Cheboygan, Mich.—Granted license covering increase in ERP and change of type trans.

KWWL-TV Waterloo, Iowa—Granted license covering decrease in aur. ERP.

KVOO-TV Tulsa, Okla.—Granted license covering installation of aux. ant. at main trans. site.

***WEDH(TV) Hartford, Conn.**—Granted CP to change ERP to 131 kw vis. and 63 kw aur. and modify ant. to provide electrical beam tilt.

WPRO-TV Providence, R. I.—Granted CP to change ERP to 275 kw vis. and 138 kw aur., type ant. and make changes in ant. system (main trans. and ant.).

K11AD Loma, Mont.—Granted CP to change type trans. for VHF TV translator station.

■ Granted licenses covering changes for following TV stations: KREX-TV Western Slope Broadcasting Inc., Grand Junction, Colo.; KCTV(TV) Westex Television Co., San Angelo, Tex.

■ Granted CP's to replace expired permits for following new VHF TV translator stations: K07ES, Kanab Lions TV, Fredonia, Ariz.; K09EL, Ten Sleep Free TV Club, Ten Sleep, Wyo.; K04CK, Kanab Lions TV, Kanab, Utah.

Actions of July 24

WHOS-FM Decatur, Ala.—Granted SCA on subcarrier frequencies of 41 and 87 kc.

K0WL Bijou, Calif.—Granted increased daytime power on 1490 kc, from 250 w to 1 kw, continued nighttime operation with 250 w, and installation of new trans.; remote control permitted; conditions.

■ Granted renewal of licenses for following VHF TV translator stations for normal license term: K10AA, K12AB, Baker TV Booster Inc., Baker, Mont.; K02AO, Channel 4 TV Inc., Rexford-Gateway area, Mont.; K10AT, Circle TV Booster Club Inc., Circle, Mont.; K07AL, K13AC, Fort Benton TV Club, Fort Benton, Mont.; K11AN, K13AR, Glacier County TV Club Inc., Cut Bank, Mont.; K10AJ, Howard TV Club, Howard Mont. (rural community); K05BL, K13DF, Lame Deer Community TV Club, Lame Deer, Mont.; K10DB, North County TV Club, Opheim and Glentana, Mont.; K09DQ, K11EM, Pinkham Mountain TV Club, Glen Lake Area, Mont.; K10AB, Richland TV Club, Sidney, Mont.; K10BF, Shields River Free T.V. Association, Clyde Park, Wilsall and Upper Shields River, all Montana; K11AQ, K07AV, Stanford TV Association, Stanford, Mont.; K11DV, Upper Rosebud TV Club, Upper Rosebud, Mont.; K07AB, K11AC, Bert E. Williamson, Belt, Mont.; K06AV, Wolf Point TV Club, Wolf Point, Mont.

■ Granted renewal of licenses for following UHF TV translator stations for normal license term: K80AX, Blacktail T.V. Association, Big Fork, Mont.; K73AC, K82AB, Hill County T-V Club, Havre, Mont.; K77AN, Tea Kettle T.V. Association Inc., Columbia Falls, Mont.

WIVE Ashland, Va.—Granted license covering installation of new trans.

WRNL Richmond, Va.—Remote control permitted while using non-DA (alternate main trans.).

WRNL-FM Richmond, Va.—Remote control permitted (main and aux. trans.).

WDEA Ellsworth, Me.—Granted CP to replace expired permit to install old main trans. as aux. trans.

Revocations

■ Commission ordered Quality Broadcasting Corp., Supreme Broadcasting Inc., of Puerto Rico, and Radio Americas Corp. to show cause why licenses of commonly owned Puerto Rico stations WKYN San Juan, WFQM(FM) San Juan and WORA-FM Mayaguez should not be revoked, and to appear at hearing to be held in San Juan at time to be set later, for which they each face apparent liability up to \$10,000 if commission should impose forfeitures in lieu of license revocations. Quality and Supreme are controlled by Radio Americas, which latter corporation is, in turn, controlled by Alfredo R. de Arellano, Jr., who is president of all three corporations. Action July 25.

Rulemakings

FINALIZED

■ By separate report and orders, commission finalized rulemaking to give Atlanta and Ogden, Utah, second noncommercial educational TV channels, Channel 57 was deleted from Marietta, Ga., where it was

unused, and assigned Atlanta for educational use and noncommercial reservation was shifted from channel 24 to channel 9 at Ogden. Action July 30.

PROPOSED

■ Pursuant to proposed rulemaking of April 24, commission adopted expanded table of TV channel assignments for Puerto Rico and Virgin Islands to further development of UHF service in islands. New table follows: Puerto Rico: Aguadilla, *32, 44; Arcibo-Aguadilla, 12+; Arcibo, 54, 80; Bayamon, 36; Caguas, 11-, *58; Carolina, 52; Cayey, 76; Fajardo, 13+; *40; Guayama, 46; Humacao, 68; Mayaguez, *3+, 5-, 16, 22; Ponce, 7+, 9-, 14, 20, *26, 48; San Juan, 2+, 4-, *6+, 18, 24, 30, *74; San Sebastian, 38; Utuado, *70; Vega Baja, 64; Yauco, 42; Virgin Islands: Charlotte Amalie, 10-, 17, *23, 43; Christiansted, 8+, 15, *21, 27. Action July 30.

■ In notice of proposed rulemaking concerning certain requests for additional educational UHF TV channels, commission announced intention to issue further proposals in Doc. 14229 inviting comments on specific additions, deletions and changes in assignment of UHF TV channels 14 to 83 inclusive (none for VHF channels). Accordingly, but subject to changes which may be necessitated by UHF channel revisions, commission invited comments on following proposals, based upon petitions, for additional UHF educational reservations: Bay Area Educational Television Association, for channel 38 at San Francisco-Oakland, Calif.; Central California Educational Television, channel 46 or channel 19 at Sacramento, Calif.; Cabrillo College, channel 22, Watsonville, Calif.; John M. Sink, channel 20, Santa Barbara, Calif.; National Educational and Radio Center, channel 47 at Athens, Tenn., and channel 14 at Chattanooga, Tenn.; New Jersey Educational Television Corp., channel 52, Atlantic City; University of New Hampshire, channels 45 and 24 at Keene and Littleton, both New Hampshire, respectively; Georgia State Board of Education to make commercial channel 8 at Waycross, Ga., on which it operates WXGA-TV, noncommercial educational channel. Action July 30.

■ By notice of proposed rulemaking, commission invited comments to proposal by Charlottesville Broadcasting Corp. (licensee of WINA-AM-FM Charlottesville, Va.) to assign channel 11 plus to Staunton-Waynesboro, Va., on hyphenated basis. It would necessitate change of offset carrier of WTVD (TV) at Durham, N. C., from channel 11 plus to channel 11 even. Comr. Cox desisted; Comr. Loewinger abstained from voting. Action July 25.

PETITION FOR RULEMAKING FILED

■ WCRT-AM-FM Birmingham, Ala.—Requests amendment of rules to remove educational reservation from channel 48 and make channel available for commercial TV operation. Filed July 22.

Processing line

■ Notice is hereby given, pursuant to Sect. 1.354(c) of commission rules, that on Sept. 4, 1963, standard broadcast applications listed in appendix will be considered as ready and available for processing. Pursuant to Sect. 1.106(b)(1) and Sect. 1.361(c) of commission's rules, application, in order to be considered with any application appearing on attached list or with other application of file by close of business on Sept. 3, 1963, which involves conflict necessitating hearing with application on list, must comply with interim criteria governing acceptance of standard broadcast applications set forth in note to Sect. 1.354 of commission rules and be substantially complete and tendered for filing at offices of commission in Washington by whichever date is earlier: (a) close of business on Sept. 3, 1963, or (b) earlier effective cut-off date which listed application or other conflicting application may have by virtue of conflicts necessitating hearing with applications appearing on previous lists. Applications from top of processing line:

■ KFMB San Diego—Transcontinent Television Corp. From 540 kc, 5 kw, DA-N, unil, to 760 kc, 5 kw, DA-N, unil. (BMP-9905).

■ WENC Whiteville, N. C.—Whiteville Broadcasting Co. From 1220 kc, 1 kw-D to 1220 kc, 5 kw-D (BP-13390).

■ WLIB New York—New Broadcasting Inc. From 1190 kc, 1 kw, L-WOWO to 1190 kc, 10 kw, DA-1, L-WOWO (BP-13978).

■ KPUG Bellingham, Wash.—KPUG Inc. From 1170 kc, 1 kw, DA-1, unil. to 1170 kc, 10 kw, DA-1, unil. (BP-14162).

■ KZEY Tyler, Tex.—Tyler Broadcasting Co. From 690 kc, 250 w-D, DA to 690 kc, 1 kw-D, DA (BP-14702).

■ WCHA Chambersburg, Pa.—Chambersburg Broadcasting Co. From 800 kc, 1 kw-D to 800 kc, 5 kw-D (BP-14743).

■ KIBE Palo Alto, Calif.—Sundial Broadcasting Corp. From 1220 kc, 1 kw-D to 1220 kc, 5 kw-D.

■ WKDN Camden, N. J.—South Jersey Broadcasting Co. From 800 kc, 1 kw-D to 800 kc, 5 kw-D, DA (BP-14986).

■ WIZE Springfield, Ohio—Radio Voice of Springfield Inc. From 1340 kc, 250 w, unil. to 1340 kc, 250 w, 1 kw-LS, unil. (BMP-10563).

■ WFOR Hattiesburg, Miss.—Newforte Inc. From 1400 kc, 250 w, unil. to 1400 kc, 250 w, 1 kw-LS, unil. (BP-15722).

■ WHIT New Bern, N. C.—Ray D. Williams. From 1450 kc, 250 w, unil. to 1450, 250 w, 1 kw-LS, unil. (BP-15731).

■ KBST Big Spring, Tex.—Snider Corp. From 1490 kc, 250 w, unil. to 1490 kc, 250 w, 1 kw-LS, unil. (BP-15732).

■ WIRA Fort Pierce, Fla.—Indian River Broadcasting Co. From 1400 kc, 250 w, unil. to 1400 kc, 250 w, 1 kw-LS, unil. (BP-15740).

■ KDLR Devils Lake, N. D.—KDLR Inc. From 1240 kc, 250 w, unil. to 1240 kc, 250 w, 1 kw-LS, unil. (BP-15742).

■ KEXO Grand Junction, Colo.—Voice of Western Colorado Inc. From 1230 kc, 250 w, unil. to 1230 kc, 250 w, 1 kw-LS, unil. (BP-15743).

■ WSNT Sandersville, Ga.—Radio Station WSNT Inc. From 1490 kc, 250 w, 500 w-LS, unil. to 1490 kc, 250 w, 1 kw-LS, unil. (BP-15744).

■ WINK Fort Myers, Fla.—Fort Myers Broadcasting Co. From 1240 kc, 250 w, unil. to 1240 kc, 250 w, 1 kw-LS, unil. (BP-15745).

■ WFPR Hammond, La.—Airweb Inc. From 1400 kc, 250 w, unil. to 1400 kc, 250 w, 1 kw-LS, unil. (BP-15751).

■ WITB Vero Beach, Fla.—Tropics Inc. From 1490 kc, 250 w, unil. to 1490 kc, 250 w, 1 kw-LS, unil. (BP-15752).

■ WINA Charlottesville, Va.—Charlottesville Broadcasting Corp. From 1400 kc, 250 w, 1 kw-LS, unil. to 1070 kc, 5 kw, DA-N, unil. (BP-15768).

■ WLAJ LaFollette, Tenn.—LaFollette Broadcasting Inc. From 1450 kc, 250 w, unil. to 1450 kc, 250 w, 1 kw-LS, unil. (BP-15804).

■ WQXT Palm Beach, Fla.—Fairfax Broadcasting Inc. From 1340 kc, 250 w, unil. to 1340 kc, 250 w, 1 kw-LS, unil. (BP-15811).

■ KFTW Fredericktown, Mo.—Robert F. Neathery. From 1450 kc, 250 w, unil. to 1450 kc, 250 w, 1 kw-LS, unil. (BMP-10738).

■ KAOR Oroville, Calif.—James E. Wally. From 1340 kc, 250 w, unil. to 1340 kc, 250 w, 1 kw-LS, unil. (BP-15814).

■ KRUS Ruston, La.—Ruston Broadcasting Co. From 1490 kc, 250 w, 500 w-LS, unil. to 1490 kc, 250 w, 1 kw-LS, unil. (BP-15817).

■ Barbourville, Ky.—Golden East Broadcasting Inc. 1490 kc, 250 w, unil. (BP-15827).

■ KORN Mitchell, S. D.—Mitchell Broadcasting Association Inc. From 1490 kc, 250 w, unil. to 1490 kc, 250 w, 1 kw-LS, unil. (BP-15829).

■ KLTZ Glasgow, Ky.—Glasgow Broadcasting Co. From 1240 kc, 250 w, unil. to 1240 kc, 250 w, 1 kw-LS, unil. (BP-15830).

■ KKIV Phoenix, Ariz.—Camelback Broadcasting Inc. From 1400 kc, 250 w, unil. to 1400 kc, 250 w, 1 kw-LS, unil. (BP-15831).

■ Coolidge, Ariz.—Coolidge Broadcasting Co. 1150 kc, 1 kw, DA-N, unil. (BP-15838).

■ John Day, Ore.—John Day Valley Broadcasters. 1400 kc, 250 w, unil. (BP-15841).

■ WRO Ironton, Ohio—Tri-Radio Broadcasting Co. From 1230 kc, 250 w, unil. to 1230 kc, 250 w, 1 kw-LS, unil. (BP-15843).

■ KBIX Muskogee, Okla.—Oklahoma Press Publishing Co. From 1490 kc, 250 w, unil. to 1490 kc, 250 w, 1 kw-LS, unil. (BP-15844).

■ KORA Bryan, Tex.—Bryan Broadcasting Inc. From 1240 kc, 250 w, unil. to 1240 kc, 250 w, 1 kw-LS, unil. (BP-15854).

■ KIKO Miami, Ariz.—Willard Shoecraft.

From 1340 kc, 250 w, unil. to 1340 kc, 250 w, 1 kw-LS, unil. (BP-15856).

■ KDWT Stamford, Tex.—ABKO Broadcasting Co. From 1400 kc, 250 w, unil. to 1400 kc, 250 w, 1 kw-LS, unil. (BP-15857).

■ KTNM Tucumcari, N. M.—Tucumcari Broadcasting Inc. From 1400 kc, 250 w, unil. to 1400 kc, 250 w, 1 kw-LS, unil. (BP-15858).

■ KAAA Kingman, Ariz.—Wallace E. Stone. From 1230 kc, 250 w, unil. to 1230 kc, 250 w, 1 kw-LS, unil. (BP-15862).

■ WKAM Goshen, Ind.—Kosciusko Broadcasting Corp. From 1460 kc, 1 kw-D to 1460 kc, 500 w, 1 kw-LS, DA-N, unil. (BP-15863).

■ WNAG Grenada, Miss.—Grenada Broadcasting Inc. From 1400 kc, 250 w, unil. to 1400 kc, 250 w, 1 kw-LS, unil. (BP-15864).

■ WBGW Bowling Green, Ky.—Bowling Green Broadcasting Co. From 1340 kc, 250 w, unil. to 1340 kc, 250 w, 1 kw-LS, unil. (BP-15865).

■ KTDO Toledo, Ore.—Edward C. McElroy Jr. From 1230 kc, 250 w, unil. to 1230 kc, 250 w, 1 kw-LS, unil. (BP-15866).

■ KTRC Santa Fe, N. M.—Santa Fe Broadcasting Inc. From 1400 kc, 250 w, unil. to 1400 kc, 250 w, 1 kw-LS, unil. (BP-15867).

■ KPRM Park Rapids, Minn.—DeLaHunt Broadcasting Co. From 1240 kc, 100 w, unil. to 1400 kc, 250 w, 1 kw-LS, unil. (BP-15881).

■ WFTL Fort Lauderdale, Fla.—WFTL Broadcasting Co. From 1400 kc, 250 w, unil. to 1400 kc, 250 w, 1 kw-LS, unil. (BP-15882).

■ KLIN Lincoln, Neb.—Fletcher-Mitchell Corp. From 1400 kc, 250 w, unil. to 1400 kc, 250 w, 1 kw-LS, unil. (BP-15883).

■ KMUR Murray, Utah—Oral J. Wilkinson. From 1230 kc, 250 w, unil. to 1230 kc, 250 w, 1 kw-LS, unil. (BP-15885).

■ WSRA Milton, Fla.—Santa Rosa Broadcasting Inc. From 1490 kc, 250 w, unil. to 1490 kc, 250 w, 1 kw-LS, unil. (BP-15890).

■ KVVW Show Low, Ariz.—Peak Broadcasting Co. From 1050 kc, 205 w-D to 970 kc, 1 kw-D (BP-15894).

■ Glennallen, Alaska—Central Alaskan Missions Inc. 790 kc, 5 kw, unil. (BP-15897).

■ KFLW Klamath Falls, Ore.—David F. Snow. From 1450 kc, 250 w, 500 w-LS, unil. to 1450 kc, 250 w, 1 kw-LS, unil. (BP-15901).

■ WSSO Starkville, Miss.—Starkville Broadcasting Co. From 1230 kc, 250 w, unil. to 1230 kc, 250 w, 1 kw-LS, unil. (BP-15902).

■ WHBB Selma, Ala.—Taiton Broadcasting Co. From 1490 kc, 250 w, unil. to 1490 kc, 250 w, 1 kw-LS, unil. (BP-15917).

■ WROX Clarksdale, Miss.—Mrs. Eunice T. Imes. From 1450 kc, 250 w, unil. to 1450 kc, 250 w, 1 kw-LS, unil. (BP-15918).

■ KBYG Big Spring, Tex.—Big Spring Radio Inc. From 1400 kc, 250 w, unil. to 1400 kc, 250 w, 1 kw-LS, unil. (BP-15920).

■ WPIK Alexandria, Va.—Potomac Broadcasting Corp. Change DA system (BMP-10936).

■ WMBM Miami Beach, Fla.—Community Service Broadcasters Inc. From 1490 kc, 250 w, unil. to 1490 kc, 250 w, 1 kw-LS, unil. (BP-15928).

■ WSHB Raeford, N. C.—Stanmar Broadcasting Co. From 1400 kc, 250 w, unil. to 1400 kc, 250 w, 1 kw-LS, unil. (BP-15933).

■ KUNO Corpus Christi, Tex.—KUNO Radio Inc. From 1400 kc, 250 w, unil. to 1400 kc, 250 w, 1 kw-LS, unil. (BP-15937).

■ WKEL Kewanee, Ill.—Kewanee Broadcasting Co. From 1450 kc, 100 w, 500 w-LS, unil. to 1450 kc, 250 w, 500 w-LS, unil. (BP-15941).

■ WJNO West Palm Beach, Fla.—WJNO Radio. From 1230 kc, 250 w, unil. to 1230 kc, 250 w, 1 kw-LS, unil. (BP-15942).

■ WCMC Wildwood, N. J.—Francis J. Matrangola. From 1230 kc, 250 w, unil. to 1230 kc, 250 w, 1 kw-LS, unil. (BP-15945).

■ WELK Charlottesville, Va.—Virginia Broadcasting Co. From 1010 kc, 1 kw-D to 1470 kc, 5 kw, DA-2, unil. (BP-15949).

■ WCWC Ripon, Wis.—Greycote Inc. From 1600 kc, 5 kw-D, DA to 1600 kc, 5 kw, DA-2, unil. (BP-15953).

■ Montpelier, Idaho—Glacius G. Merrill. 1400 kc, 250 w, unil. (BP-15956).

■ WGCD Chester, S. C.—Dispatch Broadcasting Inc. From 1490 kc, 250 w, unil. to 1490 kc, 250 w, 1 kw-LS, unil. (BP-15956).

■ KBZZ La Junta, Colo.—La Junta Broadcasters. From 1400 kc, 250 w, unil. to 1400 kc, 250 w, 1 kw-LS, unil. (BP-15958).

CLASSIFIED ADVERTISEMENTS

(Payable in advance. Checks and money orders only.) (FINAL DEADLINE—Monday preceding publication date.)

- SITUATIONS WANTED 20¢ per word—\$2.00 minimum • HELP WANTED 25¢ per word—\$2.00 minimum.
 - DISPLAY ads \$20.00 per inch—STATIONS FOR SALE, WANTED TO BUY STATIONS and EMPLOYMENT AGENCIES advertising requires display space.
 - All other classifications 30¢ per word—\$4.00 minimum.
 - No charge for blind box number. Send replies to *Broadcasting*, 1735 DeSales St., N.W., Washington, D. C., 20036.
- APPLICANTS: If transcriptions or bulk packages submitted, \$1.00 charge for mailing (Forward remittance separately, please). All transcriptions, photos, etc., sent to box numbers are sent at owner's risk. BROADCASTING expressly repudiates any liability or responsibility for their custody or return.

RADIO

Help Wanted—Management

Management opportunity. Wanted: A sales partner, with experience in sales field proven. Preferably family man. Must have cash to invest. 20% stock available to right party, with possibility of 50%. Station value \$75,000.00 in market of 3 other locals. Located in Utah in 2nd largest metropolitan area, 125,000 population. Box J-3, BROADCASTING.

Wanted manager for aggressive Illinois station with metropolitan service areas population in excess of 200,000. Must be capable of directing sales, news and programing departments and be good at promotion. Well established operation. Middle of the road music, fine news reputation. Salary open. Write Box J-131, BROADCASTING.

Wanted: assistant manager for station in large Illinois city. Should be strong in programing, promotion and news. Salary in accord with ability and experience. Fine opportunity for sharp, competent broadcaster. Write Box J-132, BROADCASTING.

General manager strong in sales. Midwest. Successful record and good references essential. Box J-256, BROADCASTING.

Sales and station manager—West coast near major metropolitan area—1,000 watts full time—opportunity for investment—please write Box J-227, BROADCASTING.

Manager for small market station on west coast. Prefer man with first phone license, experience in sales and programing. Box K-26, BROADCASTING.

Manager and staff wanted for new Xenia, Ohio, am, WGIC, on air soon. Details to Box K-38, BROADCASTING.

Sales

Columbus, Ohio . . . Immediate opening for good salesman, management experience or ready. Top independent. Growing chain, good salary plus. Please write fully. Box G-13, BROADCASTING.

Sales promotion writer, strong on research, sales presentation and ideas in top five market. Box H-128, BROADCASTING.

Sales Manager wanted. Top opportunity in 100,000 market Midwest. Need idea man who is real driver. Must be experienced and have good past record. Write fully. Box J-43, BROADCASTING.

Salesman-announcer; excellent deal for experienced combination salesman-announcer at top-rated modern music station, medium Pennsylvania market. J-330, BROADCASTING.

Opening for experienced sales manager who can sell & direct a sales organization. Must be creative, aggressive, and thoroughly responsible. Salary plus over ride. Pioneer upstate N. Y. station in healthy commercial condition. Send complete resume, photo, and references to Box K-54, BROADCASTING.

Anyone in your family have asthma, arthritis, sinus? Looking for the healthiest driest climate in the world? Aggressive salesman contact KD-HI, Twentynine Palms, Calif.

Help Wanted—(Cont'd)

Sales

California central coast am station needs experienced salesman. State's fastest-growing market. Send resume, photo—KHER, Santa Maria, California.

Experienced salesman for WCLW am and fm. Send replies direct to WCLW. 771 McPherson, Mansfield, Ohio.

WGEE Indianapolis, Indiana. Protected, active account list, salary plus commission, insurance program, retirement plan, opportunity for advancement in 7 station group. Write: Arnold C. Johnson, 4800 E. Raymond St.

Radio salesman. Over \$11,000 per year salary plus commission for men with current billings of at least \$60,000 per year, for local am station. Send complete details to: WJOB, 372 W. Ontario St., Chicago 10, Ill.

The door's open . . . Here's an opportunity for the salesman looking for a chance to grow with a growing organization. If you can sell, follow-up, and become part of the community—Here's the doorway. A talented staff—some of the best announcers and newsmen anywhere! Management one of the nation's most active in broadcast circles. Our town is a quad city area of more than 35,000 located 75 miles from Chicago. Great place to live, great people—this may be your doorway to success. Send photo and resume to Bill Dahisten, WLPO, LaSalle, Illinois.

Sales-announcer. Goin'—Growin'—thrivin' 250 w. daytimer needs a salesman-announcer. One position augments the other, result—\$! Contact: Mr. Walter Olson, Gen. Mgr., Radio Station WLOI-AM, LaPorte, Indiana, 362-6144.

Here's a real opportunity. Single station market with potential unlimited. Will furnish account list of established businesses that will exceed guarantee. Prefer man who can write and announce own commercials. Top flight staff to work with. 15% commission, guarantee, and car allowance. Excellent insurance program, must be married. Live in beautiful vacation land of Wisconsin. No bad habits. Write WOBT, Rheinlander, Wis.

Excellent opportunity at No. 1 5 kw station. Resort town. Combination salesman-announcer. Must have 1st phone ticket. Must have good voice, experienced style. Base salary for announce shift, commission on all sales. Opportunity for advancement in multi-station operation. Prefer college graduate—business administration, but not essential. Send photograph, tape, personal and business references, full background and experience 1st letter. WPCF, Box 1430, Panama City, Fla.

Announcers

Capable deejay newsmen. Illinois adult music kilowatt. Fine opportunity for qualified announcer who can gather, write and deliver news in professional manner, present bright music shows. Excellent pay, many fringe benefits. Send tape, complete resume. Box H-138, BROADCASTING.

Classical music man with solid combo operate-announce commercial experience. Smooth delivery and voice, must be sophisticated in classical music programing. References and resume only. Box J-158, BROADCASTING.

Help Wanted—(Cont'd)

Announcers

Announcer, experienced in play-by-play football for new facility in northern New Hampshire. Send tape, resume, etc. Box J-303, BROADCASTING.

Swinging dee-jay for high-rated number one, top forty station, medium Pennsylvania market; salary open. Box J-329, BROADCASTING.

Experienced staff announcer for good music kilowatt near Chicago. Excellent starting salary, many extra benefits for mature man who can gather, write and deliver news, newsmobile reports, plus bright music shows. Send tape, complete resume, telephone number. Box J-359, BROADCASTING.

Wanted: combo-announcer, first phone needed immediately, 1,000 watt low frequency. Small Virginia town, good signal over 1/2 million people in .05MV coverage. \$100 per week to start. Must have experience. Box J-366, BROADCASTING.

Top rated station in eastern Pennsylvania with heavy accent on news, sports, special events and specialized programming has an immediate opening for topnotch announcer with solid experience authoritative voice and ad lib ability. Excellent salary and talent. Send resume tape and picture to Box K-1, BROADCASTING.

Announcer with news gathering-writing ability wanted for Florida east coast full-timer. Airmail tape, resume, sample news copy and salary requirements. Box K-3, BROADCASTING.

Announcer with versatility who likes small town living and can settle into small market Pennsylvania operation. Married man preferred. Send tape, details of experience, salary requirements. Box K-5, BROADCASTING.

Grand opportunity for experienced morning man to join progressive good music multiple station organization in upper midwest. Immediate opening. Salary open for right man. Send air-check, picture and resume. Box K-8, BROADCASTING.

September opening for staff announcer for upstate New York colleegetown station. dj and news experience a must. Send tape and resume. Box K-11, BROADCASTING.

Announcer, primarily night work. No rockers. Prefer settled family man from midwest. Resume, photograph and tape, first letter. Box K-59, BROADCASTING.

Announcer-salesman. Small Michigan station. Salary plus commission. Excellent income for hard worker. Send tape, resume, references. Box K-62, BROADCASTING.

Need announcer beginning August 25th. \$400.00 per month to start. KBRZ, Freeport, Texas.

Opening for announcer with restricted permit. Non-personality type operation. Good news and commercial delivery required. Want young, single man, KVWM, Showlow, Arizona.

Wichita, Kansas, #1 in market looking for mature jockey with bright, happy sound. Send air check to Rex Hall, P.O.B. 486, KWBB.

Help Wanted—(Cont'd)

Announcers

Florida resort area daytimer needs announcer. Send tape, resume and snapshot. State minimum starting salary. Box J-312, BROADCASTING.

Immediate opening for announcer-newsman. Contact Bill Tedrick, KWRT, Boonville, Mo.

Wanted: Announcer with first class license. Station WAMD, Aberdeen, Md.

3 negro dj's wanted. Must have experience, good references for major market. Contact Program Manager, WHIH, Norfolk, Va., 625-4231, immediately.

WIRL, Peoria, Illinois needs an afternoon drive-time, seasoned, clever personality. Send resume and tape immediately.

WLPM needs an engineer-announcer with 1st class license. No maintenance required. If interested in joining staff of stable, aggressive, well equipped station playing up tempo big band music, send tape picture and resume to: E. D. Beydush, WLPM, Suffolk, Va.

Immediate opening for announcer, experienced announcer desired but will consider broadcast school graduate. Typing ability helpful. Send tape, photo, resume, salary requirements to Art Moran, WMEK, Chase City, Va.

Announcer, 1st phone—5,000 watt midwest independent has immediate opening. Emphasis on air work, little maintenance. Run own board. Send tape, photo, references, complete resume, first letter, WMIX, Mt. Vernon, Illinois.

Annrc-engineer. Some announcing experience and first ticket for station just gone 1000 watts. WNJH, Hammonton, N. J.

First-phone combo announcer for mostly one-man 6-12 p.m. shift, including news, hop & good music. Equal opportunity for qualified. Local am-fm growing operation. No floaters for stable, well paid staff. Send tape, photo & resume. We'll return. WOHI Box 760, East Liverpool, Ohio.

Excellent opportunity at #1 5 kw station. Resort town. Combination salesman-announcer. Must have 1st phone ticket. Must have good voice, experienced style. Base salary for announce shift, commission on all sales. Opportunity for advancement in multi-station operation. Prefer college grad. Business administration but not essential. Send photograph, tape, personal and business references, full background and experience 1st letter. WPCF, Box 1430, Panama City, Florida.

Announcer with 1st class license. Immediate opening. Morning shift. Tightly formatted good music station. Rush resume and tape to Mr. Irv Laing, WQTE, P.O.B. 306, Monroe, Mich.

Young announcer-salesman. Guarantee \$100 weekly to start. WSTV, Stuart, Fla.

Attention combo men: Going regional (d.a.)—need two 1st ticket announcers—start Sept. 15th. Personal audition and interview necessary—reply to Alfred Eyre, Station Manager, WTOR, Torrington, Conn. 06791.

DJ's learn the professional way to introduce a record. 300 interchangeable, intelligent intros by excellent writers for vocals and instrumentals. \$3.95. Broadcast Intros, 975 North 35th, Milwaukee 8, Wisconsin.

Mature voice—Country dj—either rockability or country boy type. Must ad lib copy. Can sell. Must have good appearance. No phone calls. Tapes only to P.O.B. 3623, Little Rock, Ark.

Annrc-newsman, Ability to gather, write, and deliver local news for well equipped station; tape-recorders, beepers, remote link, etc., WNJH, Hammonton, N. J.

Help Wanted—(Cont'd)

Technical

Chief engineer for directional am in major midwest market, who knows all phases of maintenance. Prefer one who is good announcer, and can do some production. Box J-105, BROADCASTING.

South Carolina regional daytimer needs first class engineer for maintenance, plus ability or desire for Combo work. Long established operation with low personnel turnover. Will consider tech school graduates. Salary open depending on experience or qualifications. Send full information in first letter. Any tapes will be returned. Box J-308, BROADCASTING.

Chief engineer for full maintenance and announcing radio. Mississippi. Send tape of voice and qualifications. Box J-320, BROADCASTING.

Engineer wanted for Massachusetts station Box K-6, BROADCASTING.

If you are a hard working, conscientious engineer with first ticket capable of taking full charge of am and fm equipment . . . if you can handle a smooth board . . . if you know good music . . . if you would like to live in one of the finest cities in California . . . you are our man. Send tape and complete resume immediately. Box K-35, BROADCASTING.

Alert, responsible engineer-announcer-citizen. Small market, Kansas am/fm station. Good job. Send complete application. Box K-36, BROADCASTING.

Chief engineer with some announcing duties. An ideal spot for the right man in a good, efficient small market station. Recently moved to new studios and offices, with improved equipment, in a new building. Write KTTN, Trenton, Missouri or call Elmwood 9-2261 for details.

Chief engineer—experienced with directional antenna to supervise construction and become permanent chief engineer of new am station WNDY, Indianapolis, Indiana. Send resume and particulars to Douglas Kahle, Box 491, Pacific Grove, California.

Northern Indiana station wants first class engineer who can announce and handle all maintenance. WRIN, Box 282, Rensselaer, Indiana.

Chief engineer. Am-fm full time operation. Excellent opportunity. WSAM. WSAM FM. Saginaw, Mich.

Radio Transmitter and Receiver Operating and Maintenance Technicians. The United States Information Agency (Voice of America) needs Radio Transmitter and Receiver Operating and Maintenance Technicians for relay stations in Greenville, North Carolina; Marathon, Florida; Dixon and Delano, California; and Bethany, Ohio. These positions for operation and maintenance of high power transmitters and receiver stations require a minimum of five years of responsible technical operating and maintenance experience. Experience at commercial point-to-point communication transmitter stations or as a transmitter development and/or test engineer is also qualifying. Salary determined by applicant's experience and ability. Present rate range is \$6344 to \$10,504 per year; promotional opportunity. Positions are in Career Civil Service, and therefore appointments are made thru competitive examination. Must be American citizen. To apply for this nonwritten examination, please request Announcement No. 283B and application forms from your nearest U. S. Civil Service Commission Representative's Office or write to The Executive Secretary, Board of U. S. Civil Service Examiners, U. S. Information Agency, Washington 25, D. C.

Production—Programing, Others

News editor wanted for Ill. kilowatt metropolitan, strong in news coverage. Progressive, long established station with 3 professional newsmen. Salary excellent, merit raises. Give full details of experience and references in 1st letter to Box J-133, BROADCASTING.

Help Wanted—(Cont'd)

Production—Programing, Others

Have opening for qualified play-by-play sports announcer. Good salary, good work-conditions. Send tape, snapshot and resume. N. C. Station. Box J-309, Broadcasting, or Collect 919-838-3241.

News minded large market midwest, middle of the road indie looking for creative journalist with authoritative voice, good background. Send tape, resume, salary requirements to Box K-39, BROADCASTING.

News and sportscaster as assistant to news director. Will employ young man with little experience if he has good voice and eager to work. Maximum starting salary \$75 a week. Apply H. M. Thauer, WGHQ, Kingston, N. Y.

WIRK, West Palm Beach, has immediate opening for a real pro. Must be strong on production and news. Send tape of dj, news and production, plus resume. Full time. format, pop music operation.

Copywriter-announcer. Emphasis on copy. Ability to meet and greet on and off the air. Middle of the road format. Opportunity for a young man to grow with a 3 station chain. Contact: Mr. Walter Olson, Radio Station WLOI-AM, La Porte, Indiana, 362-6144.

SITUATIONS WANTED

Management

General Manager. Sales background. First phone. 17 years broadcasting. Top references. Box J-163, BROADCASTING.

General/station manager, seeking change for valid reasons. Presently employed as general manager, metropolitan station, 12 years management, sales, promotion, programing, merchandising. Former national sales manager, major market. Desirous of locating medium or small market, with people of integrity. Excellent personal and industry references. Full resume upon request. Box J-311, BROADCASTING.

General/sales manager. 51 years old. 30 years in radio. . . 17 years in management. Immensely capable, experienced, cost conscious, efficient, aggressive, adaptable, diplomatic, competitive, civic-minded and ingenious. Available August 15. Present station being sold. Prefer city 50,000 or more. Write/wire Box J-313, BROADCASTING.

Sales manager; excellent executive, can properly delegate authority, recruit and direct staff, powerful presentations, excellent follow-through, skilful closer. 20 years experience, major market, small market, radio-television. College, family man, clean record. Now employed by property being sold. Box J-323, BROADCASTING.

Young, aggressive, sincere, personable veteran; family; desires position executive assistant to management. Basic responsibilities: public, community relations . . . public affairs . . . publicity . . . promotion . . . research, specialized airwork. Background: extensive, quality, commercial r-tv sportscasting . . . communications masters degree . . . university professor . . . etc . . . pr, news information. Employed, wish to improve position. Top references. J-357, BROADCASTING.

General and/or sales manager, 14 years radio-TV experience. Outstanding sales record. 37 year old family man. Box J-364, BROADCASTING.

Pittsburgh program director strong in promotion, production, news and sales, desires station manager's position in metropolitan market. College graduate, married, 35 years old, references. Box J-367, BROADCASTING.

Situations Wanted—(Cont'd)**Management**

Mr. Station Owner . . . Looking for a heavy-weight? California major market broadcast executive seeking change to medium sized market. In-depth experience in am-fm-tv top management. Very strong on local, regional and national sales plus programming, promotion, etc. Currently vp and manager of broadcasting company. Interested in top management post with possibility of participating in ownership in California am or tv station. Outstanding reputation in industry. 35, family, college graduate. Box K-9, BROADCASTING.

Young husband wife team will manage your station. Twenty years combined experience all phases. First phone, Virginia, two Carolinas preferred. Box K-18, BROADCASTING.

Manager. Experienced. I can solve your problems. Sales, programming, promotions, personnel, public relations. Solid background. Box K-23, BROADCASTING.

Manager 25 years experience all phases, sales, programming, administration, cp's. First class license. Box K-42, BROADCASTING.

Sales

32 family. Radio-television degree August alert 12 years business experience. Need sales-announcing opportunity, possible future management, southwest preferred. Box K-10, BROADCASTING.

Radio Sales-announcer with seven years experience desires job in small market. Married—references. Box K-37, BROADCASTING.

Announcers

First phone announcer, no experience. Want first position. Late 30s. Prefer New York state. Box H-264, BROADCASTING.

First phone personality announcer with 7 years experience, tight board, production conscious. Ready to move up. Want \$160 to start. Box J-117, BROADCASTING.

Announcer with first phone, would like to relocate within 150 to 200 miles of Chicago. Box J-183, BROADCASTING.

Mature, married, announcer desires stable position in western market as dj or pd. Strong on news, 5 years commercial experience. Salary desired \$90-100 per wk. Box J-295, BROADCASTING.

Boston area. Announcer/dj, 27, with first phone seeks part-time work while attending college. Box J-297, BROADCASTING.

Play-by-play experience. High school football, minor league baseball, sales. Out of broadcasting since 1956. Box J-307, BROADCASTING.

Want sports position in radio or tv, experienced in both as announcer, also sales. Excellent play-by-play of all sports. College grad., 27, married. Will relocate for right job. Box J-318, BROADCASTING.

First phone—young announcer, limited experience, 6 to midnight shift only. Box J-346, BROADCASTING.

Ingenious top 40 dj has outgrown medium-large market. Good voice, clever gimmicks, tight airwork and production. 4 years experience. Married and dependable. Box K-7, BROADCASTING.

Experienced announcer seeks staff work with quality station no rock and roll considered. Box K-12, BROADCASTING.

Young announcer, disc-jockey, tight board, first phone—travel anywhere! Box K-15, BROADCASTING.

New England . . . announcer-newscaster two years. Limited college, newspaper, sales. Box K-19, BROADCASTING.

Newsman, announcer, dj, 9 years experience, veteran. Available immediately. Box K-20, BROADCASTING.

Situations Wanted—(Cont'd)**Announcers**

Southwest Nebraska personality-announcer, combo, seeks position nearer twin cities. 21, single. Present employers reference. Box K-24, BROADCASTING.

Young announcer. One year experience. Seeking to relocate. Single, mature voice. Bright personality. Box K-27, BROADCASTING.

1st phone personality—college, draft free, 6 years experience in the top 50 markets. Box K-28, BROADCASTING.

First phone, 2 yrs. experience, college degree, family, no problems, age 24. Personality dj want top 40 with stable organization. Will relocate for right offer. Write Box K-29, BROADCASTING.

Top 40 negro disc-jockey, first phone, will work hard. Box K-30, BROADCASTING.

Experienced adult night people personality, mature voice, tasteful selection of music, dig jazz and entertaining the night people. Box K-40, BROADCASTING.

Currently employed by one of nation's largest metropolitan radio/tv newsrooms, gathering/writing/airing. Also beeps, a.u.v. editing sof. Wish return to variety/entertainment along with news. Am well-paid. Contact only if serious. Box K-44, BROADCASTING.

Thoroughly experienced announcer wants programming, promotion or assistant manager position. Excellent references. Available September 1. Box K-48, BROADCASTING.

Announcer first phone, experienced with network affiliate, tight board, looking for play-by-play opportunity. Box K-50, BROADCASTING.

Looking for play-by-play opportunity. Announcer, first phone, experienced on network affiliate, tight board. Box K-51, BROADCASTING.

Newsman. Announcing school and college graduate, 28. Year experience. First phone, no maintenance. Box K-53, BROADCASTING.

Attention Florida, announcer-1st ticket. Available September. Experienced with CBS affiliate, tight board. Box K-52, BROADCASTING.

7 years experience. Disc jockey, newsman staff announcer. Sensible adult approach. Looking for time slot to conduct good record show. Married, dependable. Former chief announcer in Chicago area. Prefer middle west. Tape, resume available. Box K-55, BROADCASTING.

Negro disc jockey, recent broadcasting school graduate with little experience. Family man with excellent potential. Send for tape and resume. Box K-57, BROADCASTING.

First phone—no broadcast experience—military, commercial experience—willing to learn—age 26—married—prefer west coast. Earl Mahoney, 1830 Utah St., Fairfield, Calif.

Bright announcer/pd. 10 years experience, want to settle in east with growing outfit. Brad Harris 277 Van Siclen Ave., Brooklyn 7, N. Y., Hyacinth 8-5479.

First phone, experience, ambition. Like top forty. Johnny Bowles, P.O. Box 462, Mt. Sterling, Kentucky. Telephone 606-267.

Redbeard seeks rock pd/jock position, 22, married, experienced, ticket. \$500. Terry Randel, Box 1510, Ontario, Calif., phone 714-982-8888.

First phone announcer, young, reliable, available immediately. Prefer southern New England or New York. Ray Kilcoyne, 1101 Dixwell Ave., Hamden, Conn.

Announcer, 9 years, desires late music show. Now employed. Bob Heffner, Route 1, Rockford, Ohio.

Situations Wanted—(Cont'd)**Announcers**

7 years experience—dj announcer, good music man. Mornings or afternoons. Midwest preferred—now employed WPDR, Portage, Wisconsin. Wish to make move. Call Dean Teske, RI 2-2158, or mail address WPDR, ask station mgr. for recommendation. Will send tape.

Attention—West southwest: Swinging dj 9 years experience. Tight board, authoritative news. Ernie Rivera, 413 Don Miguel St., Santa Fe, New Mexico.

Have top 40 disc-jockey ready for immediate employment. Young, extremely eager, and conscientious. Please contact me if interested. Charles F. Walker, Program Manager; Radio Station WKDA, Nashville, Tennessee.

Veteran disc jockey (Cue) 10 years experience. Available now! 174 W. Pine, Mt. Airy, North Carolina.

Northwestern University 1963 graduate in radio-tv film with 6 years commercial announce-production-programing experience in formats from "rock-good music-classics" desires position offering creativity and future in broadcasting, or allied fields. Keep mind—network voice—clean cut appearance. Prefer opportunity utilizing all three in Chicago area. Other locales considered. Resume—prompt reply to all inquiries. Box 136, Bronxville, New York.

Technical

Former engineer in charge all maintenance mega watt uhf transmitter complex, desires new construction and or maintenance position Con. U. S. or overseas. U. S. citizen, presently employed in private industry and holds security clearance. Box J-271, BROADCASTING.

Experienced combination chief engineer, country music only, desires permanent position in south. Excellent character and technical references. Box K-21, BROADCASTING.

First phone, 12 years radio tv receiver repair experience, also 2 way radio maintenance. Available immediately. Box K-46, BROADCASTING.

First phone engineer—three years tv studio, some transmitter experience. Arkansas only. Write or call Herman Campbell, 504-234-6155, 504 E. Vermillion, Lafayette, La.

Experienced engineer radio and tv—first phone—willing to announce. A. J. Baron, 2436 E. 23rd St., Brooklyn 35, N. Y.

1st phone Grantham graduate. Married, technical experience, seeks permanent position southeast U.S.A. Available immediately. Mr. Guy Dempsey, 1326 19th St. N.W., Washington, D. C.

1st phone, 21, sober, reliable, draft exempt, will travel anywhere immediately. Joe Hytovick, 280 Poplar, Dicksoncity, Penna. HUnter 9-0826.

Experienced engineer, announcer. Recently chief 5 kw. Directional. Prefer mountain states region. Joe Lundy, Box 525, Mokane, Missouri.

First phone, beginner, no maintenance experience. Prefer some announcing. Late 30s. Write or call M. Levy, 160 Avenue E., Congress 6-5277, Rochester, N. Y. 14621.

Production—Programing, Others

News—Top delivery, editing, copy, able, experienced and literate. Experienced panel and participation work. Larger market, northeast preferred. Box J-194, BROADCASTING.

Male copywriter. Mature, experienced professional seeking a dominate major-market eastern radio, television station. Box J-229, BROADCASTING.

Due to programming changes, news director, east coast class A market available, September 1st. Box J-288, BROADCASTING.

Situations Wanted—(Cont'd)

Production—Programing, Others

Announcer with personality, producer with ideas and writer that thinks, seeks medium size station to utilize full talent. 4 years AFPS Tokyo, 28, married, 4 children, salary open. Box J-290, BROADCASTING.

Sportscaster: 8 years experience play by play, all major sports. College graduate . . . family man . . . sponsors references. Box J-328, BROADCASTING.

Public affairs—news . . . producer, photographer, writer. 7 yrs. wire-service & news magazine experience, award winning in both. M.A. degree broadcasting & film now final stage. Available September. Box J-332, BROADCASTING.

Experienced sports announcer specializing in play-by-play basketball, please note, will do sports only and will make season commitment only. Will consider any market big or small any locality. Prefer Indiana. Box K-2, BROADCASTING.

Veteran, 25, BA degree, two years play-by-play collegiate football, basketball, hockey, baseball, seeks sports position. Box K-25, BROADCASTING.

Versatile, top-notch, sports play-by-play man with stimulating, accurate, and authoritative presentation. Major college experience in football, basketball, plus all other sports. Available immediately. Excellent references. Box K-32, BROADCASTING.

News director at one of the nation's great small market daytimers desires to move up to metropolitan area. Find it, write it, read it in brisk, authoritative style. 25, married, family, college, radio school grad., vet. Extensive experience all dimensions of reporting including editorials, commentaries, interview, discussions shows, etc. Intelligent, aggressive and thorough newsman looking for progressive, news-minded eastern operation. Box K-33, BROADCASTING.

First class sportscaster looking for permanent position with first class organization. Family. B.A. Box K-41, BROADCASTING.

Experienced newsman wants medium or large market. Family, college, veteran. Box K-56, BROADCASTING.

Two man comedy team! high ratings! sports, sales, copy, too! Box K-58, BROADCASTING.

Needed—a permanent position with established radio-tv operation, preferably in news and sports—over 10 years radio, some tv. Box K-60, BROADCASTING.

Broadcaster skilled radio production, news, sales. AB degree in radio Bob Jones University 1953. Ten years experience all phases local station operation. Married, family, active in church and community affairs. Present position 4½ years. Will join immediately organization with opportunity for advancement. H. Brooks Dawson, 2018 Stevens Ave., Elkhart, Ind.

Experienced radio television newsman gather, write, broadcast local news on camera. Presently employed . . . channel 20 television. Phone 546-5428, Nick Alexander, Springfield, Illinois.

TELEVISION

Help Wanted—Sales

Midwest television station, in two-station market, desires account executive. Minimum three years experience. Excellent salary, plus commission. High earning potential. Top technical and production facilities. This is fast operation. You will be fifth salesman. Answer in detail. Box J-216, BROADCASTING.

Announcers

Southeast network affiliate needs man with experience in public affairs programing and news. Please send resume, picture, references and audio tape to Box K-13, BROADCASTING.

Help Wanted—(Cont'd)

Technical

Top market station looking for negro personnel experienced in programing and engineering departments, both radio and television. College degree desired. 1st class license required for engineering. Box J-203, BROADCASTING.

Chief engineer responsible for technical operation of tv station midwest. Box K-17, BROADCASTING.

Immediate openings for experienced tv engineers in Ampex vtr's, camera, video and maintenance. Please forward resume and references to Mr. Cliff Paul, Tele-Prompter Corporation, Sands Office center, South Memorial Parkway, Huntsville, Alabama.

Very unusual opportunity for several aggressive and qualified electronics men to own and operate franchised branches of our 17-year-old electronics home-study school. Write for free details. CSOE, Box 10634, Jackson 9, Miss.

Production—Programing, Others

Top market station looking for negro personnel experienced in programing and engineering departments, both radio and television. College degree desired. 1st class license required for engineering. Box J-204, BROADCASTING.

Operations manager—for NBC station western Great Lakes medium size market. Must be thoroughly knowledgeable director and preferably with on-camera announcing experience. Strong supervisor. Box J-337, BROADCASTING.

Director—to direct live shows at NBC outlet in medium size market in midwest. Must be thoroughly familiar with commercial staging, lighting preferably with TV announcing background. Box J-338, BROADCASTING.

Children's personality—male or female to fill important supporting role in high rated show. Must be able to perform in two or more of the following categories: Singing, dancing, acting, drawing, character roles, puppets, pantomime, magic. Major eastern TV station offers excellent opportunity to work with outstanding children's personality. Good chance for your own show later. Send complete resume and picture. Box J-360, BROADCASTING.

Major eastern market with heavy live schedule including all major sports needs an outstanding experienced director. Must be capable of doing your own planning, producing, thinking and switching. This is no soft touch but the financial rewards are excellent for man who has much to offer. Interviews will be arranged only on the basis of detailed resume. Box J-361, BROADCASTING.

Southeastern etv has opportunity with challenge for creative producer-director. Must have minimum of two years working experience, college degree preferable, but not required. Send complete resume, photo, and salary requirements to Box K-4, BROADCASTING.

Wanted for one of our large midwest television clients. A top notch experienced television program manager capable of managing production staff, buying film, and also capable of creating programing such as that desired by Minow and Henry and at the same time maintaining top local ratings. This is top position for top man with experience and past successes. Contact Edward Voynow, Edward Petry & Co., 400 North Michigan Ave., Chicago 11, Ill.

Gal copywriter—performer—Seeking top flight tv advertising copywriter with proven ability to do limited performing such as weather, commercials, etc. WSAV-TV, Savannah, Georgia.

News director—Opening for newsman with solid educational and professional background. Must be equally adept in gathering, writing and on-camera performance of news. Only top-flight man will be considered. WSAV-TV, Savannah, Georgia.

TELEVISION

Situations Wanted—Management

I tripled billings in one year. Experienced radio-TV manager with first phone wants challenging opportunity. Box J-345, BROADCASTING.

General-sales manager. Major market experience. 23 years in broadcasting, 13 TV management. Age 43. Box K-16, BROADCASTING.

TV or TV-radio general manager wants new challenge in medium market. Twenty-one years in broadcasting, last 19 same company. Currently managing 1 TV and 2 radio stations for newspaper-owned company. Reliable, dedicated, 38 years old, best references. Personal interview upon request. Box K-45, BROADCASTING.

Sales

Top television salesman now employed wants to relocate as salesman or sales manager. 14 years experience, references, married with family. Box K-63, BROADCASTING.

Announcers

Mature, experienced, employed television announcer-newsman. Desires advancement. Excellent background. Available interview August 25 week. Box K-31, BROADCASTING.

Announcer radio television 9 years, wants television news, sports. Now employed radio. Box K-49, BROADCASTING.

Technical

Permanent transmitter job wanted. Experienced transmitter operation, maintenance, construction and installation. Box J-327, BROADCASTING.

Position of chief or assistant chief of small to medium size station desired. Well qualified. Nine years tv. Best references. Box K-22, BROADCASTING.

Have you opportunity for engineer with 12 years TV experience including color, planning, construction? Last 4 years assistant chief. Box K-34, BROADCASTING.

Television studio technician. Five years experience in all phases of engineering and production using studio and remote facilities. Hold first class phone ticket. Active radio amateur over ten years. Mid-twenties and single. Want position with university having good television facilities and movie division. Objective to obtain engineering degree in these fields. Box K-43, BROADCASTING.

First phone, 12 years radio tv receiver repair experience, also 2 way radio maintenance. Available immediately. Box K-47, BROADCASTING.

Production, Programing & Others

Television sports director available. Complete knowledge of film; authoritative play-by-play; intelligent editorialist. Will create excellent image in sports minded market. Box J-296, BROADCASTING.

Aggressive news director, 13 years radio-tv-newspaper experience. Seeking progressive, news-minded station. Top personality, reporter, writer. Skilled interviewer, editorials, documentaries. College grad. Box J-336, BROADCASTING.

Top notch continuity-traffic director. Eleven years with major southwest outlet. Highly experienced all phases continuity-traffic operation, including copy, logs, avals, etc. Box K-61, BROADCASTING.

WANTED TO BUY

Equipment

Wanted: 150 foot tower console, microphones and other related equipment. Building new station, Box H-149, BROADCASTING.

Raytheon or RCA microwave STL wanted immediately. Box J-202, BROADCASTING or call EN 2-5680, N.Y.C.

Frequency, modulation and phase monitors, Clark 120 or RCA WX2 field strength meter. Console, turntables, limiter etc. State manufacturer, model condition and price. Box J-350, BROADCASTING.

Wanted to buy: Used Gates "yard" console, or equivalent make, in good operating condition, no modifications, also, used console. Chief engineer, KDIA, 327 22nd St., Oakland, Calif.

Automation equipment; recent model only; complete or partial for monaural am; Bill Bigley, KVMA, Magnolia, Arkansas.

Will buy or trade used tape and disc recording equipment—Ampex, Concertone, Magnecord, Presto, etc. Audio equipment for sale Boynton Studio, 10 B Pennsylvania, Tuckahoe, N. Y.

AM frequency and modulation monitors in operational condition. 20 years old maximum. W. S. Cook, 2423 Airport Rd., Colorado Springs, Colorado.

Wanted to buy 220' RG-17U transmission or trade for RG-8U. Write Claude Jones, WRON, Ronceverte, W. Va.

For Sale

Equipment

2 DUMONT TV camera chains—TA 124A complete with viewfinders, cable, etc. Consider all offers. Station Manager, Box 7158, Austin 12, Tex.

Used UHF 1 kw RCA Transmitter excellent condition, immediate delivery, a bargain. WCET, 2222 Chickasaw Street, Cincinnati 19, Ohio.

Xmission Line; Teflon insulated, 1 1/2" rigid, 51.5 Ohm flanged with bullets and all hardware. New—unused. 20 foot length for \$40.00. Quantity discounts. Stock list available. Sierra-Western Electric, 1401 Middle Harbor Road, Oakland 20, California. Telephone 2-3527.

Television/radio transmitters, cameras, microwave, tubes, audio, monitors. Electrofind, 440 Columbus Ave., N.Y.C.

New stock replacement parts for TT-5A transmitter available, also new and used 8D21 tubes, at discounted prices, list available. John Gort, C/E, KDLO-TV, Garden City, South Dakota.

Complete Gates remote control system RDC-10c with frequency and modulation extension meters, all necessary pads for mounting in transmitter of 1000 watts or less, and rack for mounting studio components. Best offer. KVOU, Uvalde, Texas.

Recording/film studio equipment/parts. List, Ken-Del Productions, 515 Shipley, Wilmington, Del.

10 watt, 950.5 mc G.E. model 4BT9A1—includes fm transmitter and receiver with two dishes 1 G.E. 3BT3B—3 sk fm transmitter; also 200 ft. 1 1/2" feed line. Box K-14, BROADCASTING.

Commercial crystals and new or replacement crystals for RCA, Gates, W. E. Bliley and J-K holders, regrinding, repair, etc., BC-604 crystals and Conelrad. Also A. M. monitor service. Nationwide unsolicited testimonials praise our products and fast service. Eidson Electronic Company, Box 96, Temple, Texas.

For Sale

Equipment—(Cont'd)

Thermometer, remote electrical: used by over 100 stations, enables announcer to read the correct outside temperatures from mike position. Installed in less than an hour. Send for brochure. Electra-Temp. Co., Box 111, San Diego 6, Calif.

3/8" Coaxial cable, Andrew Hellax. Black sheath covered. Never used. 85¢ per foot fob El Cajon Electronic Engineering, P. O. Box 012, San Diego 15, California.

For sale type 5A Federal transmitter. Complete multi-channel, radio telephone transmitter designed for general communications use. 5ks of rf carrier power output. May be modulated 100% on frequencies between 2.5 and 15 mc. Five unit design. Approx. 4000 lb. \$3000.00. Dynavac Laboratories, Inc. 7326 Deering St., Canoga Park, Calif.

Complete Gates RCM20 remote system, including meters, shunts, motors. Good condition. \$500. WAAA, Winston-Salem, N. C.

One kw transmitter: Gates BC-1T am broadcast transmitter. Usage on this three year old transmitter, in like-new condition, confined to Conelrad testing. Price of \$3,000.00 includes set of spare tubes and two 640 kc crystals. WBEN, Buffalo 7, N.Y.

Four new RCA 810, three new RCA 813. WVOS, Liberty, N. Y.

Collins ATC cartridge tape machines. Brand new PB-190, \$400.00. Two used but excellent PB-150, \$300.00 each. Roger Miller, 1717 E. 32nd St., Davenport, Iowa, PH 324-3670.

For sale—220' RG-8U transmission—used one year or will trade for RG-17U. Write Claude Jones, WRON, Ronceverte, W. Va.

Western Electric 506-B2 10 kw fm transmitter. Make offer. WHIO-TV, Dayton, Ohio.

Miscellaneous

30,000 Professional Comedy Lines! Topical laugh service featuring deejay comment, introductions. Free catalog. Orben Comedy Books, Atlantic Beach, N. Y.

Jockey Joker is a new series of one line gags for deejays. This publication will be habit forming. First issue \$2.50. Show-Biz Comedy Service (Dept B) 65 Parkway Court, Brooklyn 35, New York.

TV Stations: Tell the importance of television with your own monthly Newsletter. Personalized with your call letters. A great local promotion, low as \$59.50 monthly. Write "TV Reports Newsletter" 1186 Arlington Lane, San Jose 29, California.

Need help? 1000 Super dooper hooper scooper one liners exclusive in your market. Free sample. Lyn Publications, 2221, Steiner St., San Francisco.

We produce commercial saleable radio programs and customized commercials. They are excellent and they are inexpensive. If you have holes in your sound, we'll be happy to offer advice free and results at low cost. Six Twenty Nine Productions, Pensacola, Florida.

Songtime generates enthusiasm! It costs nothing, but gives much. Features the week's religious news, interviews with prominent personalities, top sacred sounds. Songtime . . . America's first religious disc jockey show. Audition tapes available. Write Songtime, Box 116, Boston 20, Mass.

INSTRUCTIONS

FCC first phone license preparation by correspondence or in resident classes. Grantham Schools are located in Los Angeles, Seattle, Kansas City and Washington. For free 44-page brochure write: Dept. 3-K, Grantham Schools, 3123 Gillham Road, Kansas City, Missouri.

INSTRUCTIONS—(Cont'd)

Elkins training now in New Orleans for FCC First Class License in 8 weeks. Nationally known for top quality theory and laboratory instructions. Elkins Radio School, 333 Saint Charles, New Orleans, Louisiana.

Be prepared. First class FCC license in six weeks. Top quality theory and laboratory training. Elkins Radio License School of Atlanta, 1139 Spring St., N.W., Atlanta, Georgia.

FCC first phone license in six weeks. Guaranteed instruction in theory and laboratory methods by master teachers. G. I. approved. Request free brochure. Elkins Radio License School, 2603 Inwood Road, Dallas, Texas.

Elkins Radio License School of Chicago—Six weeks quality instruction in laboratory methods and theory leading to the FCC First Class License. 14 East Jackson St., Chicago 4, Illinois.

Announcing programing, console operation. Twelve weeks intensive, practical training. Finest, most modern equipment available. G. I. approved. Elkins School of Broadcasting, 2603 Inwood Road, Dallas 35, Texas.

Since 1937 Hollywood's oldest school devoted exclusively to Radio and Telecommunications. Graduates on more than 1000 stations. Ratio of jobs to graduates approximately six to one. Day and night classes. Write for 40 page brochure and Graduate placement list. Don Martin School of Radio and Television Arts & Sciences, 1653 North Cherokee, Hollywood, California.

Save time! Save money! You get an FCC first class license in just five (5) weeks with R. E. I. training in beautiful Sarasota. Affiliated with modern, commercial station. Free placement. Radio Engineering Institute of Florida, Inc., 135 Pineapple Ave., P. O. B. 1058, Sarasota, Florida.

San Francisco's Chris Borden School teaches you what you want: 1st phone and "modern" sound. Jobs a plenty. Free placement. Illustrated brochure. 259 Geary Street.

Since 1946. Original course for FCC first phone operator license in six weeks. Over 420 hours instruction and over 200 hours guided discussion at school. Reservations required. Enrolling now for classes starting October 9 and January 8. For information, references and reservations, write William B. Ogden Radio Operational Engineering School, 1150 West Olive Ave., Burbank, California.

Announcing, programing, first phone, all phases electronics. Thorough, intensive practical training. Methods and results proved many times. Free placement service. Allied Technical Schools, 207 Madison, Memphis, Tennessee.

Special accelerated schedule. The Los Angeles Division of Grantham Schools is now offering the proven Grantham first class license course in a special accelerated schedule. Taught by a top notch instructor, this class is "success tested" for the man who must get his first phone in a hurry. For free brochure write: Dept. 3-B Grantham School of Electronics, 1505 N. Western Ave., Los Angeles 27, California.

Jobs waiting for first phone men. Six weeks gets you license in only school with operating 5 kw station. One price includes everything, even room and board. Can be financed. American Academy of Electronics, WLIQ, Sheraton Battle House, Mobile, Alabama.

FCC license in six weeks. Total cost \$285. Our graduates get their licenses and they know electronics. Houston Institute of Electronics, 652 M and M Building, Houston, Texas. CA 7-0529.

Train now in N.Y.C. for FCC first phone license. Proven methods, proven results. Day and evening classes. Placement assistance. Announcer Training Studios, 25 W. 43rd, N. Y. OX 5-9245.

RADIO—HELP WANTED

Production—Programing, Others

NEWSMAN WANTED

50,000 WATT MID-WEST METRO STATION WANTS AGGRESSIVE NEWS-CASTER WITH WRITING AND GATHERING ABILITY. MUST HAVE AUTHORITATIVE VOICE. MINIMUM OF FIVE YEARS EXPERIENCE AND COLLEGE GRADUATE PREFERRED.

SEND AUDITION, SAMPLE OF WRITING, AND SALARY EXPECTED.

BOX K-67, BROADCASTING

Announcers

ALASKA

Bright—Mature voice Good production—fast board Middle-of-road format 6 day, 42 hr. week \$750 mo. AIR-MAIL tape, qualifications references —KHAR, Anchorage.

Network O & O

in major market offers challenge, hard work, little pay, great opportunity to start with new all-talk format. Send resume, tape, to BOX J-220, BROADCASTING.

TELEVISION

HELP WANTED

Technical

TELEVISION CHIEF ENGINEER

Group operation of TV and radio has opening for highly qualified man at major market VHF. Apply in confidence. D. H. Smith, P. O. B. 10, Abany, N. Y.

WANTED TO BUY

Equipment

WILL PAY CASH

FOR REMOTE UNIT COMPLETE OR PRACTICALLY COMPLETE. A SOUND MICROFILM CAMERA COMPLETE WITH ZOOM LENS. 2 MICRO RELAY UNITS COMPLETE. GIVE COMPLETE DESCRIPTION AND PRICE TO GEORGE T. HERNREICH, 601 GARRISON AVENUE, FORT SMITH, AR. KANSAS.

Employment Service

OPPORTUNITY!

ALL BROADCAST PERSONNEL PLACED MOST MAJOR U. S. MARKETS MINOR-MARKET MIDWEST SATURATION WRITE FOR APPLICATION NOW BROADCAST EMPLOYMENT SERVICE

4825 10th Ave. So. Minneapolis, Minn. 55417

For Sale

Equipment

NEED 'EM YESTERDAY?

Get same day shipment on Fidelipac tape cartridges and re-loading service.

GUARANTEED LOWEST PRICES

Try us! Send this coupon with your order now and get postage paid!

SPARTA ELECTRONIC CORPORATION

6450 FREEPORT BOULEVARD
SACRAMENTO 22, CALIFORNIA
GA 1-2070

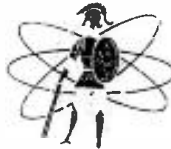

Miscellaneous

Colorful Combination RADIO MARKET SHEETS and COVERAGE MAPS

Address Radio Dept. on your letter-head for FREE information and samples.

EVEREADY ADVERTISING

1817 Broadway • Nashville 4, Tenn.

INSTRUCTIONS

EMERSON COLLEGE

Accredited liberal arts college. Specialization in radio, TV, theatre arts, speech, speech and hearing therapy. B.A., B.S., M.A., M.S. degrees. Day, evening, summer sessions. Broadcasting, announcing, writing, radio and TV production. Electronic production studio, theatre. FM radio station, speech and hearing clinic. Outstanding opportunities for achieving professional competence in acting, directing, and script writing for radio and TV. Coed. 82nd year. For catalog write: Director of Admissions.

EMERSON COLLEGE
303 Berkeley St., Boston 16

RADIO
TV
SPEECH
THEATRE

WANTED TO BUY

Stations

MEDIUM to MEDIUM—LARGE market, good facility, growth potential, preferably North East. To be second station in planned expansion. We're large company with diversified interests, able and ready to buy. Replies confidential. Box K-64, BROADCASTING

Stations

For Sale

Outstanding Opportunity to acquire 13 year old kilowatt day-timer extensively covering booming industrial county. \$85,000, terms Box K-66, BROADCASTING.

CATV System for Sale

All-Band CATV System in Southern city, construction almost completed. Fully organized and staffed, offered for sale.

Brokers Protected
BOX K-65, BROADCASTING

FULL TIME STEREO FM

BROADCASTING STATION 1 Year on the air. Located in West Texas. 1 KW transmitter, effective power 5.3 kw. Desire to sell part or all to qualified operator.

BOX 2442, AMARILLO, TEXAS.

To buy or sell Radio and/or TV properties contact:

PATT McDONALD CO.
P. O. BOX 9266 - GL 3-8080
AUSTIN 56, TEXAS

STATIONS FOR SALE

ROCKY MOUNTAIN. Exclusive. Fulltime. Gross exceeds \$90,000. Priced at \$125,000. 29% down.

NEW ENGLAND. Exclusive. Fulltime. Priced at \$125,000. 29% down.

JACK L. STOLL & ASSOCS.
6381 Hollywood Blvd.
Los Angeles 28, California

Fla.	single	daytime	\$ 70M	terms
N.Y.	single	daytime	125M	36M
Vt.	small	fulltime	100M	29%
Ill.	small	daytime	97M	29%
Ga.	medium	daytime	95M	SOLD
Mass.	medium	regional	185M	29%
Pa.	metro	daytime	155M	25M
S.W.	large	FM	75M	29%

And others.
CHAPMAN COMPANY
2045 Peachtree Rd. N.E., Atlanta 9, Ga



It's a fact...
G. E.'s 7629 and 8092
image orthicons are
highly sensitive,
long-lived tubes...
up to 9000 hours and more...

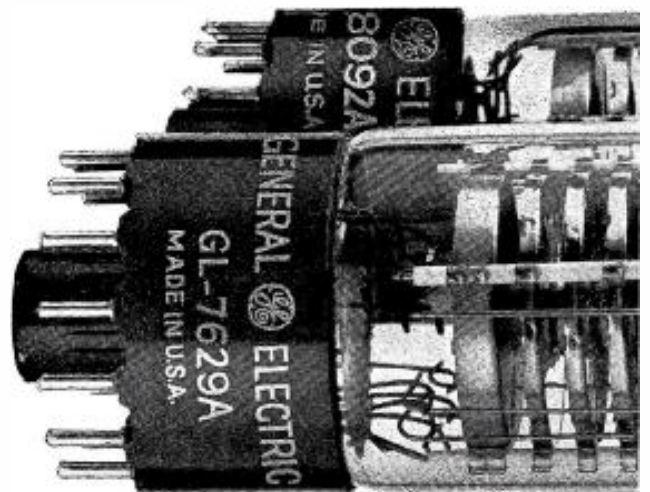
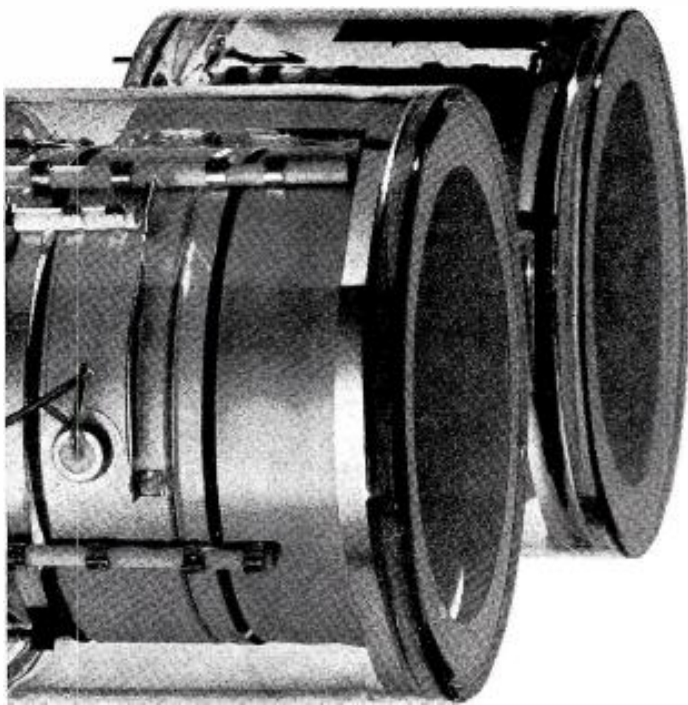

signal-to-noise ratios,
however, were a bit low...

(36:1 and 34:1 average)

Now, in the "A"
versions, we've quieted
them down...

(to 48:1 and 37:1)

HOW? . . . with design improvements utilizing semiconductor target material. G. E.'s new I.O.'s are designated the GL-7629A and GL-8092A . . . why don't you try one in your camera? In fact, try the whole line of newly improved G-E image orthicons: G-E Type GL-5820A, S:N—48:1/GL-7293, S:N—45:1/GL-7629A, S:N—48:1/GL-8092A, S:N—37:1/GL-8093, S:N—55:1. For your **free facts folder**, containing data and application notes on the expanding line of G-E image orthicons and vidicons, write to General Electric Company, Room 8005A, Owensboro, Kentucky, or call your nearest G-E Industrial Tube Distributor, today!

Progress Is Our Most Important Product

GENERAL  ELECTRIC

OUR RESPECTS to Charles Anderson Pratt

An ex-cowboy thrives on wrangling TV's best buys

Charles A. Pratt of Alberto-Culver Co. never needed the help of a \$40 million-plus television advertising budget to be popular.

He's one of those individuals whose personal warmth and business integrity had won a long list of friends years ago when he was still selling TV, not buying it. This was when there were few who could guess that both his career and Alberto-Culver's success would skyrocket to such heights today. Mr. Pratt hasn't changed.

Now vice president-director of advertising and director of public relations for Alberto-Culver, Chuck Pratt joined the company in 1960 after several years with NBC-TV in Chicago as an account executive. He is consistently described by his business associates as one of the most astute and tough, yet fair, negotiators in TV today.

Good Listener ■ Station representatives, network and agency personnel who deal with him regularly find Mr. Pratt's door is always open to any reasonable idea. "But you've really got to do your homework before you call," they agree. All also admire his wit and frankness and respect his drive and enthusiasm.

Starting with the new TV season this fall, Alberto-Culver will spend over \$40 million for TV on an annual basis. Small sums also will go for a careful test of radio and for magazines. Most of the TV money will buy saturation day and night schedules on the three networks but over \$1 million a month will continue to be spent for spot TV. Agencies: Compton, BBDO and J. Walter Thompson, all Chicago.

The new budget is a healthy jump over the \$30 million spent in TV this year and will help push the young Melrose Park, Ill., firm still higher as the biggest TV spender in several product categories in the intensely competitive cosmetic-toiletries and hair product fields. Product diversification also continues, with new entries in the household and food fields due soon.

TV's Very Own ■ This new \$40 million budget is also quite a giant stride beyond the original \$75,000 which President Leonard H. Lavin plunged into TV in Philadelphia in 1955. Mr. Lavin as well as Mr. Pratt believe TV to be the most powerful mass medium today and the catalyst responsible for driving the firm's phenomenal sales records to new plateaus.

Charles Anderson Pratt was born in Chicago on Oct. 17, 1923, and grew up and attended grade school on the city's North Side in the area near the Edge-

water Beach hotel. His father was in the stock and bond business but fiscal figuring had no allure for young Chuck during that period.

His real love was for horses. It first was sparked when he was but age 5 and his father took him riding. The infatuation would never end.

During his secondary school years at Culver Military Academy, Culver, Ind., Chuck was a better-than-average student but horsemanship still ranked as a dominant interest. During the summer when he was 17, Chuck obtained his first job and anyone could guess it right off: professional cowboy.

Back For More ■ He got "40 and found" (\$40 a month and keep) just like all the regular cow hands, he recalls. He worked at the Hereford Ranch near Kremmling, Colo. After his graduation from Culver, Chuck returned to the ranch to work again. He rode horseback into Steamboat Springs to register for the draft in World War II in the early summer of 1942.

But he didn't wait for the draft call to come. He enlisted in the U. S. Cavalry at Fort Riley, Kan., and after his basic training was sent to Fort Bliss, Tex., where the horse soldiers were assigned to Mexican border patrol. Now Corporal Pratt, he next was returned to Fort Riley to instruct cavalry recruits there.

When it became obvious that the cavalry units soon were to be de-horsed

and mechanized, he passed up an opportunity to go to Officer's Training School and requested transfer to the Army with assignment overseas. He got prompt action. Infantry Private Pratt soon was headed for the Pacific.

By the time he was released as a sergeant in October 1945, he had served in New Guinea, the Philippines and the Moluccas. His decorations included the Bronze Star and Purple Heart.

Blind Date ■ In January 1946, Mr. Pratt enrolled as an economics major at Amherst College. He played football one year but he gave that up when troubled by a bit of malaria hangover from the war. One evening in the fall of 1947 he tagged along with a buddy who had a date at nearby Smith College and he was introduced to the girl he would marry the next year. She was Joan Broughton of Dayton, Wash.

They were married June 12, 1948, after her graduation from Smith. Their honeymoon was his summer school session in Maine at Bowdoin College.

The Pratts made their home in Chicago after his graduation from Amherst in January 1949. That year he worked for the *Chicago Tribune's* classified advertising department and the next year he was a local time salesman for WAAF Chicago. In 1951 Mr. Pratt joined the sales staff of WOR-TV New York and later was assigned to the station's Chicago office.

Seller To Buyer ■ Early in 1952 he joined the midwest sales staff of Edward Petry & Co. and stayed there until 1957 when he became account executive for NBC-TV. In early 1960 he was named advertising chief for Alberto-Culver and last month he was promoted to vice president.

The Pratts live in suburban Barrington, Ill., where Mr. Pratt recently was made one of several "mounted deputies" by the local sheriff. Their home is a colonial ranch which fronts on its own lake. The Pratts have three children: Marion 14, Andrew 12 and Charles Jr. 8.

All in the family enjoy their three horses, two Alaskan Malamute sled dogs and a cat. Last summer the dog population was up to 10 but the puppies were sold.

Mr. and Mrs. Pratt share a keen interest in golf too. Mr. Pratt also likes to swim and he is particularly fond of surfing in the ocean.

But after a hard day of work, Mr. Pratt finds nothing is finer than quietly slipping off to the barn to care for the horses. As Mrs. Pratt slyly explains: "He knows they won't talk back."



Mr. Pratt

No doldrums

NOT many years ago, business news tended to dry up in the heat of summer, but the rise of television and the evolution of new patterns of buying have changed all that. Broadcast advertising is becoming more and more a year-round business; even the dog days can produce good news.

Take the last few weeks, for example. The reports on both radio and television business, although not spectacular, have been solidly promising.

An analysis by the Television Bureau of Advertising showed that among the top 100 advertisers, television's share of budget in 1962 rose to almost 58%—and by all current accounts, network and spot TV sales continue to rise. In radio, the networks uniformly have been hailing a business resurgence, while spot salesmen report midsummer sales are beginning to perk and say that, perhaps more significant, agency and advertiser interest is promising.

The outlook, then, appears good for the broadcasting media. If late-summer work matches midsummer prospects, it ought to be a bright autumn.

Time to send in the pros

UNLESS present trends of government control are checked, don't raise your boy to be a broadcast journalist. He faces a career in a play-it-safe, nice-Nellie business that will deal only with issues on which everybody agrees.

Consider, for example, the FCC's July 26 advisory about its fairness doctrine (BROADCASTING, July 29). This statement makes it clear that any broadcast coverage of any issue that is remotely controversial must include or be followed by a presentation of all viewpoints on the subject. To depart from that standard is to invite FCC retribution.

The inevitable consequence of a continued application of the FCC's fairness doctrine will be the avoidance of broadcasts that can lead to disputes. Nothing is more certain to sap the strength of broadcast journalism.

Controversy has always been handled more gingerly by broadcasters than by print journalists, for broadcasters have always been subject to government pressures that print journalists mercifully escape. If those pressures are destined to intensify, broadcast journalism will be diluted in proportion. By comparison, print journalism will become more and more appealing. Adult Americans want something stronger than Pabulum in their diet of news.

Fairness, which is to say comprehensiveness in the presentation of issues about which reasonable people differ, is an admirable objective toward which all responsible journalists in all media strive. It is not, however, a doctrine that can be successfully invoked or enforced by the government. Judgments of fairness will vary as widely as the subjects and situations about which they are made and as widely as the attitudes and biases of the judges. Among journalists themselves there are more apt than not to be variations of opinion about the emphasis to give the parts of any story that entails an exploration of diverging views.

The FCC's decision to release its advisory on fairness has no doubt prompted by the House Communications Subcommittee's hearings on bills to legislate fairness in broadcast editorializing. Plainly the FCC wanted to demonstrate, as it had asserted in its chairman's testimony before the House subcommittee, that it already has the power to make broadcasters be fair.

There is no easy way for broadcasters to counter this trend of increasing government pressure. Yet they must

find ways to arrest it and, hopefully, to turn it around.

Priority, of course, must be given to the presentation of the broadcasting case before the House subcommittee when it resumes its hearings on editorializing later this month. We must hope that broadcasters with experience and competence in editorializing will volunteer to testify.

Beyond that is a longer haul—the counteraction of the FCC's enforcement of its awkward fairness doctrine. This can come about only if broadcast journalists continue to go about their work with such expertness and courage that they can defend it on professional grounds and enlist the support of rival media if the government attempts to move in. Already, despite the natural competition among media, powerful newspapers have taken the broadcasters' side against the proposals for restrictions on editorializing.

Professionalism in broadcast journalism is the only quality that can save the art from the emasculation that some bureaucrats and congressmen have planned for it.

Backsliding

THERE are signs that the National Council of Churches recognizes that it went afield in adopting an ill-conceived, dangerous and wholly unwarranted resolution calling for stricter government controls on television and radio.

The executive director of the NCC has sent a memorandum to all stations attempting to explain the council's pronouncement on the ground that "news accounts" had given an inaccurate picture. (Not the way we read them.) And the executive secretary also has asked for a series of meetings between the council and broadcasters. This comes rather late, since a request for consultation had been made through the National Association of Broadcasters prior to adoption of the resolution but was rejected.

The council has heard from many broadcasters since its pronouncement last month. It doubtlessly has heard also from many of its lay and clergy members too, since, as is pointed out by Carleton D. Brown, WTVL Waterville, Me., only 55 out of a possible 200 members of the general board of the council voted for the resolution, with six against it and no abstentions. Mr. Brown, himself a prominent Protestant layman, vouchsafes that the action does not represent the "majority thinking of the great Protestant churches of the country."

Since to err is human and to forgive divine, we suggest that the council would be well-advised to expunge the resolution from its official records.

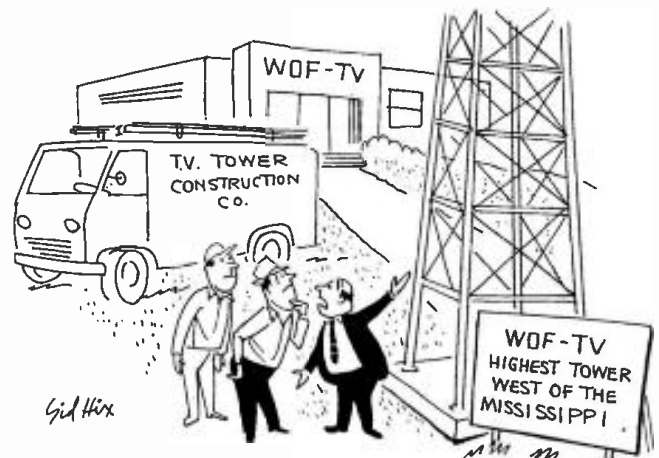

Drawn for BROADCASTING by Sid Hix
 "Could you jack it up a foot or two? Another station just built one a few inches taller!"

Hungry for flavor?

**Kprc-tv's
got it!**



Flavor you never thought you'd get from any Houston TV set!

You'll never know how satisfying Houston television can be until you try KPRC-TV. Fine, flavor—rich showmanship goes into KPRC-TV. Then, the famous channel two

brings out the best taste of the commercials. Sound too good to be true? Buy a pack of KPRC-TV commercials today and see for yourself.

COURTESY OF *The American Tobacco Company*

Channel Two makes the difference



HOUSTON'S *Kprc-tv*

Edward Petry and Company, National Representative

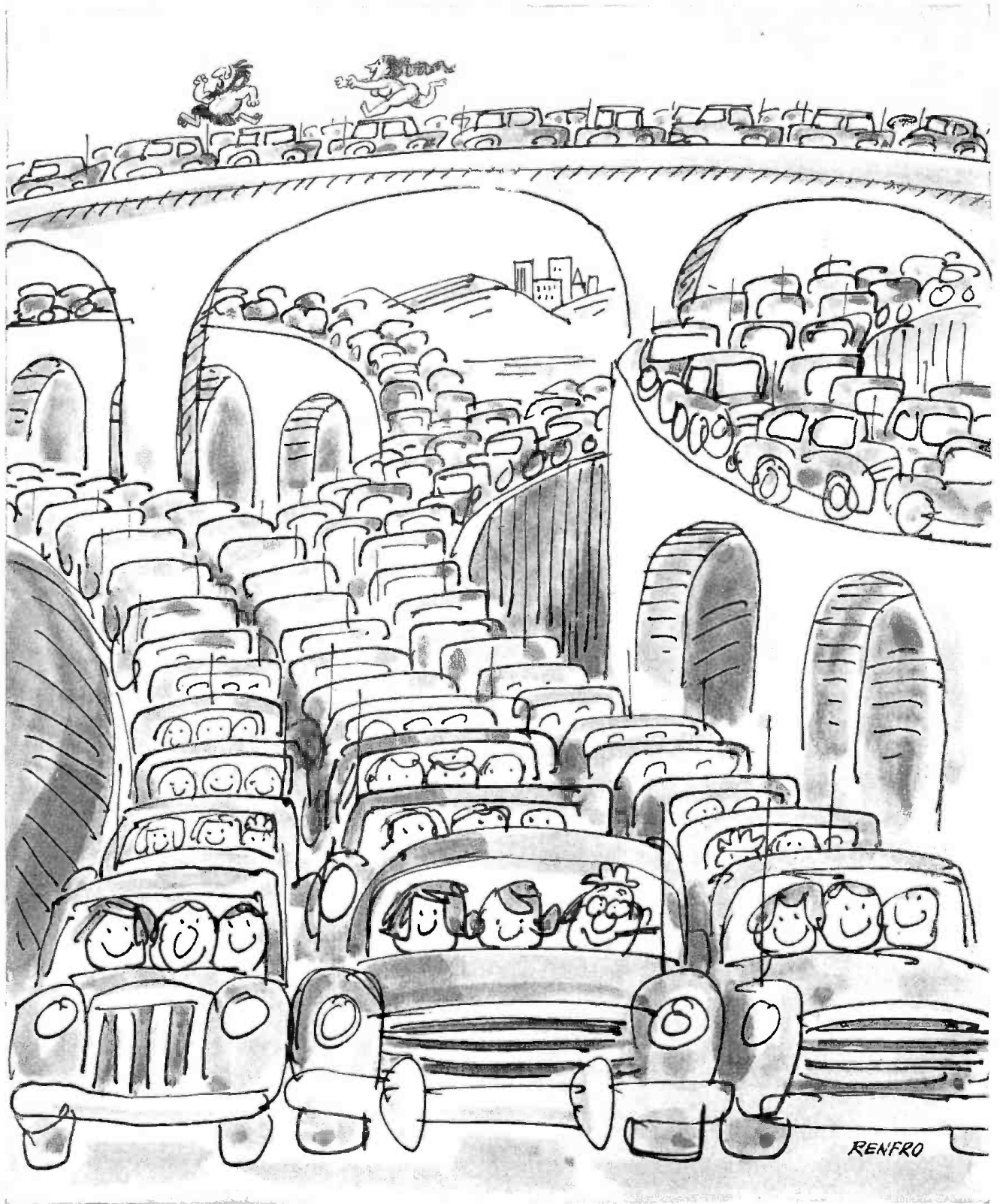

WEEKENDS ARE DIFFERENT... SO IS MONITOR

Families go places together, weekends... Ma, Pa, Sis... and little Sue, just unglued from the funnies. Pa starts the car Ma, the radio. Sis hits back with her transistor. Sue sulks. Pa burns while Ma and Sis fiddle with their sets. "Hey!... Stay there!... That's Mike Nichols"... Sis tunes in, too... harmony... Sue sulks... Elaine May?... Chet Huntley?... Jonathar Winters?... Selma Diamond?... Joseph C. Harsch?... Sports?... David Wayne?... Ethel and Albert?... Travel Tips?... Frank McGee?... something for everyone... specially sponsors! *Can't* be radio!... no, it's **WEEKEND MONITOR**... **NBC RADIO**.