

**knight<sup>®</sup> "600 SERIES" TUBE CHECKER**

A L L I E D R A D I O C H I C A G O

---

## FINAL ASSEMBLY

- 10 lever switch knobs. Push a knob on each shaft of S-4, as shown in Figure 14.
- Large knob. Place on the shaft of S-3, the B-FILAMENT switch. With the switch fully counterclockwise (all the way to the left) tighten the setscrew so the line on the knob points to OFF.
- Large knob. Place on the shaft of R-4, the C-LOAD control. With R-4 fully counterclockwise, tighten the setscrew so the line on the knob points to 0.
- Small knob. Place on the shaft of R-12, the LINE ADJUST control. Tighten the setscrew.
- Small knob. Place on the shaft of S-1, the A-CIRCUIT switch. With S-1 fully counterclockwise, tighten the setscrew so the line on the knob points to 1.
- Install the panel in its case. Fasten with the 10 screws supplied.

## CALIBRATION

**CAUTION: DO NOT TOUCH ANY OF THE WIRING WHILE THIS INSTRUMENT IS PLUGGED INTO A POWER OUTLET.**

- Set your vtvm or any *accurate* AC voltmeter to a scale which has 6.3 AC volts near full scale. Insert the voltmeter leads in pins 2 and 7 of the 8-pin octal socket (socket B on the wiring views).
- Set the tube tester for a 6V6 tube; then turn the tube tester on.
- Set the LINE ADJUST control of the tube tester for a voltmeter reading of exactly 6.3 volts. (Disregard the reading of the Tube Tester meter).
- Adjust R-10, the calibration control mounted on TS-2, until the needle of the Tube Tester meter points exactly to the center. LINE TEST mark.

Calibration is now complete. To maintain calibration, be sure to set the LINE ADJUST control to compensate for fluctuations of line voltage as described in the operating instructions.

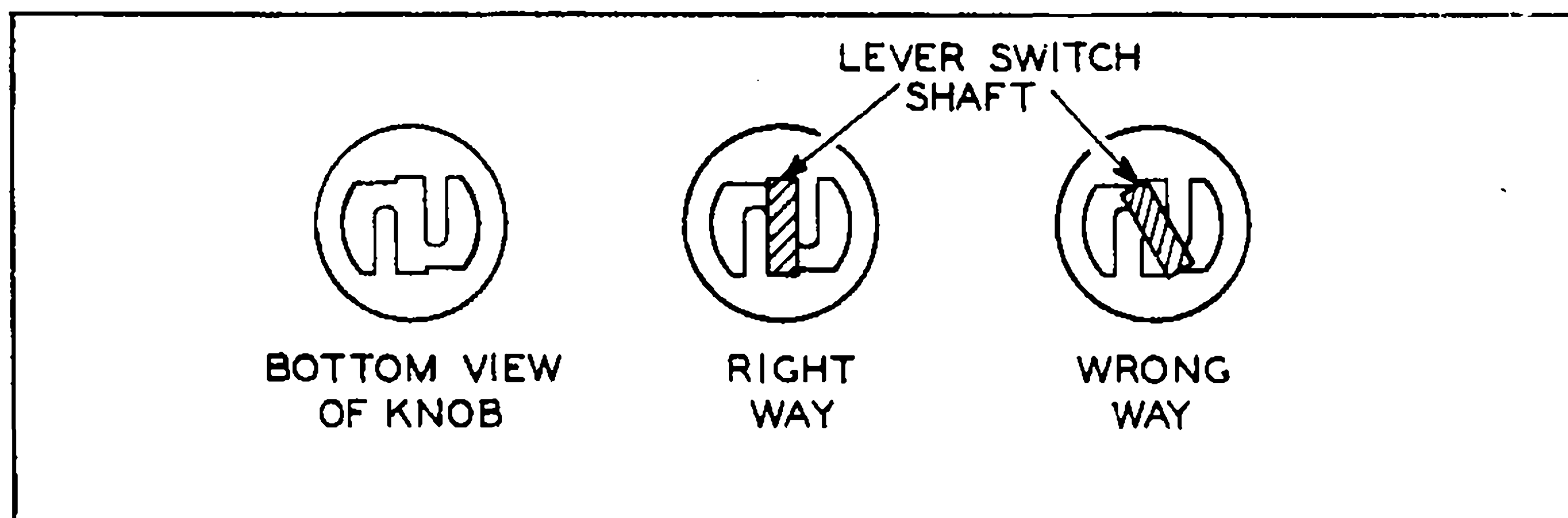

FIGURE 14. HOW TO PUT KNOBS ON THE LEVER SWITCHES

## **SPECIFICATIONS**

### **TUBES TESTED**

4, 5, 6 and 7-pin types, octal, loctal, 7, 9 and 10-pin miniatures, nuvistors, 9-pin novars, 12-pin compactrons, pilot lamps. (CRT adapter available separately)

### **TYPE OF TESTS**

Emission test to show tube condition (green scale on meter, GOOD; red scale, REPLACE)

Check for shorted and open tube elements

Cathode to filament leakage check

Gas Test

Continuity test for any component

### **FILAMENT VOLTAGES**

From 0.63 to 110 volts in 16 steps

### **ROLL CHART**

Illuminated. Lists over 800 tubes

### **INDICATORS**

4½" meter calibrated for tube quality test, gas test and line test

neon bulb for short test

### **CONTROLS**

A-CIRCUIT switch and C-LOAD control. Provide correct sensitivity range

TUBE ELEMENTS switch; selects desired tube element

B FILAMENT switch selects desired filament voltage

LINE ADJUST corrects for line voltage fluctuation

SHORT LINE/VALUE switch selects desired test function

ON/OFF power switch

### **SIZE**

14" wide, 10" deep, 5" high

### **POWER REQUIREMENTS**

105-125 volts, 50-60 cycles AC only

## OPERATING INSTRUCTIONS

- Set all ten lever switches to center position.
  
- Plug the line cord into a 110 volt, 60 cycle AC outlet.
  
- Roll the chart to the tube type to be tested.
  
- Set controls as shown on the roll chart:
  - A-CIRCUIT switch as in column A
  - B-FILAMENT switch as in column B
  - C-LOAD control as in column C
  - TUBE ELEMENTS. Set numbered lever switches listed in column U up, in column D down. For convenience, "0" in these columns stands for lever switch 10.
  
- Insert tube in proper socket.
  
- Turn ON/OFF switch ON.
  
- Set LINE ADJUST so the meter points to the center mark at LINE TEST.
  
- SHORT TEST. Find the lever numbers listed in light-face type in the U and D columns of the roll chart. Place each of these levers in the other two switch positions; then return to the original position. For example, if the lever is UP move it to center, then DOWN and back to up. A shorted tube is indicated by a steady red glow of the SHORT TEST indicator lamp. A faint glow indicates leakage. A brief flash as the switch is moved does not indicate a short.
  
- EMISSION TEST OF TUBE CONDITION. Hold the SHORT LINE/VALUE switch in the VALUE position. Read tube condition (replace or good) on the top scale of the meter. Release the switch.

## OPERATING INSTRUCTIONS (CONTINUED)

- GAS TEST.** Place the lever switch connected to the control grid of the tube in the center position. Press the VALUE switch and read the bottom scale of the meter (good or bad). **CAUTION:** Do not press the VALUE switch for more than 3 or 4 seconds during the gas test. The meter movement may be damaged by excessive deflection.

**NOTE:** If you are not sure which pin is the control grid, look it up in a tube manual. The lever switches are numbered on the front panel to correspond to tube pin numbers, with the following exceptions:

The 12-pin compactron socket, pins 1 and 3 to lever 3; pins 2 and 12 to lever 2; pin 11 to lever 1.

The nuvistor socket, pin 2 to lever 1; pin 4 to lever 2; pin 8 to lever 3; pin 10 to lever 4; pin 12 to lever 5.

### SPECIAL TESTS

#### Open Element Test

- Follow steps 1 through 9.
- Check the U column of the roll chart for numbers in light type face.
- Hold the VALUE switch in its Value position and press the lever switches found in the above step down to D. (Move only one at a time.) Return switch lever to the U position. A change in pointer deflection indicates continuity between the tube pin and the corresponding element being tested. A small change denotes proper plate or screen grid connections, while a large change of deflection indicates a satisfactory control grid connection. For tubes which require only one switch lever in the U position, it will not be necessary to make an open element test.
- Release the VALUE switch.

**Filament and Tap Continuity Test** (Use only if tube type is followed by asterisk(\*))

- Follow Steps 1 through 8.
- Set B-Filament switch to the 0.63 position.
- Check the roll chart in the U-Up and D-Down columns for numbers in dark type face.
- Move each of these switch levers two positions and then return it. A good filament or other internal pin connection is indicated by a glow of the **SHORT TEST** indicator.

#### Continuity Test for Miniature-base Bulbs

- Adjust the B-Filament switch to the voltage of the bulb under the test.
- Place the base of the bulb in the center of the 7-pin socket.
- The normal lighting of the bulb is an indication that it is good.

#### Continuity Test for Ballast Tubes and Electrical Appliances

- Follow Steps 1, 2, 6 and 7.
- Push the bare end of a jumper lead in pin 1 of the 8-pin octal socket. Pin 1 is next to the keyway, on the side of the keyway nearer the meter.
- Turn the B-Filament switch OFF.
- Set switch lever 1 in the U position.
- Set switch lever 10 in the D position.
- Momentarily connect the grid cap lead and the jumper lead together and note that the **SHORT TEST** indicator lights up.
- Connect the grid cap and the jumper lead to the points between which continuity is to be checked. The lighting of the **SHORT TEST** indicator shows continuity between these two points.

**CAUTION:** Do not touch any exposed metal parts of the test leads during the test. If in doubt about the internal connections of the unit which is to be checked, consult the manufacturer's data.

## TUBE CHECK EXAMPLE — 6AG5 TUBE

- Plug the line cord into a 110 volt, 60-cycle AC outlet.
- Adjust the roll chart until the 6AG5 tube information appears in the plastic window.
- Set A-Circuit switch to 3.
- Set B-Filament switch to 6.3.
- Set C-Load control to 20.
- Set lever switch 1 to U.
- Set lever switch 5 to U.  
Set lever switch 6 to U.  
Set lever switch 2 to D.  
Set lever switch 3 to D.  
Set lever switch 7 to D.
- Insert 6AG5 tube in the 7-pin miniature socket.
- Set the LINE ADJUST control so the meter pointer reads at the Line Test mark.
- Short Test. On the roll chart the following numbers appeared in light-face type: 1, 5 and 6. Moving these three levers (one at a time) two positions down and returning them produced no red glow of the Short Test indicator. Therefore, there were no interelement shorts.
- Emission Test. The Value switch was pushed and held to the Value position. The meter read 68 in the green sector of the meter scale. Therefore, the emission was good.
- Release Value switch.
- Reset all lever switches to their normal positions.

## TESTING MULTIPURPOSE TUBES

Many tubes incorporate more than one set of electrodes. These are multipurpose tubes. If such a tube is tested it is necessary to check all sections. Therefore the tube roll chart incorporates certain additions for tubes of this type. Actually, two lines of information are given in one. These are designated "Test 1" and "Test 2."

Dashes are used between the numbers in the columns to separate the information for "Test 1" and "Test 2". The information for "Test 1" is given at the left of the dashes, while the numbers at the right of the dashes concern "Test 2". Note that the B-Fil setting is the same though a tube may have two or more separate tests. If the number of tube sections and tests for one tube exceeds two, a second line is used to give the necessary information.

### **SPECIAL NOTES ON THE ROLL CHART**

For testing certain tube types special notes are given directly below the setup information for the tube. For example, turn the roll chart to the 35B5. Directly under the window appears the note "shows short 1 and 7". This note indicates that a short should be indicated between two elements and between levers "1" and "7". Another note appearing on the roll chart occurs in the case of the 14X7 tube. This note is "Good = 30". This indicates that a meter reading of 30 or higher is satisfactory for this tube.

Sometimes certain tubes have more than one designation. In such cases the preferred type number is given first. This is then followed by the less common type number in parenthesis.

Some tuning indicator tubes are followed by the letters "CL" or "OP". These notations are used in the same manner as "Test 1" and "Test 2" information discussed above. In these cases, no meter indication occurs. The only indication is that the tuning indicator eye is completely closed for the "CL" test and completely open for the "OP" test.

Certain tubes have more than one top cap. A special note will then give the instructions on what should be done for the test. Usually the note will read "short top caps together". This means that a wire jumper should be used to connect the top caps together, and then the grid cap lead is clipped to one of the top caps.

An asterisk (\*) following a tube type indicates that the filament has a tap and the Filament and Continuity Test should be made for this tube.

### **GENERAL NOTES**

If the pointer should run off the scale, the condition of the tube may be extremely good. To make a continuity check on such tubes, the C-Load control should be turned slowly counterclockwise, until the pointer falls below the maximum deflection mark. Then the usual procedure should be followed.

Cathode-to-filament leakage is indicated by a faint glow of the Short Test indicator when the tube checker is set up for a Short Test.

## PARTS LIST

Symbol No.	Description	Part No.
C-1	Capacitor, paper, .1 MFD, 400V.....	245014
R-1	Resistor, 100K ohms, ½ watt.....	301104
R-2	Resistor, 270K ohms, ½ watt.....	301274
R-3	Resistor, 51 ohms, ½ watt, ± 5%.....	302510
R-4	Potentiometer, 200 ohms, wirewound, 2 watt.....	402103
R-5	Resistor, 470 ohms, ½ watt, ± 5%.....	302471
R-6	Resistor, 1500 ohms, ½ watt, ± 5%.....	302152
R-7	Resistor, wirewound, 2500 ohms, 7 watt.....	373006
R-8	Resistor, 5100 ohms, ½ watt, ± 5%.....	302512
R-9	Resistor, 1000 ohms, ½ watt, ± 5%.....	302102
R-10	Control, calibration; 1200 ohms.....	400100
R-11	Resistor, 68K ohms, ½ watt.....	301683
R-12	Control, line adjust; 175 ohms, 25 watt.....	407101
T-1	Transformer, power.....	101307
S-1	Switch, 12-terminal rotary.....	432117
S-2	Switch, 6-terminal, slide.....	431302
S-3	Switch, 17-terminal rotary.....	432125
S-4	Switch, bank of 10 sections.....	434002
S-5	Switch, 2-terminal slide.....	431002
CR-1	Rectifier, meter-type.....	621004
M-1	Meter, 1 ma movement, 4½".....	654207
M-2	Bulb, NE-2 neon.....	640001
M-3,4	Bulb, #44.....	640003

### TUBE SOCKETS

Description	Quantity	Part No.
4-pin, large.....	1	501140
5-pin, large.....	1	501150
5-pin, nuvistor.....	1	501151
6-pin, large.....	1	501160
7-pin large, plus 2 center pins.....	1	501570
7-pin miniature.....	1	501170
8-pin octal.....	1	501182
8-pin loctal.....	1	501181

Description	Quantity	Part No.
9-pin novar.....	1	501192
10-pin miniature.....	1	501100
12-pin compactron.....	1	501101

### MISCELLANEOUS

Bracket, L.....	1	470036
Bracket, roll chart.....	1	470257
Chart, roll.....	1	750224
Clip for M-2 bulb.....	1	492300
Clip, alligator.....	1	532012
Cord, with plug.....	1	802001
Gear, large.....	1	470224
Gear, small.....	2	470226 & 470225
Grommet, rubber; ⅜".....	2	830200
Grommet, rubber; ½".....	2	830002
Insulator.....	1	880004
Knob, ⅜".....	2	761004
Knob, 1⅜".....	2	761304
Knob, lever switch.....	10	764533
Lockring.....	5	532002
Lockring.....	1	532003
List, obsolete tubes.....	1	750068
Manual, instruction.....	1	750132
Nuts, ⅜".....	8	570840
2-56 nut.....	3	570000
Nuts, 4-36.....	9	570230
Nuts, 6-32.....	10	570340
Panel, screened with window.....	1	462251
Rivet, split.....	2	550001
Roller, wood.....	2	850004
Screws, 2-56 x ¼" machine.....	3	560002
Screws, 4-36 x ⅜" machine.....	9	560234
Screws, 6-32 x ¼" machine.....	18	560342
Socket, pilot light.....	2	501724
Solder, 36".....	1	930004
Spacer.....	1	470024
3-terminal strip.....	1	441502
5-terminal strip.....	1	440501
Stud, ⅜" hex nut.....	1	470227

Description	Quantity	Part No.
Tape, 1" gummed paper.....	16"	
Tubing, 5"; plastic.....	2	812004
Washer, ⅜".....	4	582700
Washer, #6.....	5	583300
Wire, 2" red.....	24	801002
Wire, 3" orange.....	30	801003
Wire, 4" yellow.....	17	801004
Wire, 5" green.....	8	801005
Wire, 6" blue.....	5	801006
Wire, 7" violet.....	1	801007
Wire, 8" grey.....	5	801008
Wire, 9" white.....	1	801009
Wire, 10" brown.....	2	801010
Wire, 11" white-brown tracer.....	2	801011
Wire, 12" white-red tracer.....	3	801012
Wire, 6" bare.....	3	806006
Wire, 20" stranded black #20.....	1	804022

### CASE

Case, bench model.....	10	700044
Screws, #4 self-tapping.....	10	569292

### OR

Case, portable.....	1	702001
Wood screws, #6 x ½".....	10	562396

### ACCESSORIES YOU MAY WANT

Stock No.	Description	Price
83 Y 141	TV Picture Tube Adapter for up to 90° Tubes.....	\$4.25
83 Y 271	TV Picture Tube Adapter for 110° Tubes.....	4.25

### TOOLS YOU MAY NEED

46N852	Soldering iron.....	\$5.78
46N521	Soldering iron.....	1.87
50N133	5" Diagonal cutters.....	1.84
50N132	6" Long-nose pliers.....	2.10
45N378	6" Screwdriver.....	.64

\*All Prices Subject to Change



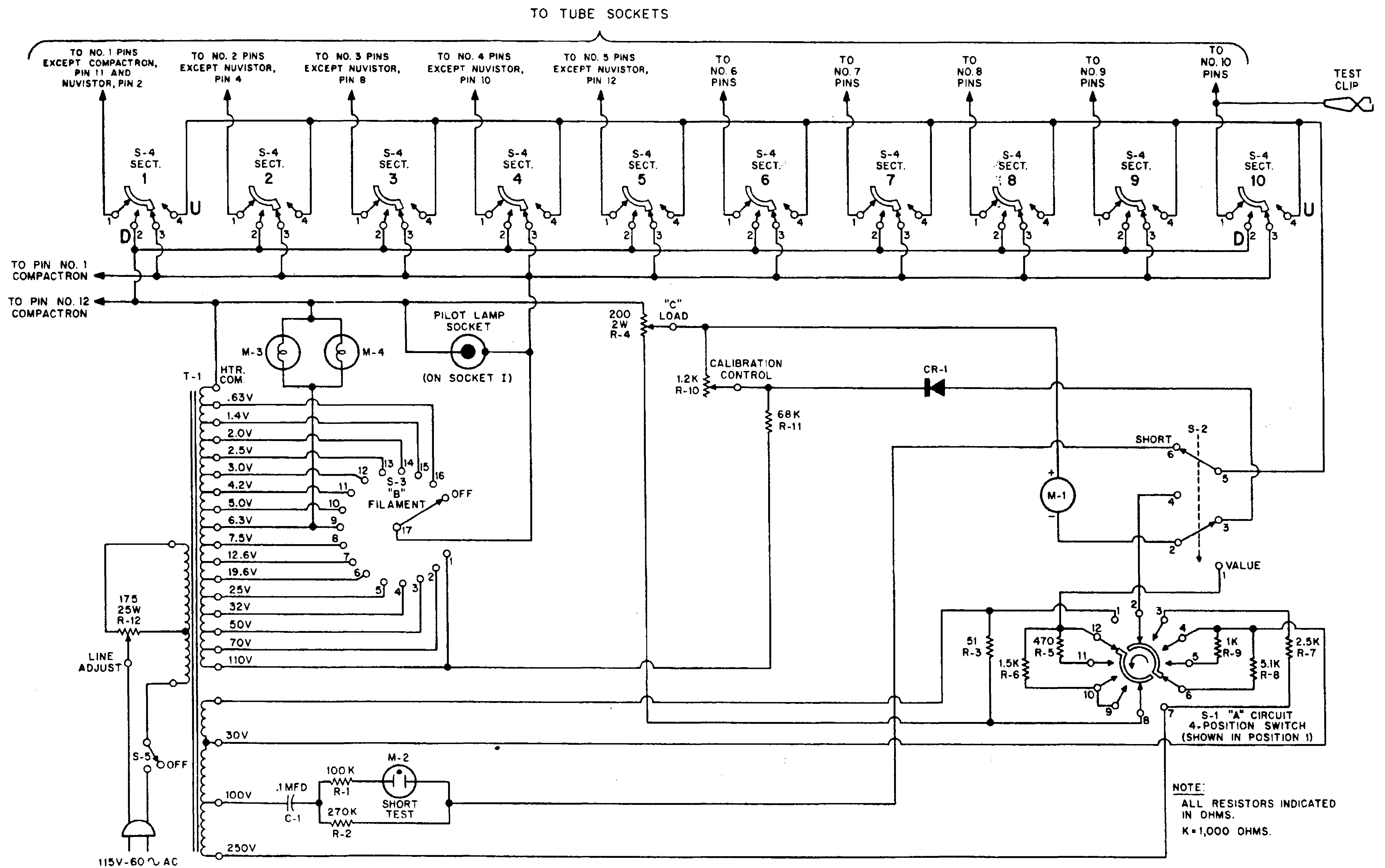

FIGURE 15. SCHEMATIC DIAGRAM