

# The TALKING MACHINE WORLD

For the  
makers &  
sellers of  
talking  
machines

Published Each Month by Estate of Edward Lyman Bill at 373 Fourth Ave., New York, August 15, 1916



## The best-known trade mark in the world

"The Victor talking machine's design, 'His Master's Voice,' has become a household word, and the quaint little fox terrier at attention before the horn is familiar to more Americans than any of the world's great masterpieces"—*Collier's Weekly*.

THE INSTRUMENT OF QUALITY

# Sonora

CLEAR AS A BELL



*Why this is "The Highest Class Talking Machine in the World"*

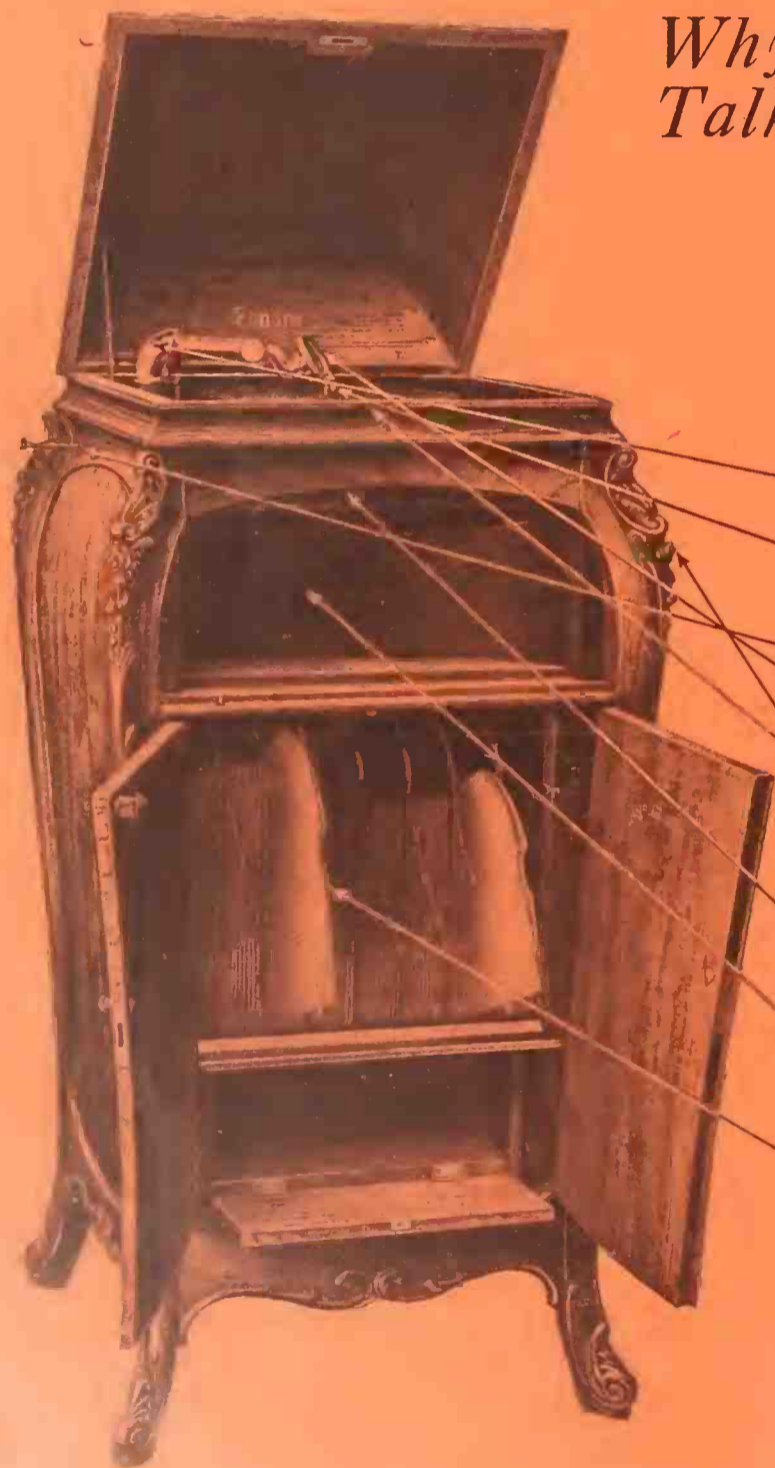

**1—Universal Playing**

THE Sonora is designed to play all makes of disc records perfectly. It was so designed before it was built; no make-shifts or awkward, unsatisfactory devices are added to secure this decided advantage.

**2—Tone Quality**

FOR tone quality the Sonora is without a peer, winning the highest score for this at the Panama-Pacific Exposition in competition with the world's foremost phonographs and talking machines.

**3—Tone Control**

AT the sound source, the proper place, is the Sonora tone control. It is simple in design, but remarkably effective in expression. This is another notable Sonora patent that assists in making this instrument the very best one that human ingenuity has been able to devise.

**4—Sound Box**

THIS assists in reproducing the golden tones and is noteworthy for its excellence of construction. Made from the best of materials, it sends forth notes that are clear, distinct, accurate and beautiful.

**5—Automatic Stop**

ON all machines there is placed an automatic stop, which is decidedly convenient and useful. It is simple and mechanically correct, and gives added pleasure and enjoyment.

**6—Cabinet Work and Design**

THE Sonora is extraordinary for the exceptional beauty of its design and cabinet work. The graceful, flowing lines ("Bulge" effect) are the result of a patented process and are exclusive with Sonora.

**7—Motor**

THE motor is made in Switzerland by experts with generations of experience, and plays about twice as long as do motors of other machines sold at similar prices. For constructional excellence, durability, and strength, it is the supreme motor of the phonograph world.

**8—Sound Amplifier or Horn**

THE sound amplifier helps create the wonderful tone that the Sonora is noted for. It is made on scientific principles and with special treatments that are exclusive with us.

**9—Envelope Filing System**

THIS is a marvel of simplicity and convenience. Records are instantly available and can always be located where and when they are desired.

TEN BEAUTIFUL MODELS

\$45	\$60	\$75	\$100	\$150
\$175	\$190	\$225	\$350	\$1,000

**The Complete Instrument**

THE assembled machine is an aggregation of individually perfect parts correctly combined. As a result, the tone is of unrivaled clarity and magnificence, with a depth of expression that makes the Sonora unqualifiedly "The Highest Class Talking Machine in the World."

*Write today if you are interested in selling this splendid instrument*

## SONORA PHONOGRAPH CORPORATION

GEORGE E. BRIGHTSON, President

Mid-Western Office,  
320 South Wabash Avenue, CHICAGO, ILL.

Main Offices and Salesrooms,  
57 Reade Street, NEW YORK

Western Office,  
344 Geary Street, SAN FRANCISCO, CAL.

*Representatives throughout the country*

# The Talking Machine World

Vol. 12. No. 8

New York, August 15, 1916

Price Twenty Cents

## THE COMPETITION IDEA A BIG FACTOR IN SALES RESULTS

Monthly Sales Contests and Bonus System Prove Good Stimulus to Sales Force in Securing Satisfactory Results—Competition Is the Life of Salesmanship

The spirit of competition goes far to make life worth living. The average man can eat so much, wear only one suit of clothes at a time and otherwise find himself limited in his actual requirements, but in the face of competition he endeavors to eat elaborately in lavish surroundings, have several changes of clothes, all good, and to be seen in fast company, as it were. All this is not just because the individual really wants or enjoys such a condition, but his competitor is doing it, and he endeavors to increase his income to a point where he can show an equal amount of "class." Vanity it may be called, but it is vanity developed through competition, all of which brings us to a discussion of the matter of competition among talking machine salesmen.

There is the natural competition—the desire of every man to get all the business he can and a little more than the other fellow, but many concerns have found it desirable and profitable to stimulate this natural competition by special offers of awards and through contests. Only recently a Western house held a contest among its salesman with a trip to the piano trade conventions in New York as grand prize. Other houses stimulate the competition idea constantly by offering weekly, monthly, or quarterly prizes for the champion salesman. A New Jersey concern keeps the salesmen on edge by running a selling contest each month, the successful man being entitled to a salary increase throughout the month following, the increase continuing until some other salesman captures the monthly prize. With a prize in sight, no matter how inconsequential it may be, every salesman feels stimulated to do his best.

The plain matter of selling, and the steady earning of money are naturally the first inducements, but that soon becomes routine, and all too often the salesman reaches a gait that he maintains without any apparent effort to speed up. It is just such a spirit that affects the athlete, running by himself or with some friends without any real objective. He simply jogs along, covers a certain distance, maybe in good time, but without great enthusiasm. Put the

same man in a race against the field, with a prize offered for the man who breaks the tape, and he puts real effort into his work.

So it is with salesmanship, which is well summed up by a manager who recently said: "Too many talking machine executives labor under the idea that a salesman will not do his best unless he is constantly hounded. In other words, the salesman cannot get through the day and work properly unless he goes out of the store in the morning with a scolding still ringing in his ears. Many managers scold even their best men on every occasion, feeling that if the men realize that the manager is dissatisfied with their efforts they will put forth further energy to suit him. The great trouble with this system is that the ordinary salesman becomes hardened to the continual complaining of the manager, lets the scolding go in one ear and out the other, and plods along in the usual way. On the other hand, the efficient salesman—the valuable man who is doing the best he knows how, producing results—is likely to be of a sensitive nature and allows the constant hounding to get on his nerves. The result is that he either becomes over-wrought and sacrifices much of his ability, or becomes disgusted and goes with a house that treats its men humanely.

"There is no question but that the competition idea is the real secret in inducing salesmen to toe the mark. The 'don't-care' type won't improve under any conditions, but the good man will put forth every effort in his power, not alone for the sake of securing the prize but through the pure love of competition, of doing something and doing it better than his fellows. I, personally, have a monthly contest and give the winning man a bonus of 1 per cent. additional on his actual cash showing, and ½ per cent. on his instalment accounts. It sometimes runs up into money, but the more I pay means the more money I have received. And there are the other dozen or so salesmen who have been bringing in increased business in their efforts to win the prize.

"Competition is the life of trade, and is, therefore, the life of salesmanship."

## THE TALKING MACHINE IN BERMUDA

Victrolas Form Important Part of Stock of E. S. Outerbridge's General Store There

The accompanying photograph shows the store of E. S. Outerbridge, Victor dealer, at



The Store of E. S. Outerbridge St George, Bermuda, with Mr. Outerbridge and H. Royer Smith in the doorway. The photograph was taken during Mr. Smith's recent visit to the island. Mr. Smith is the Illinois wholesale traveler for Lyon & Healy, and he spent a very enjoyable vacation in Bermuda, returning a couple of weeks ago. The Outerbridge store is well known to tourists, as it contains a general assortment of merchandise running all

the way from Victor Victrolas to anchors. Mr. Outerbridge reports a good trade in both machines and records, and says he could do even a larger business than he is doing if he could get a sufficient supply of Victor machines.

## QUITE A SHORTAGE IN WINNIPEG

WINNIPEG, MAN., CAN., August 4.—Robert Shaw is still bemoaning a shortage of Columbia Gramophones. Orders, he states, are piling up, although a plentiful supply of records is arriving in much better shape than formerly. This firm is anticipating good business from its foreign catalog which is being published.

Thos. Nash, manager of His Master's Voice Gramophone Co., Ltd., Toronto, was a recent visitor to the Western Gramophone Co., the Victor distributor for the West. Business is reported good by these firms, in spite of the shortage of Victrolas.

Mr. Fitch, manager of Babson, Bros., Edison phonograph dealers, is back from a six weeks' vacation. This firm has adopted daylight saving upon a majority vote of the employees.

## DISTRIBUTORS FOR THE "VEECO"

The Pathephone Sales Co., 111 East Fourteenth street, New York, has been appointed distributor for the Veeco, the electric motor made by the Victor Electrical Equipment Co., 246 Boylston street, Boston, Mass.

## NEW SONORA SALES MANAGER

Frank J. Coupe, Prominent in the World of Publicity, Also to Assume Post of Advertising Manager—To Co-operate with Dealers

The Sonora Phonograph Corp., 57 Reade street, New York, has secured as its advertising and sales manager, Frank J. Coupe, of the Redfield Advertising Agency, this city. There are few men better known in advertising circles than Frank J. Coupe. For over seventeen years, he has been connected with large corporations, developing sales, advertising, and promotion plans. He is familiar to newspaper and magazine advertising men throughout the country and his knowledge of effective advertising methods is such that aggressive new campaigns may be expected shortly from Sonora headquarters.

Some of the prominent concerns with the business building of which the new Sonora manager has been intimately identified are: Standard Mail Order Co., Kohinor Pencils, Onoto Fountain Pen, American Lead Pencil Co., American Thermos Bottle Co. and many others.

The new connection is not the first association of Mr. Coupe with the Sonora Corp. He has guided its advertising from the days when it was a tiny infant in the phonograph world, until to-day it has grown into one of the big industrial plants of the country.

Because of his wide experience Mr. Coupe will be able to be of particular assistance to the dealers throughout the country in helping them with advertising, selling plans and methods, etc., and he will be in such close touch with them as to act for them as their New York representative. This, in times when the constant cry is, "Send us more machines," is no sinecure.

Though the major part of Mr. Coupe's time will be devoted to the Sonora Corp. he will retain his interest and office as vice-president in the Redfield Advertising Agency, which will continue to handle the Sonora advertising as heretofore.

In a series of letters and booklets which will soon be sent out, the new manager is expected to have something of more than ordinary interest to say to the trade, and as the Sonora way of doing business has always been marked by its independence, originality and sound business sense, the Sonora Corp. and its representatives will without doubt have extra good ammunition for the fall and winter drive this year.

## HANDLE COMPLETE COLUMBIA LINE

WASHINGTON, D. C., August 5.—Lansburg & Bro., of this city, have closed arrangements to handle the complete line of products manufactured by the Columbia Graphophone Co., New York, and have placed a very large initial order with H. C. Grove, manager of the Columbia distributing division in this city.

Lansburg & Bro., who are one of the leading mercantile concerns in Washington, are just completing a seven-story addition to their already large store. With the completion of this addition, they are planning to open several new departments, including one devoted to the Columbia line.

## A. MAGOUN THE NEW MANAGER

A. Magoun, a well-known talking machine man, has been appointed manager of the talking machine department of Otto Wissner, Inc., 53 East Thirty-fourth street, New York, which duties he undertook the first of the month. This house handles the Columbia, Sonora and Victor products. Possessed of a sparkling personality and being well-liked by his customers, Mr. Magoun bids fair to achieve considerable success in his new post of duty.

## INFORMATION OF VALUE TO THE NEW MAN IN THE FIELD

Importance of Having More Than a Cursory Knowledge of the Various Types of Machines and Records—Correct Speed for Reproduction—Some Record Troubles—Some Suggestions

A man going into the talking machine business as a dealer must remember that in entering any new line of business success depends largely upon an understanding of that business. Talking machines do not sell themselves automatically, although the tremendous advertising campaigns carried on in the field almost accomplish that effect. The retailer must know not only how to tell the customer about his machines and records intelligently and authoritatively, but must know enough about the line he handles, or contemplates handling to select stock to the greatest advantage. A little study of the various types of machines and records and the gleanings of some knowledge about the records themselves, should serve to prevent him from investing more or less capital in a line of machines or records that are decidedly foreign to one another, so far as playing qualities are concerned.

With any make of talking machines and records there crop up certain problems that, while simple and readily solved by the man who has been in the trade for some time, cause some trouble to the newcomer. In this section of *The World* information will be given on such problems that do not of necessity concern the technical construction or mechanical features of the instruments which are so capably handled in the department of "Repairs" by A. H. Dodin.

### The Importance of Correct Speed

In the sale of talking machines of any make, it is the demonstration that offers the final argument to the purchaser if the price is right. The machine is sold to reproduce music, and if the reproduction is imperfect and unsatisfactory, fine construction, cabinet attractiveness, strength of spring and all other mechanical details may be set forth for naught.

With the great majority of records a speed of seventy-eight revolutions a minute will be found to give the most satisfactory results. It may be well, if the reproducing speed is not given on the record, for the dealer to write to the manufacturer and learn the speed at which the recording is done, for the recording and reproducing speeds must be the same to give the proper effect and preserve the naturalness of tone. The better class of machines are provided with indicators to show how many revolutions the machine is running. Many machines, however, have simply the speed adjustment without the indicator.

The dealer may learn the proper speed by considerable experimenting, but this does little good to the record and does not impress the

customer very favorably. A better way is when the machines are first received to fix each one at the proper speed so that they will be ready for demonstration at any time. Where there is no indicator, or where the indicator is not accurate, the number of revolutions of the turntable may be readily determined by inserting a strip of paper about one-half inch wide between the record and the turntable, and as the record is played, count the number of times the paper passes a given point within a minute. In making this test, the record should be played in the ordinary manner instead of running free, as it will be found that the weight of the sound box and the pressure of the needle will have some effect upon the speed.

### Making Disc Records at Home

A correspondent has written to inquire if it is possible to make disc records at home. In reply we would say that to the best of our knowledge there is no practical system in vogue for the home recording of disc records. In the first place, the process is somewhat complicated and would require equipment, the cost of which would be prohibitive. In the first place, on the disc talking machines the grooves serve to carry the reproducing point across the record and to record on such a surface it is necessary to provide a mechanism that will carry the recording stylus along at an even speed while the record is being made. Moreover, the material used for most master disc records is so soft, that were it used for ordinary recording a very few reproductions would ruin it.

Our correspondent probably gets his idea from the old cylinder machines, many of which were supplied with record attachments and special records for that purpose. The fact that cylinder machines were equipped with worm gears to carry the recorder along the record surface made this system possible, and are still to be found in connection with various types of dictating machines on the market at the present time.

### Repetition of Certain Notes

A dealer writes to *The World* to inquire why it is that occasionally while playing records the reproduction will be all right through a section of the record and then suddenly one note, or series of notes, will be repeated several times before the reproduction is continued in the proper way. There are several causes for this, the most frequent being some dirt or other foreign substance being in the record groove, which tends to throw the needle back into the preceding groove. The remedy lies in

carefully cleaning out the grooves with a soft brush. Sometimes the repetition is due to the marring of the record through a scratch or indentation by the needle. In such a case, there is no remedy. For ordinary use, constant repetition at that particular point may be avoided, says one who knows, by giving the machine a slight jar when the indentation is reached by the needle, which will cause the needle to jump the obstruction and continue in the groove.

### The Two Types of Records

The frequent reference, in advertisements and elsewhere, to lateral cut and vertical cut or "hill and dale" records, has served to confuse more than one new entrant into the trade ranks and *The World* has, on a number of occasions, been called upon to explain the general difference between the two types of records.

For the benefit of those who are still puzzled, it may be explained that the difference between the lateral cut and the hill and dale records is to be summed up briefly as follows: In the lateral cut records the sound waves are recorded on the walls of the record grooves, the bottom of the groove being smooth. In the hill and dale records the sound waves are recorded at the bottom of the groove, the sides being smooth. In playing lateral cut records the sound box must be kept in a vertical position with the diaphragm parallel with the sound grooves so that the needle follows the sides of the record groove, and the vibrations will be communicated to the diaphragm direct. In playing hill and dale records the reproducer must be placed in position with the diaphragm parallel with the record surface, or upright with the diaphragm surface at right angles with the record grooves so that the vibrations may be carried directly from the sound reproducing surface at the bottom of the record to the diaphragm.

### LEARNING TO BE A SOLDIER

William C. Griffith, with the Chicago Talking Machine Co., Chicago, Ill., has been at the Civilians' Training Camp at Plattsburg, N. Y., learning to be a real soldier. He writes that he has to get up at 5 o'clock on week days, while on Sunday morning he can sleep until 6 o'clock, the extra hour being quite enjoyable, as he puts it. Mr. Griffith is the brother of Tom Griffith, sales manager of the Udell Works, Indianapolis, Ind.

E. H. Gaines, of Gaffney, S. C., is opening a music store in the Wood Building on Frederick street, where he will feature the Edison Diamond Disc phonographs and records. The store will be in charge of Miss Alice Gaines.

# EASTERN VICTOR SERVICE

IS WHAT SUCCESSFUL NEW ENGLAND VICTOR DEALERS USE

*IT HELPS THEM TO BE SUCCESSFUL*

It helps them to attract and hold customers by placing them in a position to give prompt service to their trade, to supply the machine or record wanted, when it is wanted, to make profits.

*IT COSTS NO MORE THAN ORDINARY SERVICE*

## The Eastern Talking Machine Co.

177 TREMONT STREET, BOSTON, MASS.

Largest Exclusive Victor Distributors in the East



**Victrola XI, \$100**  
Mahogany or oak



**Victrola VI, \$25**  
Oak



**Victrola IX, \$50**  
Mahogany or oak



**Victrola XVI, \$200**  
Victrola XVI, electric, \$250  
Mahogany or oak

# Victrola supremacy

Supreme as a musical instrument, the Victrola naturally stands supreme as a business proposition.

The success of Victor dealers follows Victrola supremacy as a matter of course.

**Victor Talking Machine Co., Camden, N. J., U. S. A.**

Berliner Gramophone Co., Montreal, Canadian Distributors.

**Important warning.** Victor Records can be safely and satisfactorily played only with *Victor Needles or Tungs-tone Stylus* on Victors or Victrolas. Victor Records cannot be safely played on machines with jeweled or other reproducing points.



## Victor Distributors

Albany, N. Y..... Gately-Haire Co., Inc.  
 Atlanta, Ga..... Elyea-Austell Co.  
 Phillips & Crew Co.  
 Austin, Tex..... The Talking Machine Co., of  
 Texas.  
 Baltimore, Md..... Cohen & Hughes, Inc.  
 E. F. Droop & Sons Co.  
 H. R. Eisenbrandt Sons, Inc.  
 Bangor, Me..... Andrews Music House Co.  
 Birmingham, Ala... Talking Machine Co.  
 Boston, Mass..... Oliver Ditson Co.  
 The Eastern Talking Machine  
 Co.  
 The M. Steinert & Sons Co.  
 Brooklyn, N. Y..... American Talking Mch. Co.  
 G. T. Williams.  
 Buffalo, N. Y..... W. D. Andrews.  
 Neal, Clark & Neal Co.  
 Burlington, Vt..... American Phonograph Co.  
 Butte, Mont..... Orton Bros.  
 Chicago, Ill..... Lyon & Healy.  
 Chicago Talking Machine Co.  
 The Rudolph Wurlitzer Co.  
 Cincinnati, O..... The Rudolph Wurlitzer Co.  
 Cleveland, O..... The W. H. Buescher & Sons Co.  
 The Collister & Sayle Co.  
 The Eclipse Musical Co.  
 Columbus, O..... The Perry B. Whitsit Co.  
 Dallas, Tex..... Sanger Bros.  
 Denver, Colo..... The Hext Music Co.  
 The Knight-Campbell Music Co.  
 Des Moines, Ia..... Mickel Bros. Co.

Detroit, Mich..... Grinnell Bros.  
 Elmira, N. Y..... Elmira Arms Co.  
 El Paso, Tex..... W. G. Walz Co.  
 Galveston, Tex..... Thos. Goggan & Bro.  
 Honolulu, T. H..... Bergstrom Music Co., Ltd.  
 Indianapolis, Ind... Stewart Talking Machine Co.  
 Jacksonville, Fla... Florida Talking Machine Co.  
 Kansas City, Mo... J. W. Jenkins Sons Music Co.  
 Schmelzer Arms Co.  
 Lincoln, Nebr..... Ross P. Curtice Co.  
 Little Rock, Ark... O. K. Houck Piano Co.  
 Los Angeles, Cal... Sherman, Clay & Co.  
 Memphis, Tenn.... O. K. Houck Piano Co.  
 Milwaukee, Wis.... Badger Talking Machine Co.  
 Minneapolis, Minn.. Beckwith, O'Neill Co.  
 Mobile, Ala..... Wm. H. Reynolds.  
 Montreal, Can..... Berliner Gramophone Co., Ltd.  
 Nashville, Tenn.... O. K. Houck Piano Co.  
 Newark, N. J..... Price Talking Machine Co.  
 New Haven, Conn... Henry Horton.  
 New Orleans, La.... Philip Werlein, Ltd.  
 New York, N. Y.... Blackman Talking Mach. Co.  
 Charles H. Ditson & Co.  
 Landay Bros., Inc.  
 New York Talking Mach. Co.  
 Ormes, Inc.  
 Silas E. Pearsall Co.  
 Emanuel Blout.  
 C. Bruno & Son, Inc.  
 I. Davega, Jr., Inc.  
 S. B. Davega Co.

Omaha, Nebr..... A. Hospe Co.  
 Nebraska Cycle Co.  
 Peoria, Ill..... Putnam-Page Co., Inc.  
 Philadelphia, Pa... Louis Buehn Co., Inc.  
 C. J. Heppe.  
 Penn Phonograph Co., Inc.  
 The Talking Machine Co.  
 H. A. Weymann & Son, Inc.  
 Pittsburgh, Pa..... C. C. Mellor Co., Ltd.  
 Standard Talking Machine Co.  
 W. F. Frederick Piano Co.  
 Portland, Me..... Cressey & Allen, Inc.  
 Portland, Ore..... Sherman, Clay & Co.  
 Providence, R. I... J. Samuels & Bro., Inc.  
 Richmond, Va..... The Corley Co., Inc.  
 W. D. Moses & Co.  
 Rochester, N. Y.... E. J. Chapman.  
 The Talking Machine Co.  
 Salt Lake City, U... Consolidated Music Co.  
 The John Elliott Clark Co.  
 San Antonio, Tex.. Thos. Goggan & Bros.  
 San Francisco, Cal. Sherman, Clay & Co.  
 Seattle, Wash..... Sherman, Clay & Co.  
 Sioux Falls, S. D... Talking Machine Exchange.  
 Spokane, Wash.... Sherman, Clay & Co.  
 St. Louis, Mo..... Koerber-Brenner Music Co.  
 St. Paul, Minn..... W. J. Dyer & Bro.  
 Syracuse, N. Y.... W. D. Andrews Co.  
 Toledo, O..... The Whitney & Currier.  
 Washington, D. C.. Robt. C. Rogers Co.  
 E. F. Droop & Sons Co.

# THE PULLING TEST—THE STRENGTH IS THERE

THE STRONGEST ALBUM MADE AT ANYWHERE NEAR ITS LOW PRICE

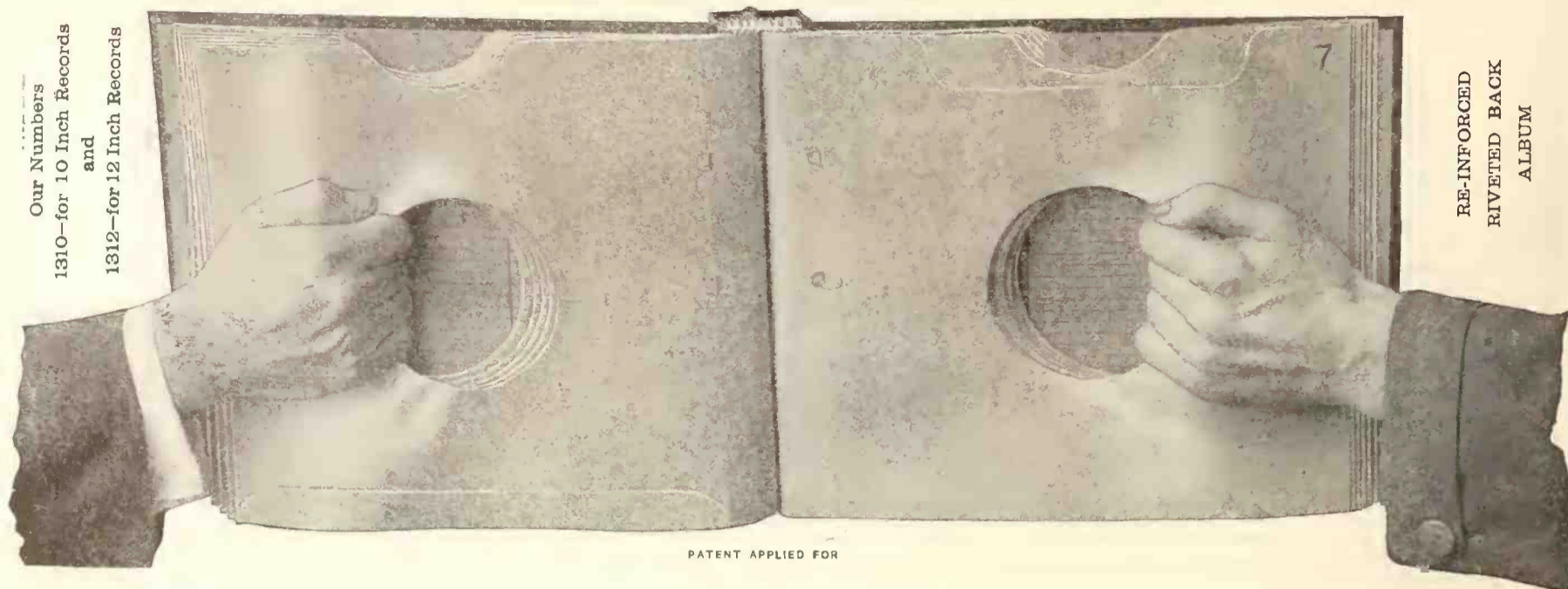

Strength at the Stress and Strain Point. Practically Unbreakable for Regular Usage.

## THE WELL-KNOWN "NATIONAL" RECORD ALBUMS ARE ALWAYS THE LEADERS

### THE ONLY CONVENIENT AND SAFE WAY TO PROTECT DISC RECORDS

These Albums will pay for themselves in a short time by preserving Records. When full the Albums are flat and even like books. They will fit in a library cabinet or book case, or they will lie flat on one another.

We manufacture disc Record Albums containing 12 pockets to fit the Victrola cabinets Nos. X and XI. We also make Albums containing 17 pockets. With the indexes they are a complete system for filing all disc Records.

For durability, finish and artistic design, our Albums have no equal. They are made in the most substantial manner by skilled workmen. We sell our superb Albums at big discounts to meet competition. Shall we quote prices?

THESE ALBUMS ARE THE BEST FOR VICTOR, COLUMBIA AND ALL OTHER DISC RECORDS

NATIONAL PUBLISHING CO., 239 S. AMERICAN ST., PHILADELPHIA, PA.

### TALKERS FOR CANADIAN CAMPS

Heavy Demand for Machines from Vacationists—Higher-Priced Models Have the Call in Montreal—Wm. Lee, Ltd., Opens New Store—New Makes Offered Public—Other News

MONTREAL, CAN., August 4.—The ease with which talking machines may be transferred in automobiles and motor boats, and the pleasant effect of music on the water or in the woods, has made these instruments immensely popular in the summer camp at lake and mountain resorts. From boats out in the lake and from cottages along the shore the music of the best bands, orchestras and singers is being enjoyed by thousands of music lovers who take their machines with them on their trips to the country or to the beach. Dealers within easy automobile distance from resorts and lakes find it profitable to feature talking machines and records and many sales are made to tourists who have high priced instruments at home, but who want smaller and less expensive instruments for their camp or summer home. Such wonderful strides have been made in perfecting low-priced talking machines, it is rare to find a camp of music lovers that does not have one or more of these instruments. They are coming more and more in vogue along the lake

shore for furnishing music to dance with, the marvelous, accurate and clear tone being admired by all.

The Mills Phonograph Co. has removed to 701 St. Lawrence boulevard.

G. M. Reece and Victor Michallis, of the Berliner Gramophone Co., Ltd., were recent visitors to Boston and whilst there called on the Eastern Talking Machine Co., Victor distributors in that city.

The higher priced models of Sonora and Columbia machines are meeting with favor, said Charles Culross, who handles these makes to good advantage. The Sonora Jewel needle is proving exceptionally popular and where one is sold it always means one more to another buyer.

Wm. Lee, Ltd., has opened up at 618-622 St. Catherine street West, and will feature the Edison Amberola, Columbia Grafonola and Stewart machines, besides giving special attention to the repairing of talking machines.

The Rossignol Talking Machine Co., 51 St. Paul street West, has placed on the market a machine wholesaling at \$7.50 upwards.

The remarkable growth of the talking machine department of Layton Bros., Edison and Columbia dealers, has rendered it necessary to remove this department from the second floor to the ground floor. It will be greatly enlarged and

modernized in keeping with the high-class lines handled by this house. Seven soundproof booths each eight by six with a special process of ventilation will be installed.

That the summer camp and summer home business is productive of good business is evidenced by the fact that the Berliner Gramophone Co., Ltd., business in this regard is growing larger every year in the demand for Victor talking machines and records.

### JOINS BOARD OF DIRECTORS

John N. Beach, Prominent in Insurance and Business Circles, Elected Director of the Sonora Phonograph Corp.

At a recent meeting of the board of directors of the Sonora Phonograph Corp. a vacancy was filled by the unanimous election of John N. Beach.

Mr. Beach is very well known in commercial circles, having been actively engaged for many years. At present he is one of the directors of the Equitable Life Assurance Co., and also a director of the Atlantic Mutual Marine Insurance Co., and is president of the Lord's Court Building, 27 Williams street, and is affiliated with numerous other large enterprises. Mr. Beach will form a valuable acquisition to the present board of the Sonora.

### HERRINGTON'S ATTRACTIVE STORE

Norman W. Herrington held a formal opening of his very attractive talking machine store at 1218 Kings Highway, Brooklyn, N. Y., on July 19. The store, which is newly built, is finished in mahogany and white with three sound proof rooms and a floor space 100 feet square, which is used for the display and sale of Sonora phonographs, Columbia Grafonolas and a complete line of records. Mr. Herrington is getting in touch through correspondence with the people of his locality, and so far is doing an excellent business.



## METAL BACK ALBUMS

Give 300% More Service Than Any Other Album

THEY ARE PATENTED

No other Album like it has been or can be manufactured

Send for Sample

NEW YORK ALBUM & CARD CO., 23 Lispenard St., New York



**Victrola IV, \$15**  
Oak



**Victrola VI, \$25**  
Oak



**Victrola VIII, \$40**  
Oak



**Victrola IX, \$50**  
Mahogany or oak

## Victrola supremacy —all the time and everywhere



Viewed from the standpoint of musical art, judged by the character and prestige of the stores that handle it, measured in dollars for its ability as a profit-producer, the Victrola is supreme.

**Victor Talking Machine Co., Camden, N. J., U. S. A.**

Berliner Gramophone Co., Montreal, Canadian Distributors

**Important warning.** Victor Records can be safely and satisfactorily played only with *Victor Needles or Tungs-tone Stylus* on Victors or Victrolas. Victor Records cannot be safely played on machines with jeweled or other reproducing points.

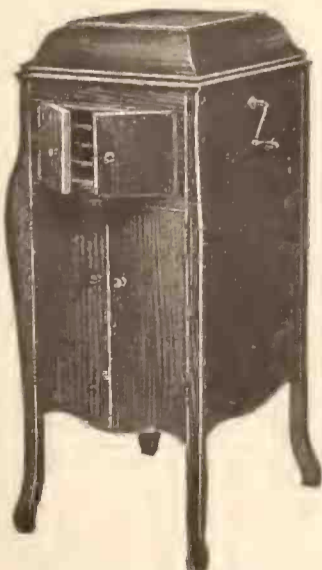

**Victrola X, \$75**  
Mahogany or oak



**Victrola XI, \$100**  
Mahogany or oak

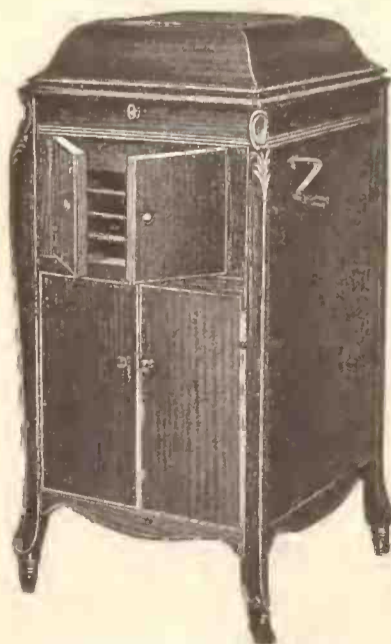

**Victrola XIV, \$150**  
Mahogany or oak



**Victrola XVI, \$200**  
Victrola XVI, electric, \$250  
Mahogany or oak

*The* **TALKING**  
**MACHINE**  
**WORLD**

*For the  
 makers &  
 sellers of  
 talking  
 machines*

**PUBLISHED BY THE ESTATE OF EDWARD LYMAN BILL**  
 (C. L. BILL, Executrix.)

**J. B. SPILLANE, Editor**

**J. RAYMOND BILL, Associate Editor**

**AUGUST J. TIMPE, Business Manager**

**Trade Representatives:** GLAD HENDERSON, C. CHACE, L. E. BOWERS, B. BRITTAIN  
 WILSON, A. J. NICKLIN, L. M. ROBINSON, WILSON D. BUSH, V. D. WALSH

**Boston:** JOHN H. WILSON, 324 Washington Street.

**Chicago Office:** E. P. VAN HARLINGEN, Consumers' Building, 220 South State Street.  
 HENRY S. KINGWILL, Associate. Telephone, Wabash 5774.

**London, Eng., Office:** 2 Gresham Buildings, Basinghall St. W. LIONEL STURDY, Mgr.  
 The Talking Machine World has regular correspondents located in all of the principal cities throughout America.

Published the 15th of every month at 373 Fourth Ave., New York.

**SUBSCRIPTION** (including postage): United States, Mexico, \$1.00 per Year; Canada, \$1.25; all other countries, \$1.75. Single copies, 20 cents.

**ADVERTISEMENTS:** \$4.50 per inch, single column, per insertion. On quarterly or yearly contracts a special discount is allowed. Advertising pages, \$125.00.

**REMITTANCES** should be made payable to the Estate of Edward Lyman Bill by check or Post Office Money Order.

**NOTICE TO ADVERTISERS.**—Advertising copy should reach this office by the first of each month. By following this rule clients will greatly facilitate work at the publication headquarters.

Long Distance Telephones—Numbers 5982-5983 Madison Sq.

Cable Address: "Elbill," New York.

NEW YORK, AUGUST 15, 1916

WHILE it is customary at this season of the year for business men in all lines of trade to slow up in their plans of business promotion, it must be admitted that there has been little of this in evidence in the talking machine trade during the present summer months, for great activity is reported from almost every section of the country. The greater employment of labor and the more general diffusion of money among the people has been prolific of results to the talking machine men.

Relaxation from business pressure is a very necessary requirement during the heated months. It is good for the mind and the body, and every man should have a vacation, but to accomplish this it is not necessary for business houses to shut off steam or permit their business to lay idle.

The modern business organization should be so well arranged that, whether in the wholesale or retail lines, everything progresses during the summer season just as well as the winter season, and it is the man who wisely makes business plans for all seasons who usually wins out.

It will be noted that the business houses who have carried on very active campaigns during the summer months are now being rewarded by increased business. There can be no resting on laurels won in any season, but just the same the plan of operation should call for every member of the force getting an opportunity of resting up and receiving mental and physical rejuvenation so that the entire force is ready for the business activities of the fall season with renewed energy.

AS is universally recognized, the wonderful talking machine business of to-day has been built upon advertising—advertising that has been increased in extent constantly with the passing of years and which was actually increased when those engaged in other lines of business were close to panic and preached retrenchment. In the history of American business there are few, if any, more convincing examples of the power of publicity, carefully thought out and courageously carried out. As the demand for talking machines and records increased and swamped the facilities of the factories, despite frequent large additions to buildings and equipment, the question has frequently been asked "Why increase instead of decrease the advertising when the present demand can only be met in part?" The real explanation of this apparently paradoxical condition was offered by one of the officials of the Victor Co., in an address at the Atlantic City convention when he said: "We are increasing our advertising appropriation by several hundred thousand dollars this year, not

for the present alone, but for the future. The present demand is far in excess of the supply and our advertising is designed to make that condition, so far as possible, a permanent one."

IT is a popular argument adduced by many publishers of books and magazines that the talking machine and automobile have been potent factors in destroying the reading habit among all classes of people. While a casual consideration of these forebodings, corroborated as they are by certain superficial symptoms of a changing public taste, suggests something of credibility in the theory upon which they are based, yet facts are necessarily more convincing than theory. For instance, one New York publishing house announced recently that its bindery has orders now for one million books beyond those it would normally manufacture in the coming three months.

The obvious and important deduction to be made from this convincing evidence of book publishing activity is the very simple one that the public demand for literature produced in comparatively permanent form is increasing rather than abating.

As a matter of fact, the popularity of the talking machine has been a great blessing. It has made a great many people more content with their homes and more inclined to enjoy a good book and at the same time enjoy good music. It has elevated the musical taste of the masses; it has created a desire for better music, and this has created a psychological condition that has also increased the desire for good reading.

This is something rather hard to explain, but the fact remains that anything which inclines to refinement in the home and produces a mental condition that creates a demand for better things, whether it be furnishings or music, also inclines to the demand for good books.

While the popularity of the automobile may be harmful to book publishers, because it takes people away from the home, the talking machine should not be included in this category.

The advertising end of the publishing business should exclude the talking machine when making the argument all too common just now, that there is a decline in the tendency to read good books.

During the last twelve months, evidence is abundant that there is a decided revival of interest in good books, and there is every indication that this interest will grow rather than diminish. It is significant that this increase has gone hand in hand with the increase in the output of talking machines.

THE promises and predictions made by those in charge of the arrangements for the recent annual convention of the National Association of Talking Machine Jobbers regarding the attendance at and profitable character of the sessions at Atlantic City were more than fulfilled at the convention itself. Never before have the jobbers had presented to them so much detailed information regarding the production and selling ends of their business, by those who through close association with the various departments in executive capacities were therefore best qualified to offer authentic information. The problems of manufacturing looked upon by too many of the jobbers as more or less incidental took on a new meaning when explained by those who face the problems constantly. Generous hints on how to advertise most profitably and effectively, how to develop business in the schools, and how to forward the cause of music generally were given to the jobbers in a form that made them usable and understandable. All this was topped off by a tour of inspection of the great Victor plant, and much of the work previously explained by department heads was actually witnessed.

Although the usual attractive entertainments at Atlantic City and Philadelphia were enjoyed to the utmost, the conventionists for the most part attended the meetings with deep appreciation of the importance attached thereto, and carried away with them a fund of new ideas that should manifest itself in a more than normal increase of business during the coming year.

The convention went far to prove that the talking machine industry is not built on the hit or miss plan. It has its manufacturing and sales problems and a future to be protected just as any other business and the wonderful success that has come to those who have stuck to the business during the past years has not been the result of sheer luck, but rather the result of intelligent and expensive exploitation work carried on by those ranking



as pioneers in the trade, and is indicative of a spirit of confidence in the future of the business that has seldom been seen.

Those who for any reason were unable to be present at the Atlantic City meetings will do well to re-read and study the complete reports of the sessions published in *The World* last month. Therein is to be found material that will prove highly valuable in developing business in the months to come.

A TALKING machine dealer, located in a Western city, who has won quite a reputation as a salesman as well as an executive, was a visitor to the sanctum of *The World* the other day, and when cross-examined as to what peculiar talents or gifts he possesses that enable him to score such a special success in his field, he stated that there was nothing remarkable about his accomplishments other than the fact that he had made it an object, whenever he had a holiday, of seeking trade information, of broadening his knowledge of men and things.

In quite a friendly way he would call upon local retailers, sometimes as a customer, sometimes as a visitor. He would note how he was received, how the salesman "talked up" the lines about which he inquired, and how his demands in general were met. He thus acquired much valuable information which he utilized when he got back to his own warerooms. His experiences were many and varied, and some of them induced him to modify his own methods very considerably; for he remarked that to stand in the warerooms of another man was like seeing himself as others saw him, and he never failed to profit by the lesson.

There is a moral here which is so transparent that there is hardly need for elucidation—it means that the merchant or salesman who desires to become an adept at his business must not be content with his own theory of doing things, but rather find out by practical example whether someone else is not doing things better.

No man has yet been able to know everything, and the egotistic salesman who thinks that his sales methods cannot be excelled is rather a dangerous personality in any business, for he never seeks to learn. What a contrast is to be found in the man who realizes that he knows his business pretty thoroughly, but who always seeks for suggestions and who never fails to adopt a better plan of doing things when he learns of them.

It is hardly necessary to say that the Western merchant above referred to has built up a very fine business, and, as might be expected, he is affiliated with lines of national reputation, the sales of which add to his standing in the community.

THIS is an age of ideas. Never before in the history of the world has there been such an urgent and increasing demand for bright thoughts of a commercial nature.

The competition which yearly draws the lines of trade tighter, and sifts men and affairs with a relentless force, turns

the business mind upon some new object with which to strike out from the crowded highway into an unbeaten path toward success.

In every office, store and shop throughout the wide world there is somebody who is continually thinking and seeking for an idea which will help his affairs. The clergyman is thinking of an idea which will extend his influence. The physician, as he sits by the bedside, is seeking for some new idea which will aid nature. The banker is puzzling his brain for an idea which will master finance, and talking machine manufacturers, jobbers and dealers are on the still hunt for ideas to improve their business. It only requires a mere idea, if it is a perfect one, to prepare the foundation for a great success; but, like inventions, ideas which stand the test of practice are rare indeed.

Men who have that peculiar faculty which enables them to so apply old principles to new purposes as to produce a novel idea or method are the sort of inventors whom the world admires and rewards.

It is said that ninety out of every one hundred business men fail who continue in a given line for a term of years, and the majority of those who do succeed will tell you that a new idea which turned the current of their thoughts was the keystone of their prosperity.

IN no branch of the music trade industry is more attention being given to the value of window display than in the talking machine trade. As a matter of fact the window as a sales factor is a topic that is of continuous interest and one which is engaging the attention of the best minds in all lines of industry to-day. While it is only one of a number of factors that contribute to a store's success, yet it is a vital one, because the window is a continuous trade promoter day and night, and where the merchant gives it intelligent attention, it is bound to be a profit-maker. As someone said recently: Don't be afraid to be seen looking straight into your competitor's window and look deliberately, too, for you may there and then discover the real reason for his success, for in these days an attractively arranged window is almost too big an asset to set a limit upon.

When you see a whole front torn out of a comparatively new building, just to put in a new idea of a window, just make up your mind that that merchant is a smart one, and has discovered the value of a good looking window, and he doesn't care what he spends to build and dress it.

It will pay to make your windows look smart at any cost. Make people think they want what they never thought they wanted before, and they will want when they see attractive looking windows. Now, if you have well digested this fact, and put it into execution, you have conquered a big obstacle to success.

You should put your personality into your show windows, displays and your store, and make them represent you by having everything therein look neat, attractive and dignified.

# DITSON VICTOR SERVICE

For many years we have helped dealers to grow, not only dealers in Victor talking machines, records and supplies, but also dealers in Musical Merchandise and Sheet Music.

This experience is at your service and it is the kind that has been developed by actual service on the firing line.

So when you use Ditson Service, you secure the best. Let us talk over a "Fall Campaign" with you.

Oliver Ditson Company  
**BOSTON**

Chas. H. Ditson & Co.  
**NEW YORK**



The Otto Heineman Phonograph Supply Co.

INCORPORATED

25 WEST 45th STREET, NEW YORK

FACTORY, ELYRIA, OHIO



ANNOUNCES THE

# Heineman Motor No. 3

1917 MODEL

**Standard Motor for Floor Machines**

**Now Ready for Delivery**

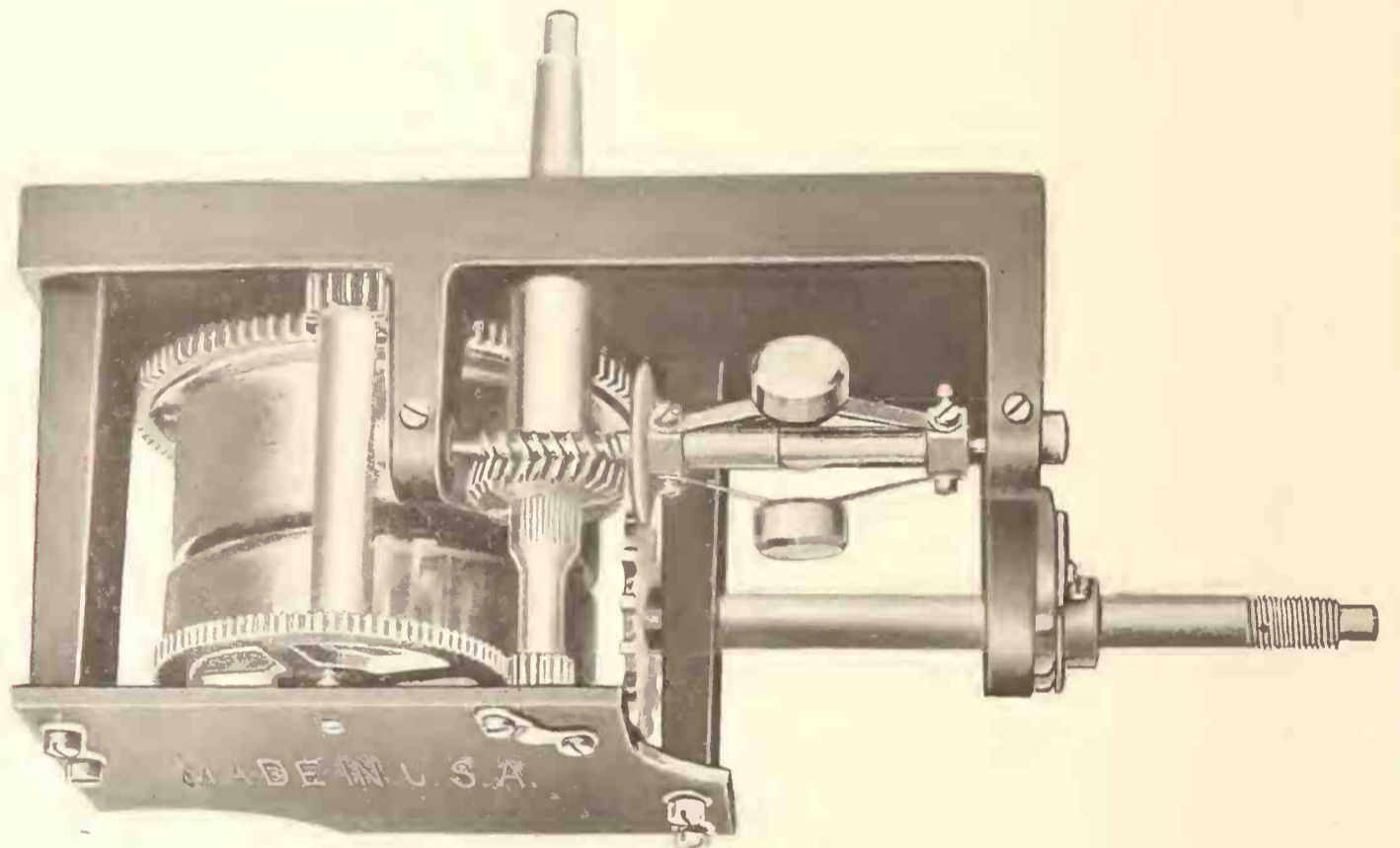

Two-Thirds Size of Motor

## Some of its New Features

1. All bearings are hardened, burnished and polished.
2. Governor is fitted with thrust bearings.
3. Turntable shaft on end, burnished, polished and hardened.
4. Turntable with cast iron bushing riveted on.
5. Frame and spring barrels high grade japanned enamel, absolutely rust proof.
6. Lock washers under every screw.



*Otto Heineman*  
President



**The instrumental line of Columbia Double-Disc Records gains a marked increase in strength through the announcement of the first recordings by De Pachmann, master pianist. First recordings in the September Columbia list—out August 20th.**

(Write for "Music Money," a book "full of meat" for those dealers interested in quick and frequent turnover of capital.)

**Columbia Graphophone Co.  
Woolworth Building, New York**



## BIG PERCENTAGE OF INCREASE IN PACIFIC COAST TRADE

Excellent Reports Made for First Half of Current Year—Labor Troubles Tie Up Shipping—New Sonora "Supreme" Model Displayed—Talking Machine Men Now on Vacation Bent—Remodeling Recital Hall of Edison Shop—Changes Among Sales Staffs—Other News

SAN FRANCISCO, CAL., August 1.—The first half year reports in the San Francisco talking machine business show a considerable increase over the same period a year ago. Some firms report business over the entire Coast territory to be as heavy for the first half of the year as for the entire year of 1915, but on the whole it is perhaps unsafe to claim there has been more than a 25 per cent. increase. The greatly increased demand for records has helped most to swell the volume, and, of course, the number of cheap new machines on the market is largely responsible for the unusually heavy record sales. The summer months are not much brisker than normal in most of the local talking machine departments, but spring business was very good. Labor trouble in the shipping trades has interfered with business a great deal since the first of June and the trouble is not over yet, though the situation has eased up a great deal in the past two weeks. There was some car shortage due to the tying up of water shipping, but the talking machine trade has not suffered unduly. Leading concerns are still hampered by their inability to get sufficient supplies from the factories. This is vacation season and many dealers are away to the mountains or other summer retreats. Talking machines seem to be more popular for dancing at the summer resorts this year than ever before.

### Displaying the Sonora "Supreme"

The San Francisco branch of the Sonora Phonograph Corp. has now on display one of the magnificent thousand-dollar phonographs, the "Supreme," at its Geary street sales rooms and it is attracting a lot of attention. F. B. Travers, manager of the company, has been spending a very pleasant vacation in the High Sierras this month.

### A. R. Pommer an Enthusiastic Golfer

A. R. Pommer, head of the Pacific Phonograph Co., attended the national golf tournament at Del Monte, Cal., this month. His enthusiasm for the ancient and royal game is just as keen as ever.

O. N. Kruschke, sales manager of the Pacific Phonograph Co., is at present calling on the trade up the Sacramento Valley.

The Pacific Phonograph Co. reports business up to July first to be greater than for the whole of last year, with the best half of the year yet to come. The record business has been exceptionally good, but the sale of machines outstripped all expectations. The average price of the machines sold came to over \$125.

### Mrs. Edwards Back to Edison Shop

Josephine Edwards, who has been with the Pacific Phonograph Co., is now back on the floor of the Edison Shop. "It seems like home to be back here," she remarked, "and it is most pleasing to know that the old customers have not forgotten me." Mrs. Edwards has had a

wide experience with Edison phonographs, having been with the Edison Shop previously and on the traveling sales force of the Pacific Phonograph Co. Last year she was in charge of the Edison recital work at the Panama-Pacific Exposition, playing the Edison diamond disc with the Kimball pipe organ. Here she attained considerable distinction by the high order of the entertainment she provided and won recognition as one of the ablest women in the talking machine field of the Pacific Coast.

Mrs. Norris, who was very popular as a demonstrator of the Edison phonograph, is no longer in charge of the recitals at the Edison Shop. In fact, the voice and phonograph recitals have been discontinued for the summer, though the weekly Saturday record recital is still given. Mrs. Norris is at present at Fresno.

### Remodeling Recital Hall

The recital hall on the mezzanine floor of the Edison Shop is undergoing a radical transformation. Though beautiful enough before, it would seem, Manager Davis was not satisfied, and he has spared no expense to make the room a model for phonograph recital demonstrations. The little stage is being removed as the elevation interfered with the acoustics somewhat. By the addition of beautiful draperies and playing from the floor level, a better result is obtainable. The hall is being redecorated in delicate tints and the floor will be laid with a carpet of sea-green and blue shades. New draperies and upholstered chairs will be added also. And not only is the recital hall being reconstructed, but also the private demonstrating rooms. Each room, instead of being bare of wall and coldly business-like, is to be refurnished to resemble a cozy sitting room in a private home. Pictures will grace the walls, rugs relieve the shining hardwood of the floors and draperies and upholstered furniture will further lend a home aspect. Commencing in August daily recitals will be given at the Edison Shop.

Roger Haydock, of the Edison Shop, who has been visiting the laboratories of the Edison Co., in New Jersey, has returned to San Francisco.

Mr. Storms, of the Pacific Phonograph Co., is covering his territory in the Watsonville district.

### In Charge of Dictaphone Department

Paul F. West, who has been for some years the San Francisco manager of the Royal Typewriter Co., and who has won a splendid reputation as a sales campaigner, is now in charge of the Dictaphone department of the Columbia Graphophone Co., Pacific Coast headquarters in San Francisco. Mr. West brought with him from the Royal Typewriter office three of his ablest assistants who are now devoting their energies and enthusiasm to the welfare of the Dictaphone. These persons are: Miss McKim,

who had charge of the employment department of the Royal office; Mr. Matthews and Mr. Coombs, both of the sales force.

### Fred A. Denison in the Northwest

Fred A. Denison, manager of the Columbia Graphophone Co., on the Pacific Coast, is making a trip through the Northwest this month for the purpose of visiting the various branches of the company in Seattle, Portland and other cities.

The local branch of the Columbia Co. has been handicapped by the non-arrival of goods from the factory. They are oversold on some machines and records.

J. J. Black, manager of the talking machine department of the Wiley B. Allen Co., allowed himself a vacation this month and spent the time at the Yosemite Valley. He came back greatly refreshed in mind and body.

### W. S. Gray with Domestic Corp.

Walter S. Gray, who is well known in San Francisco as the former manager of the Columbia Graphophone Co., and who has been absent from the city for several months, has now returned as the Pacific Coast manager of the Domestic Talking Machine Corp., a Philadelphia concern. Mr. Gray is an old hand at the talking machine game and he will lose no time in establishing his new line in the Coast territory. The headquarters will be in San Francisco, but no definite location has been decided upon as yet. Mr. Gray intends to inaugurate a lively campaign for trade.

THE  
**WIDNEY**  
COMPANY

MANUFACTURERS OF

**Turntable  
Felts**

Our extensive stock and specially designed machinery enable us to offer you

**Quality-Service  
Price**

We also want to quote you on  
**Felt and Rubber  
Bumpers**

May we submit estimates on your requirements?

**THE WIDNEY CO.**  
Patton Bldg. CHICAGO, ILL.



CHIPPENDALE  
Official Laboratory Model

## *The NEW EDISON*

is so far above mechanical mimicry that it has been accorded a place (by over two hundred of the leading music critics of America) among the finest musical instruments of all time.

The Edison dealer appreciates the fact that such prestige carries great weight with the public and is not slow to take advantage of it. The results are seen in a substantial and ever-increasing business from a clientele of the most cultured music lovers.

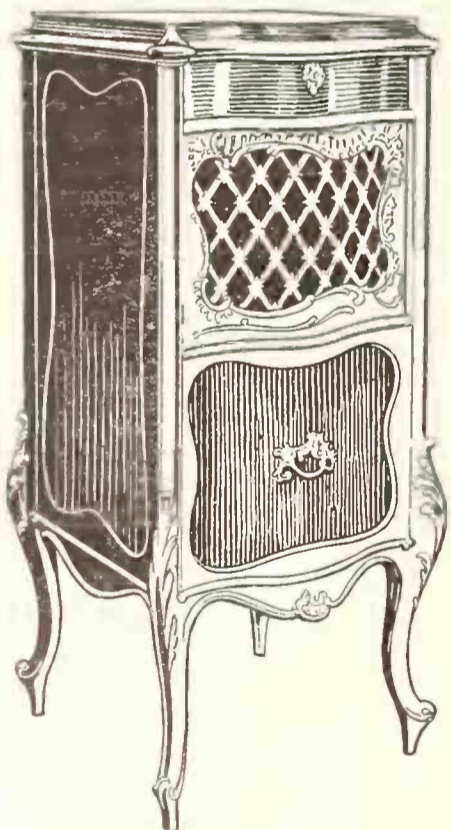

LOUIS XV.  
Model B375

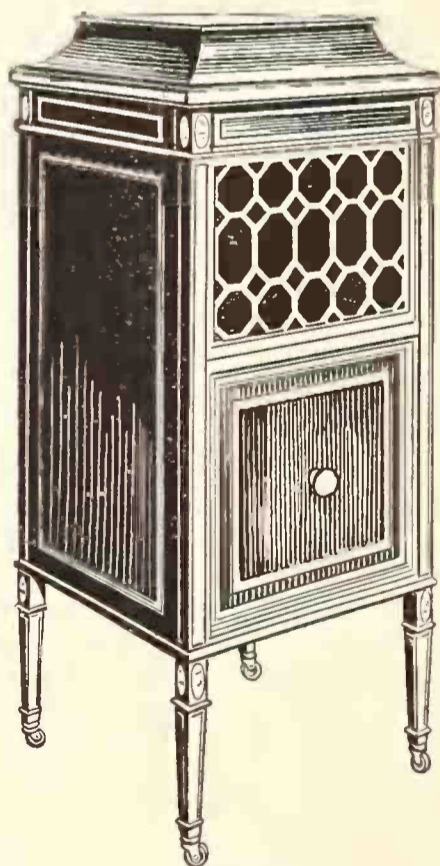

SHERATON  
*Inlaid*  
Model B275

# The *NEW* EDISON

proposition to dealers is not hedged in by petty considerations that hamper and annoy the dealer until he is more concerned about the definition of his franchise than he is about his sales. The Edison dealer policy is as broad and comprehensive as we know how to make it.

When the Edison dealer proves by results that he is thoroughly cultivating his zone of operations, our response is such that, in all fairness, he could not ask more.

**THOMAS A. EDISON, Inc.**  
279 Lakeside Avenue                      ORANGE, N. J.

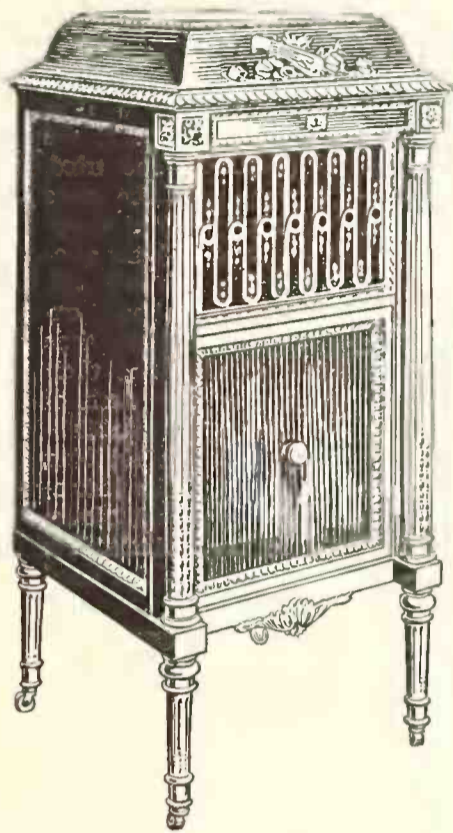

LOUIS XVI.  
Model B450



SHERATON  
*Without Inlaid*  
Model C150

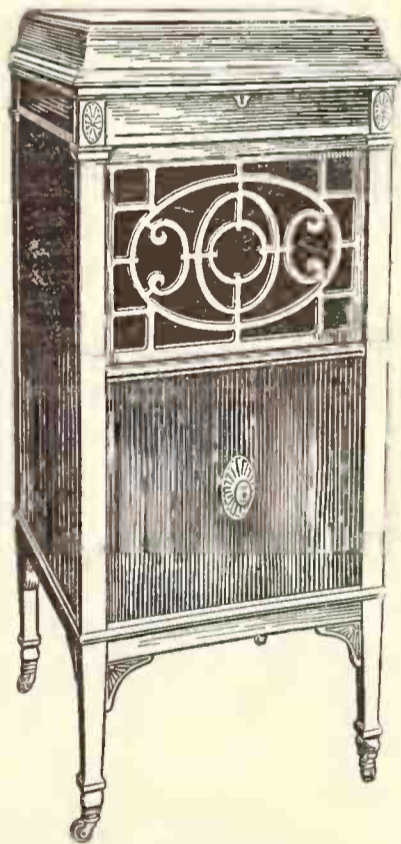

ADAM  
Model C200

# THE TRADE IN BOSTON AND NEW ENGLAND

JOHN H. WILSON, MANAGER, 324 WASHINGTON STREET, BOSTON, MASS.

BOSTON, MASS., August 7.—It will come as welcome news to the talking machine trade at large that at last the dealers are waking up to the need of purchasing early their fall stock of goods. On several occasions this department has called attention to the dilatory attitude of dealers in this matter. Mention of it, it is true, was more or less inspired by some of the large distributors and jobbers who had tried, many times in vain, to impress upon the trade the necessity of placing their orders early. With this issue a new situation, and an altogether encouraging one, can be recorded. Already stacks of orders, as one large house expresses it, are on hand for delivery any time from now on into the fall. These find their way quickly to the factories and the rush of business reported from the home establishments is said to exceed for this time anything that the business has yet known. The indications, therefore, are for an enormous business this fall and winter and it will be sad sledding for those who have not got early on the band wagon.

#### Busy Times with Pardee-Ellenberger Co.

Manager Frederick H. Silliman, of the Pardee-Ellenberger Co., has not as yet found time to get away on a vacation, because, as he says, there is too much business, and it looks just now as though the house would be all sold out before fall. He adds that the firm is experiencing a regular Christmas rush and the indications are that with the present demand for goods keeping up there is to be a very large fall business. Mr. Silliman has one vacation consolation. He is enjoying week-end trips in his new automobile and this gives him a welcome respite from business. W. O. Pardee, head of the company, was over in town the other day and told your correspondent that he was planning to go to Chocura, N. H., about the 12th of the month.

#### Big Columbia Improvements Under Way

Improvements of a rather extensive character are again under way at the Columbia Graphophone Co.'s Tremont street quarters, and one wonders if there is ever to be an end to the changes. But they are demanded by the tremendous growth of the Columbia business, which is increasing surprisingly under the constant eye of Manager Arthur Erisman. At the rear of the ground floor there is a new record room being built which will ease the front of

the store considerably as the records heretofore have been kept there. At the forward end of the floor new demonstration booths are being constructed and these are likely to be constantly occupied. With the three new ones there will be perhaps the largest number of booths of any talking machine quarters in the city. The foreign record department has about tripled in the past year, which is a good indication of the growth of business. Other alterations, too, are under way on an upper floor, which lately was leased to meet the growing demands of business. Manager Erisman, who has not taken a vacation for several years, left last night for Lake Sunapee, N. H., where he and his wife and child will remain for a few weeks.

Fred Erisman, brother of Manager Arthur Erisman, of the Columbia Co., is about finishing his two weeks' vacation. He has had as his guests at his new home in Winchester, his two brothers, Malcolm and Albert Erisman, both from Philadelphia, and they have been let in on the ground floor in seeing the wonders of Boston. A visitor at the Columbia quarters a week ago was W. C. Fuhri, the United States manager of the Columbia Co. Three new women have been added in the past week to the book-keeping department of the company.

#### M. Steinert Co. Happenings

With a well-organized force, Manager Arthur Royer, of M. Steinert & Sons Co., is able to despatch business at a rapid rate these days. System is his watchword and it is seldom that the machinery of business needs oiling in his offices and warerooms. Manager Royer returned a few days ago from Connecticut, where he visited several cities on a business trip. He tells some great stories of the prosperity of the manufacturing centers of that State, where the manufacture of war munitions has been a tremendous stimulus to business activity. He remained home only a few days when he started off in his car for Canada, where he and his family have spent their vacation for several summers. Mr. Royer will go to Murray Bay and several of the places along the St. Lawrence river.

#### New Ditson Building Under Way

The old building on the site of which the Oliver Ditson Co. is about to put its new structure is finally razed and definite building operations will now be begun. Manager Henry H. Winkelmann, of the Victor department, is eagerly

looking forward to the time when he will be occupying his new quarters, which promise to be wonderfully well adapted to his growing Victor business. Mr. Winkelmann is planning to go on his vacation the latter half of August and will take his family to Maine. Otto A. Piesendel, Mr. Winkelmann's valued right-hand man, is already away at Long Beach, Gloucester, where his family preceded him.

#### Closed Excellent July Business

There was a very good July business in both Edison and Victor goods at the warerooms of George Lincoln Parker, besides many prospects ahead. Manager John Alsen thinks that the prospects are good for a large fall business. A scarcity in the receipt of machines is what constitutes the element of worry just now. Mr. Alsen left a couple of days ago for Southport, Me., where he is to be the guest of the Eastern Talking Machine boys at their cottage, "Tis Ours," where they have enjoyed themselves for several seasons.

#### Activity with the Eastern Co.

Speaking of the Eastern Co.'s boys, the first contingent already has left for the Southport camp, these being Ed Welch and Jerry Spillane. As the warm weather is again upon us, they are going away in the nick of time. These boys will constitute a merry bunch.

Business at the Eastern Co.'s Tremont store is all that had been anticipated for July. Manager Elton Taft's son, Elton, Jr., who is a student, is in the store this summer getting some business experience. He will go back to school at the beginning of the fall season.

#### A Visitor from Montreal

Harry Brown, who is pleasantly remembered in Boston when he was with the Eastern Talking Machine Co., is expected in town about the 12th of the month. Mr. Brown has been located in Montreal for the past few years, where he has been able to build up a splendid business. George Reese, who is associated with friend Brown, was a caller on the Boston trade last week.

#### Alterations at the Osgood Co. Establishment

The Victor, Edison and Columbia departments at the furniture store of the C. E. Osgood Co. are being extensively remodeled and redecorated, and in a week or so it will be in handsome shape to welcome customers. Manager Chester J. Sylvester has watched carefully the details of remodeling and has decided on a

RE-CREATION—Edison's New Art, has secured for the New EDISON Diamond Disc Phonograph the stamp of unqualified approval from the cultured music lover who turns a deaf ear toward anything that smacks of mechanical reproduction—the critic who will have nothing short of the actual RE-CREATION of musical sound. Added to this is the fact that every Edison dealer has plenty of "elbow room."

(From a recent advertisement by Thomas A. Edison, Inc.)

We can add to, but not strengthen the truthfulness and accuracy of the foregoing. We can say, however, that two P-E Services are at your disposal—each a separate organization of post-graduate experience.

## THE PARDEE-ELLENBERGER CO., INC.

Edison Jobbers for New England, with complete wholesale offices at  
BOSTON and NEW HAVEN

## THE TRADE IN BOSTON AND NEW ENGLAND—(Continued from page 14)

scheme of white and old gold for the wall-finish interior. There is a new Colonial entrance, which is flanked with white Corinthian columns, which give quite an imposing effect. Mr. Sylvester, who is spending the summer at Winthrop, will go on his vacation the latter part of August and will take with him his brother, Roy, who is with the Columbia Co. Louis Samuels, of Manager Sylvester's staff, is taking his vacation in Montreal. The summer business thus far in this department has been very satisfactory.

**Expanding Its Department**

The large furniture store of A. McArthur & Co. is largely increasing its Columbia and Victor departments and four soundproof rooms are being added to the equipment. The department is being removed to near the main entrance so that no customers entering the store can escape coming into immediate contact with it.

**Enjoying Increased Facilities**

With increased facilities for handling business, the talking machine department of the Iver Johnson Sporting Goods Co., at 155 Washington street, is making marked progress. Manager Arthur W. Chamberlain is just now on his vacation at New Found Lake, N. H., where he has been for several seasons.

**Nelson Furbush on Vacation**

Nelson Furbush, of the Furbush-Davis Co., on Boylston street, is making an extended visit at his father's farm in Freedom, N. H. Mr. Furbush became ill while attending the New York convention and ptomaine poisoning developed which kept him confined to his home for several weeks. He will return to town the latter part of August.

**Steinert's Camp Scene Window**

A camp scene with all the accessories for a pleasant week-end rest is being shown in the Boylston street windows of the M. Steinert & Sons Co. There is the tent with a comfortable looking cot inside, fire and cooking utensils, canoe and gun. The expression of the man standing by the tent tells of pleasant memories and equally happy anticipations. Of course, a camp is not complete without a talking machine, so here is a Victor.

**Larger Vocalion Quarters**

Business at the Vocalion headquarters keeps right along despite summerish weather. Manager R. S. Hibshman is about to branch out in a larger degree and his company has leased the whole of the building it now occupies, and will carry the Weber pianos, in addition to the Vocalion phonograph.

**SELLING HIGH-PRICED GOODS PAYS**

Letters from Two Competing Dealers in One City Offer Proof of Fact to A. C. Erisman—Imparts Some Excellent Sales Advice

BOSTON, MASS., August 7.—Two letters of more than passing interest from Columbia dealers in the same city were received recently at the office of Arthur C. Erisman, New England district manager for the Columbia Graphophone Co. One read: "Send us some more 200's, also some 225 E's. These higher priced machines are our very best sellers." The other read: "We have a \$200 machine we want to exchange for four 50's—send us some small machines in exchange for the higher priced instrument, our trade won't purchase anything beyond \$50 or \$75 models.

Naturally dealer No. 1 was making the big profits in that particular city. Mr. Erisman, carefully weighing the letter from dealer No. 2, immediately wrote him a letter which brought the following reply the next day: "Your letter received—along the line of your suggestions we sold the 200 and took an order for another. We will make it a point to talk these high grade machines. It pays."

In view of the above it is interesting to read Mr. Erisman's letter, which was as follows: "Our Boston sales force are adepts at selling 'de luxe.' As salesmen, no doubt every one of

you Columbia dealers is equally adept. All you need is a hint.

"We never ask a man what priced instrument he wants. We take him immediately to a specially displayed 350. Record A-1735 is kept on this machine for demonstration. We play it at once and no time is allowed the customer to talk price. The salesman shows the fascinations



Arthur C. Erisman

of this style instrument. He talks of the enormous tone chamber, artistic design, delights of such an instrument in the home and at this point (one always being in his pocket) produces an order book and pencil. The salesman who attacks the day's duties without an order book does not deserve the title. Produced at the right time in the right way it will win many a battle.

"At this point we mention the price—\$350—and compare it with the \$500 or \$600 the man would pay for a piano, pointing out that the \$350 purchases the very epitome of perfection

in a Grafonola. Also it is pointed out the Grafonola brings 'all the music of all the world.' If a customer says here that \$350 is more than he cares to pay at present we have a 200 or 225-E flanking the grand and offer these types with the privilege of exchange for a grand within ninety days—and nine times out of eleven we sell at the very least a 110 or 150 and very often the 200 instead of a 35 or 50."

Mr. Erisman's letter as quoted above is worthy of close attention in view of the fact that he has achieved unusual success with the higher priced machines. From his very first entrance into the talking machine business he realized that concentration on the sale of the better class of machines would pay handsome dividends all along the line.

As Mr. Erisman has often pointed out to his associates and the Columbia dealers in his territory, a \$200 or \$150 machine in the home will mean a better satisfied customer, will raise the standard of record sales, will prove a thousand fold better advertisement for the dealer's store, and a lot more money for the dealer.

**FORREST GIVING VICTOR RECITALS**

LAWRENCE, MASS., August 8.—J. J. Forrest, Victor dealer of this city, has been attracting considerable attention to his establishment by giving informal concerts, featuring selections by local artists, together with a carefully chosen program of Victor records. Mr. Forrest pays particular attention to the records which he uses at these concerts, in order that the audience may obtain some idea of the unlimited scope of the Victor repertoire. A recent program featured Victor records made by John McCormack, Sousa's Band, Caruso, Fritz Kreisler, the Victor Orchestra and the Peerless Quartet.

The Secretary of State at Wilmington, Del., granted a charter of incorporation last week to the Metronola Phonograph Co., which will make and sell talking machines.

# Needle Questions

1. Who made the first needle?
2. Who makes the most needles?
3. Who has the largest needle factory?
4. Who makes the best needles?
5. Who uses special needle steel?
6. Who does the biggest export needle trade?
7. Who shipped 63,000,000 needles in 10 days?
8. Where should I buy my needles?

**Eight Questions and ONE Answer**



**W. H. BAGSHAW**  
LOWELL, MASS.

# Columbia Record Prestige Columbia Record Demand

Once in a while it is profitable to take a sort of inventory of the *reasons* that justify the prestige that everybody recognizes.

We have reason to be well satisfied that the one word "*tone*" explains it all—coupled with our very successful policy of issuing "All the hits while they *are* hits."

Take our dance records: *You* as a dealer know better than anyone else that in tone, as well as in time and rhythm, they are unsurpassed.

Take any one of our instrumental trios: What but pure, perfect *tone* made this instant and permanent success?

Take our unmatched talking records: "Cohen at the Telephone," or any of the others. Had you any idea that *talking* records could take hold in such extraordinary fashion?

Take our recordings of the violin: Has the violin ever before been anything like so faithfully reflected?

And in musical novelties: What a hit was made by our Hawaiian music, and how the Marimba records sold and resold!

It's the *tone* of such records as these that has made the prestige—and prestige *is* demand.

And the demand for Columbia Grafonolas and Columbia Double Disc Records has been increasing so rapidly that the bare figures—80%, 100%, and now 200% increase over a corresponding period of the past year—are enough to convince any shrewd buyer and seller of merchandise that the demand is healthy, natural and dependable and growing even stronger every week.

# Columbia Graphophone

Woolworth Building, New York





**N**O other trade-mark means so much to music lovers as these Columbia music notes. They are more than a commercial trade-mark — they are a symbol. Trade on this trade-mark—Note the Notes.

pany

## VAN VEEN "BED-SET" SECTIONAL BOOTHS

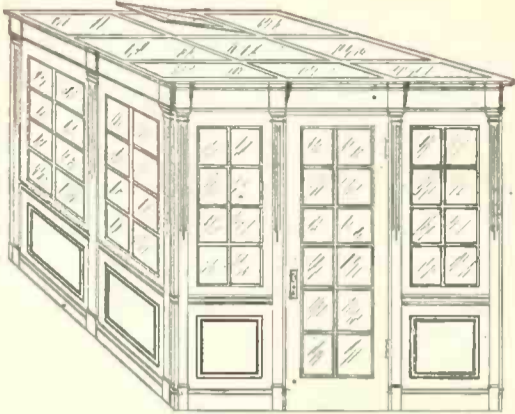

STYLE "A"

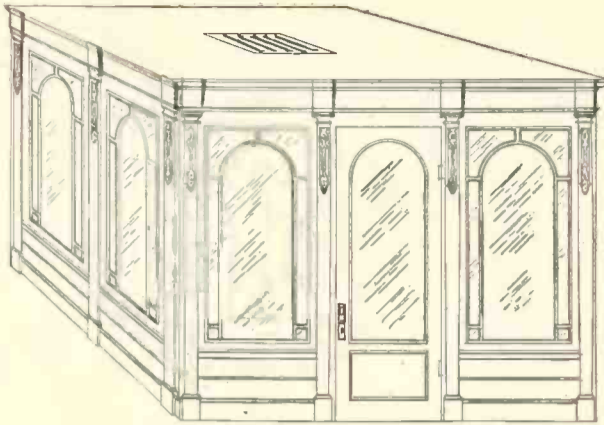

STYLE "B"

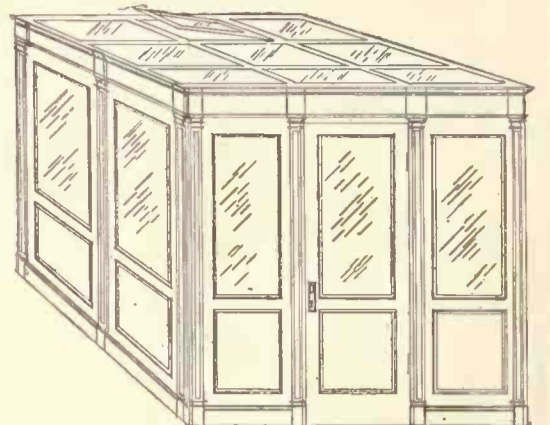

STYLE "C"

Van Veen Bed-Set Sectional Booths can be erected as easily as a bed (no skilled labor required). Booths shipped on short notice anywhere. Room sizes any multiple of 3 feet. High grade finish, will match your sample if desired. Sound proof construction. Mail your requirements for prices and descriptive circulars. We design and build complete interiors.

**ARTHUR L. VAN VEEN & CO., Marbridge Bldg., Broadway and 34th St., New York**

### INDIANAPOLIS TRADE VERY ACTIVE

Hot Weather Does Not Affect Talking Machine Business in That City—Dealers Placing Big Orders for Fall—What the Various Concerns Have to Report Anent Conditions

INDIANAPOLIS, IND., August 3.—In spite of all the freakish turns the weather has taken, the local talking machine dealers are still coming along with reports of "better business than ever." And that is saying something, considering the fact that the past month of July was the second hottest month in the history of the weather bureau here.

There has, of course, not been a brisk demand for the higher priced machines, but the sales of the lower priced machines have kept up the total business.

The wholesalers all report that they are filling many summer orders from dealers who learned last year the folly of trying to get orders filled

during the rush of the winter months. Walter E. Kipp, of the Kipp Phonograph Co., distributors of the Edison, says the last month showed a tremendous increase over July, 1915, and that the biggest worry continues to be the difficulty in getting shipments fast enough from the factory.

A. W. Roos, local manager for the Columbia Co., has rented the storeroom next to the Columbia store for the purpose of maintaining a larger stock to supply the dealers who do not buy direct from the factory. Mr. Roos has secured many summer orders from his larger dealers, among them being the D. Sommers Co., which has been pushing the Columbia machine strongly.

Mr. Roos has not fully recovered from an injury he received when he fell in the street and injured his leg several weeks ago. The accident occurred in front of a recruiting station, where Mr. Roos had lent a Columbia machine, and friends of Mr. Roos say that his attention

was so fixed on the machine that he failed to see the curb. Mr. Roos reports the dictaphone business for the last month as establishing a new record for Indiana, with the talking machine business at least 125 per cent. more than July, 1915.

Frank Carlin, of the Carlin Music Co., in speaking of the talking machine business, said that he was surprised at the way the business keeps up through the hot weather.

Arnold E. Pfeiffer, manager of the Starr Piano Co., is featuring the Starr phonograph in window advertising and is getting results. At the Pearson Piano Co. it was reported that the talking machine department was keeping up its record. Victor machines and records swelled the sales record for July at the Fuller-Wagner Music Co.

E. L. Lennox & Co. reports the business in Victrolas and Edisons continues good. The Rex Talking Machine Co. is doing considerable advertising in the "movies" and with good results.

At the Aeolian Co., the Vocalion is coming right along and it is expected to be one of the leading sellers this fall.

M. P. Tobin, of the Pathé Phonograph Co., reports that his men continue to bring in contracts with live dealers all over the State. Among those signed recently are the W. A. McNaughton Co., of Muncie; Frank A. Brown, piano merchant at Logansport; The Osborn Dry Goods Co., of Noblesville, and the Iroquois Drug Co., of Marion, Ind.

The McNaughton Co., which runs one of the largest department stores in the State, will handle the Pathé exclusively and is devoting considerable space to the talking machine department, which is under the management of Prof. Harry Paris.

At the Stewart Talking Machine Co., jobbers of the Victor line, business continues good. Emerson Knight, advertising manager, and the sales force are passing some of their time these hot days joking with E. W. Fortiner, one of the Stewart salesman, who, they say, has developed the golf fever to such a degree that he is likely at any time to stop talking about Victrolas and begin telling of his latest exploits on the green. Fortiner, however, insists that the better the golf player you are, the better the salesman you are, and he is not letting jokes bother him in the least.

### NEW FILING AND INDEXING SYSTEM

A new system of filing and indexing records has just been introduced by Henry Rosenberg, 14 Wooster street, New York. This system which is known as the "Indexo" phono record holders consists of a set of specially constructed holders which may be stood on edge in the racks or laid in piles on shelves of the cabinet. Each record is filed in a separate holder, and the names of the records may be written on the individual holders, making for maximum convenience in every way.

## Quick Service for Victor Dealers

There's no lost motion in our organization—no red tape methods in our order department. Everybody here is ready and eager to help you to do business. When you want something in the Victor line right off, get in touch with us.

**Telephone to Steinert's  
Oxford 1330**

Remember that we have the largest and most complete stock of Victor records in New England, and that it is yours to command.

**M. Steinert & Sons Co.**  
35 ARCH STREET, BOSTON

# B & H FIBRE NEEDLES

## *Announcement*

THE B & H Fibre Manufacturing Company, *Sole Owners, Patentees and Manufacturers* of the *Fibre Needle* are now in a position to supply their specialty to such of the trade as are not now ordering from the Victor Talking Machine Company or the Columbia Graphophone Company.

The *Fibre Needle* is today a part and parcel of the Talking Machine and Phonograph.

Its place among needles is unique, in that its specific performance is different and quite separate and apart from any other.

The *Fibre Needle* has no competition—it is in a class of its own.

It has been proven to be the only needle that does not injure the record—that eliminates “surface sound” and produces a “round tone.”—*Three Facts to be Remembered!*

The *Fibre Needle* has never failed to repay the dealer, in terms of increased profits and prestige, for all efforts expended in familiarizing his customers with its many advantages.

**B & H FIBRE MFG. CO.**

33 & 35 W. Kinzie Street

CHICAGO

## ACTIVE CONDITIONS PREVAIL IN KANSAS CITY TRADE

Dealers Who Attended Jobbers' Convention Enthusiastic Over Good Results It Produced—  
Governmental Safety Exhibit Train Carries Grafonolas—May, Stern & Co. Department  
Remodeled—Blackman Heads Music Committee of Advertising Club—General News

KANSAS CITY, Mo., August 4.—A. A. Trostler, manager of the talking machine department of the Schmelzer Arms Co., returned the morning of July 28 from the trip he made following the convention of talking machine jobbers. He was accompanied on this trip by E. C. Rauth, of St. Louis. They went up into Canada, where they had a pleasant visit with the Berliner Gramophone Co., at Montreal, and with other dealers and jobbers in talking machines. Coming back to Detroit, they took the boat trip thence to Chicago. Mr. Trostler is enthusiastic over the convention and the good it did. W. E. Lyman, his assistant, efficiently managed the department during Mr. Trostler's absence.

C. J. Schmelzer, president of the Schmelzer Arms Co., who attended the convention of talking machine jobbers, left Kansas City shortly after his return from the East for Colorado, where he will take a short vacation.

The nine cars in the safety exhibit of the United States Government were on side track at Kansas City, two days recently. Each car is equipped with a Columbia Grafonola, and the men made a bee line for the Columbia shop in Kansas City. Mr. Standke, manager of the retail store, had called at the train as soon as it stopped, and inquired as to their needs. They wanted records. And they stocked up with almost a complete new line. The machines have been a great treat for the men with the train, and are kept going most of the time. The music helps the men at the work of cleaning the cars; solaces the lonesomeness of trips, and assuages the boredom of long waits at small towns. The train is going westward again, and these hot days and nights the Grafonolas are expected to make life bearable.

E. E. McMurtry, manager of the Kansas City branch of the Columbia Co., went on his vacation August 1. It was to be a short one, less than a month. He expected to find some cool spots in Estes Park, Colo.

Grant Pauley, a partner in the Kroh Music Co., of Muskogee, Okla., visited the Columbia store in Kansas City on his return from a trip East that had included the Elks' convention. Mr. Pauley is the impressario of Muskogee, and has brought nearly all the great artists there. He arranged for some on this trip. The Kroh Co. handles Grafonolas in Muskogee, and the visits of the great artists are used, with the distribution of Grafonolas, to build up in this

city a desire and appreciation of music that is really wonderful.

E. S. Hall, of the Hall Music Co., has found the summer dull only in spots, for the talking machine and record trade; his sales of Victrolas has exceeded expectations.

John F. Ditzell, manager of the talking machine department of the Geo. B. Peck Dry Goods Co., with Mrs. Ditzell, has returned from the jobbers' convention and several side trips. They visited New York, Syracuse, Washington, Philadelphia, Cleveland and Chicago, in each city inspecting the talking machine departments of the big stores.

The report was given recently of the sending of talking machines and records to the soldiers from Kansas City from the talking machine department of the Geo. B. Peck Dry Goods Co. The machines and records were gifts from Kansas City people to the soldiers, and were purchased at the Peck store—not given by the store.

Charles M. Robertson, in charge of the talking machine department of May, Stern & Co., is delighted with the new arrangement of the department. The present location is near the elevator, and two rooms have been provided besides equipment and decorations far ahead of those in the previous location in the store. The business has responded to the improved surroundings.

An addition to the Victrola department of the Jones Store Co. is Thomas W. Ivey, recently in the phonograph department of the North-Mehornay Furniture Co., and previously with the Southwestern Talking Machine Co., of Dallas, Tex.

Harry B. Bibb, manager of the Victrola department of the Jones Store Co., had to scramble this summer to provide vacations. Indeed, instead of reducing the number of employes, he had to find extra help for the record section. In the large business done the more expensive machines predominate.

The Wunderlich Piano Co. accepts the summer dullness philosophically, and while keeping up its usual pace of advertising and providing attractive windows, has not spread out. "People do not want to stay indoors and listen to new records," said one connected with the firm. "No use fooling ourselves."

Music was an important feature of the annual picnic of the Jones Store Co., at which this

year more than 2,000 employes were present. The store closed for the afternoon. Harry B. Bibb, manager of the talking machine department, was a member of the dance and the music committees.

The talking machine department of the Geo. B. Peck Dry Goods Co. is planning an extensive campaign of advertising, which will probably exceed any of the previous ones. The company is also planning to extend its service in an educational way this fall and winter, when school is in session, and to give the pupils and teachers the fullest co-operation towards the knowledge of and appreciation of good music.

M. M. Blackman, manager of the Edison Shop, of Kansas City, has been appointed chairman of the music committee of the Kansas City Advertising Club.

E. E. Trower, of the E. E. Trower Music Co., distributor for the Kansas City territory of the Pathephone, has made fine progress in the organizing of the district. The company has its salesmen out, who are locating the Pathephone in many of the best cities. Mr. Trower reports conditions favorable and collections especially good.

William Volker, a large wholesaler of curtains, draperies, floor coverings, furniture and hardware, in Kansas City, is now handling the Knabe Crystola over all the territory that the firm covers with its salesmen.

W. E. Rupe, manager of the Starr Piano Co.'s Kansas City branch, with Mrs. Rupe, has gone on a vacation to Grand Rapids. They will return by way of Richmond. The trade at the Kansas City branch has been excellent in phonographs and records this summer.

Miss Minna C. Lee, who has been with the Kansas City branch of the Starr Piano Co. almost since its establishment, was married July 8 to Mr. C. R. Olson.

J. D. McKenzie, representing the Playerphone, was in Kansas City recently, visiting the agents in this territory, the Architects' and Engineers' Supply Co.

### COLUMBIA RECORDS BY DE PACHMANN

The Columbia Graphophone Co. is announcing in its September supplement the first records by Vladimir De Pachmann, the world-famous pianist, who has achieved international renown as an interpreter of Chopin's music. The selections played by De Pachmann for the Columbia library include Liszt's famous "Polonaise-Cadenza" and Chopin's Etude, Op. 25, No. 3, No. 3 in F Major and Prelude Op. 28, No. 16 in B Flat Minor. The splendid piano tone of these records has won considerable praise from pianists who have visited the Columbia laboratory and heard them.

## We Fill Your Orders

### Records:

You cannot afford at this time to be without the services of a Jobber who guarantees to fill your orders.



**ECLIPSE**

### Machines:

Almost daily shipments by the Factory and by concentrating our efforts enables our extending unequalled service.

Cleveland is the logical Center between New York and Chicago and our Shipping Facilities are unequalled. You save Time, Increase your Profits and reduce operating expenses.

A TRIAL WILL CONVINC

**ECLIPSE MUSICAL CO., VICTOR**  
CLEVELAND Distributors

**They are telling us that the recordings by the Taylor Trio are among the fastest money makers in the Columbia Instrumental list. Are you taking advantage of this?**

(Write for "Music Money", a book "full of meat" for those dealers interested in quick and frequent turnover of capital.)

**Columbia Graphophone Co.  
Woolworth Building, New York**



## TALKER TRADE IN CANADA SHOWS STEADY PROGRESS

Columbia Sales Constantly on the Increase, Declares Ralph Cabanas—Pathé Frères Pathéphone Co., of Canada, Ltd., Organized to Distribute Pathé Goods—General Expansion in the Trade Through the Entrance of Many New Wholesale and Retail Dealers

TORONTO, ONT., August 5.—Among the few representatives from Canada who visited New York recently was Ralph Cabanas, manager of the Canadian division of the Columbia Graphophone Co., with headquarters in this city. Mr. Cabanas had only returned from his Western trip a few days when business required his presence in New York, where his family had gone while he was absent in the West. Activity in the talking machine trade in the United States he thought to be just as pronounced as in Canada, with the various manufacturers making abnormal efforts to take care of the dealer's demands. Mr. Cabanas is quite elated with the continued increase in Columbia sales in Canada and the prospect of his firm catching up with sales at an early date.

R. P. Newbigging, head of the Newbigging Cabinet Co., Ltd., of Hamilton, who visited New York recently, speaking of the talking machine trade, said: "Everything points to a very busy fall trade in the United States and that will likely mean a shortage for Canada."

A new firm was organized and incorporated with an Ontario charter to distribute and eventually manufacture Pathé lines in Canada, under the name and style of the Pathé Frères Pathéphone Co., of Canada, Ltd. The headquarters of the company are at 215 to 219 Victoria street, Toronto, a five-story brick block owned by W. J. Craig, who is managing director of the new corporation. Associated with Mr. Craig on the executive staff are James Malcolm and N. G. Valiquette, of Montreal. The latter has one of the largest and most successful retail furniture and furnishing houses in Canada. Mr. Malcolm has old established and progressive furniture manufactories at Listowell and Kincardine. The firm, of which he is the head, was established many years ago by his father, the late Andrew Malcolm, of Kincardine, and a former member of the Ontario Legislature. This firm is rated among the most advanced furniture manufacturing establishments in the country, and has a wide reputation for up-to-dateness. Mr. Craig, who will be the active head of the new concern, has had a long career in the furniture industries in Canada, in which he is well known and has made an unqualified success. For many years he has handled the products of the best Canadian factories in addition to imported lines. He maintains permanent show rooms in his building on Victoria street, Toronto, where the headquarters of the Pathé Frères Pathéphone Co., of Canada, Ltd., are located. The management of the Pathéphone and record business is vested with Henry Pratt, formerly on the selling staff of the R. S. Williams & Sons Co., Ltd., and latterly in charge of the retail phonograph department of Frank Stanley. While it is the purpose to manufacture

in Canada, Pathéphones and records are in the meantime being imported from the factories of the New York concern, with which the new firm is linked up with as well as the parent firm in France. Referring to the prospects for doing business Mr. Pratt stated to your correspondent that so numerous have been the inquiries for agencies even before they were ready to make any definite announcement that they have been unable to take care of them all.

To be prepared for the fall rush and in line with their policy of service, the Music Supply Co., of Toronto, has leased additional wareroom space in order to handle a larger stock of Columbia Grafonolas than they have ever carried. Having in mind the shortage that has existed and the increased demands that it is confidently expected will be made on the talking machine trade this fall they have placed unusually heavy orders in the hope of being able to accumulate stock in advance to take care of early fall deliveries. The Columbia factories are gradually catching up with orders and hope to be in a position by the end of the summer to fill all orders immediately.

Otis C. Dorian, assistant manager of the Columbia Graphophone Co., Toronto, is among

the members of the music trade spending a vacation in the "Highlands of Ontario."

I. Montagnes, of I. Montagnes & Co., Toronto, the Canadian distributors of Sonora phonographs, has returned from a visit to the Sonora factories at New York. Mr. Montagnes was well pleased with the goods he was able to secure for immediate delivery which, he states, will take care of orders.

C. R. Coleman, late manager of the R. S. Williams & Sons Co., Ltd., branch, at Montreal, has returned to his home city of Toronto, where he is now manager of Thos. Claxton, Ltd. The latter firm is retailer and wholesaler of musical merchandise and has an extensive trade, featuring Edison and Columbia lines.

The home of J. D. Ford, the energetic and popular manager of the R. S. Williams & Sons Co., Ltd., retail phonograph department, in this city, was favored by a recent visit from the stork, who left a miniature edition of the head of the house.

The demand for the first recordings of Florence Macbeth has been exceptionally good.

The A. A. Langford Co., London, Ont., has taken on the representation of the Sonora.

### JOINS COLUMBIA AD STAFF

Charles Wm. Wolfe, for five years a member of the advertising division of the Corn Products Co., has recently joined the advertising staff of the Columbia Graphophone Co., New York.

## INDIANA VENEER & PANEL Co. HOOSIER PANEL Co.

NEW ALBANY, IND.

Two modern Panel Plants under one efficient management.

Four years' experience as manufacturers of complete

## Phonograph Panel Work

ALL WOODS

Large quantities figured African Mahogany; Quartered White Oak and American Walnut carried at all times. Prices quoted per complete cabinet on various models including all panels. Orders or contracts taken for so many cabinets of various models per week or month.

Shipments made in complete sets cut to size and sanded. Such advantages eliminate much detail from your office and factory and enable you to increase cabinet production which means additional profit.

Write for more complete information or have our representative call and name prices on your various models and explain the advantages of our system.

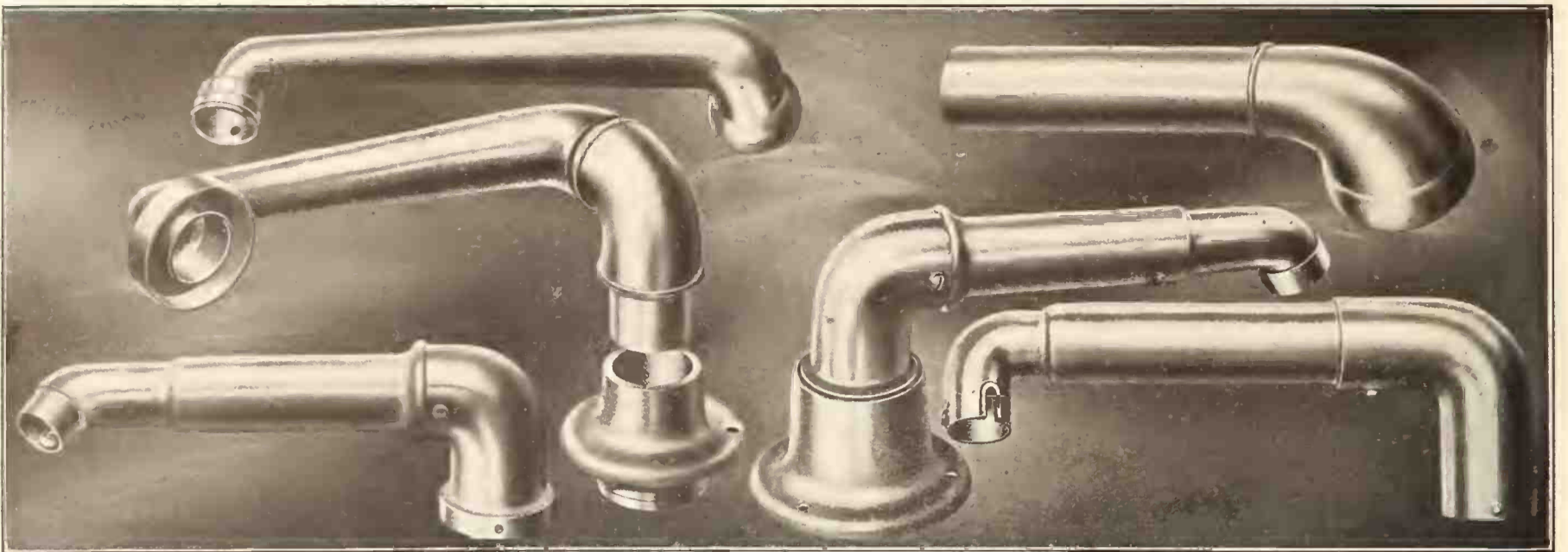

### These Pictures Tell a Story

The story of *quality*.  
 The story of *unfailing accuracy and uniformity*.  
 The story of *lightness and strength*.  
 The story of *large production and prompt deliveries*.  
 The story of **DIE-CASTING SERVICE**.

*Specify*

# Acme Die Castings

for all-around satisfaction in Talking Machine parts. There can be no finer product. Acme Die Castings are made by an organization of practical men who have had years of experience in Phonograph work, and who have developed special machinery and compounded special metals for obtaining *unusual results* in die casting.

Tone Arms and Sound Boxes cast the Acme way will give you what you must have—light weight on the record, due to thin but strong and uniform walls.

We can meet exceptional requirements and save you a large percentage of the cost of parts which have to be cast and machined or made from tubing. Acme Die Castings are ready to plate or assemble when you receive them—and you get them when you want them, and in the desired quantities.

### Consult Our Engineers

They are ready to help you realize the utmost benefit from the Die Casting Process.

## Acme Die Casting Corporation

Bush Terminal Bldg., 35th St. and 3rd Ave.  
 Brooklyn, N. Y.



### Sales Offices:

Boston—176 Federal Street  
 Detroit—965 Woodward Avenue

Philadelphia—Widener Building  
 Chicago—232 S. Clark Street



**MIDSUMMER RECITALS SUCCESSFUL**

**Emergency Ventilating System in Edison Shop in Kansas City Makes Recital Hall a Haven of Rest in the Hot Days—A Piece of Enterprise That Should Appeal to Other Dealers**

KANSAS CITY, Mo., August 7.—Here's one instance of the methods which have held up the sales of the Edison Shop at Kansas City during the summer months. It is one of the reasons that July looked like a winter month, from the standpoint of the visitors and buyers in the Edison Shop. The concert room was hardly without an audience any part of the day, and on some of the hottest days there were comfortable crowds.

The reason: The room was comfortably cool. And Mr. Blackman advertised the fact that it was cool. He had had the men build chutes for air passages from the concert room to the rear of the store, chutes made out of cases in which machines had been shipped. Similar air tunnels were led to the various demonstration rooms and to the reception room. In the rear window a great exhaust fan was erected, similar to those used by restaurants for their kitchens. This fan drew the cool air from the clean basement through the various rooms, and indeed from the entire store, out into the alley and away. Below the stage in the concert room was the ventilator through which the cool air reached the room, and it had to pass over the auditorium to reach the exit shaft, into which it was pulled by the exhaust fan. The room was delightful—and Mr. Blackman advertised the pleasing fact to the limit.

In the front window was a display of machines and records, and apparently casually a few ribbons were attached to them. The exhaust fan caused a current of air that kept these ribbons constantly agitated, and the fact of a breeze was apparent. A large card in the window bore this inscription:

"A cool breeze blows through delightful Diamond Disc Hall. Step in, rest a bit and hear 'My Laddie,' Anna Case."

The name of the record was on a separate card, and changed frequently.

This usually caused the passerby to hesitate a moment by the door of the store. And on this door was another sign:

"You are welcome in this store. Rest in Diamond Disc Hall. Real music; fresh, pure air; continuous program."

If the visitor opened the door he felt a current of cool air pulling him in—a breeze in fact—and it was certainly enticing in the hot, dry days of July. For July broke all records in Kansas City for heat and dryness.

That was a bit of local advertising, pulling the customers into the store.

**The Paramount Record Brush**

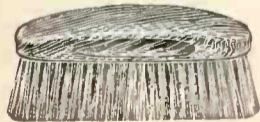

For cleaning the grooves of Phonograph and Talking Machine Records. Removes grit, takes off finger marks, improves the tone. Made of soft black hair, set in solid rosewood backs, highly polished.

Will not injure the Records. Retails for 25c-35c and 50c. Sold by distributors and jobbers of Phonographs and Talking Machines.

MANUFACTURED BY

**Frederick M. Hoyt & Brother**  
Brush Manufacturers  
TROY, N. Y.

**Are You Making The Most of Your Opportunities?**

- ¶ Victor dealers who have been and are successful realize that there is going to be an unusual opportunity this fall to achieve even better results and more profits than they have in the past.
- ¶ This can only be accomplished, however, if your stock and service are complete and thoroughly up-to-the-minute.
- ¶ If there is any phase of your business which needs a little more attention than usual routine supervision, this organization is prepared to assist you along practical, helpful lines.
- ¶ May we not serve you?

**G. T. WILLIAMS CO., 217 Duffield St., Brooklyn, N. Y.**

*Victor Wholesale Exclusively*

**TALKING MACHINE FOR FUNERALS**

Instrument a Gift to Calvary Cemetery for the Benefit of the Poor

An experiment was made with talking machine music at two funerals recently held in the chapel in Calvary Cemetery, at which Father Lonergan, chaplain of the cemetery, officiated.

Thousands of burials are made yearly in Calvary Cemetery, and in many instances the families are too poor to pay for music. It was this that recently led two women to present to Father Lonergan one of the latest styles of talking machines, with appropriate records, in memory of their dead sister.

Father Lonergan declined to disclose the names of the donors, but said they were interested in having suitable music rendered at the funerals of the poor. The machine was set up in the chapel in Calvary Cemetery, which is a reproduction of a famous chapel in Rome.

**NEW COLUMBIA STORE IN NEWARK**

Donald Co. to Handle the Columbia Line—Recent Publicity—Vacations Still Under Way

The Columbia Graphophone Co.'s local wholesale division, 83 Chambers street, New York, closed arrangements last week with the Donald Co., Newark, N. J., whereby this concern will install a Columbia department and handle the complete line of Columbia products. The Columbia line has been increasing steadily in popularity in Newark and the surrounding territory, and the Donald Co. expects to feature the line extensively.

**NEW EDISON BOOKLET**

"A Scot and a Belgian" is the peculiarly opportune title of a leaflet just issued by Thomas A. Edison, Inc., of Orange, N. J. The title of the leaflet is derived from the fact that Christine Miller and Alice Verlet were recently featured in the Edison national advertising. Christine Miller is of Scottish descent and, as every-

body knows, a noted contralto. Alice Verlet is a Belgian and besides being an ardent devotee of the land of her birth, she is one of the leading coloratura sopranos.

**INCORPORATED**

The Paddock Diaphragm Co., of Brooklyn, N. Y., was incorporated recently for the purpose of making diaphragms for talking machines and dictaphones. The capitalization is \$10,000, the incorporators being H. D. Watson and L. M. and S. D. Paddock.

**Nicholson Record Cabinets and also Record Sectionals**



Record cabinets, piano player roll cabinets, fitted with horizontal shelves or upright.

Also manufacturers of the Nicholson Elastic Sectional Book-cases, in all the popular styles.

*Write for 1916 Catalogue*

**K. Nicholson Furn. Co.**  
Chase City, Va.

Samples and Salesmen { 9th Floor, New York Furniture Exposition Bldg.  
High Point Show Rooms, High Point, N. C.  
and  
Furniture Buyers' Exchange, High Point, N. C.

## DEMAND FOR GOOD SALESMEN IN CINCINNATI TRADE

Business for July Reported Satisfactory—New Corporation to Promote Crystola Talking Machine Being Formed—Leading Jobbers in All Lines Make Cheery Reports on Trade Outlook—Dealers Stocking Up in Anticipation of an Unusually Lively Fall Trade

CINCINNATI, O., August 5.—While no official information is available it is understood that steps have been taken towards the formation of a new corporation which will take over all the rights connected with the Knabe Crystola talking machine, introduced less than a year ago.

Officials of the company decline to discuss the present stage of the negotiations. It is intimated that a corporation, having a capitalization of \$750,000, has practically been formed for the purpose of manufacturing the Crystola. The talking machine is to be separated from the Knabe Bros. Co., although officers of the latter concern, it is intimated, will continue to have a financial and probably an executive interest in the production of the Knabe Crystola. Much Cincinnati capital is to be invested in the corporation, it is said.

One of the great drawbacks of the retail houses about Cincinnati is the inability of the dealers to secure the proper kind of salesmen. Several of the owners admit that their poor showing of the past thirty days was principally due to the lack of efficient help and their inability to secure men who are willing to take up the selling of talking machines as a life vocation.

In a general way the business of July was satisfactory. Manager Dittrich, of the Victor department of the Rudolph Wurlitzer Co., covers the Cincinnati situation as follows:

"The past month was extremely hot and the business suffered accordingly, in a retail way. When the instinct of self-preservation makes everyone seek protection from the terrific heat it is practically impossible to push the sale of Victrolas or to expect much attention on the part of prospective buyers. However, even with the big handicap of extremely hot weather, the business was up to its normal, and the demand for records was about the average for this time of the year.

"In a wholesale way, however, business was extremely good. There is never an idle moment either in our machine warehouse or the wholesale record department, and orders are piling in in such quantities that it is evident that most of the dealers are determined not to go into the busy season unprepared, and the numerous record orders also indicate that the record end of the talking machine business is just coming into its own and receiving the attention that it merits.

"It is evident that the volume of business will be determined not by the demand, but by the supply, and as dealers are purchasing all the machines that they can lay their hands on, the shortage apparently will continue just as acute as it has been during the last six months, and in fact, grow worse every day among those dealers who have not taken time by the forelock and prepared in advance for the fall and winter business by purchasing liberally in machines and records."

Nothing will be done towards the establishment of a phonograph department in connection with the Middle West branches of Steinway & Sons until the return of Divisional Manager R. E. Wells from his vacation. Mr. Wells is rusticated somewhere in the neighborhood of French Lick Springs.

Manager R. J. Whelan, of the Cincinnati branch of the Columbia Graphophone Co., remarked that the same terrific demand exists for all types of Grafonolas, and there is still a great shortage of machines for which he is holding bona-fide orders. He has been assured that the factory will bring them through shortly, taking care of the great demand which will surely follow after the present hot spell has passed. He said further:

"While the business in Cincinnati proper has been a little slow, as far as the machine industry goes, the record trade has been splendid,

and there seems to be a demand for all the records we get out, both popular and classic." The major portion of the Cincinnati store have had their vacations, and are all back in harness again, awaiting the rush which is sure to come in the very near future.

Mr. Byars, manager of the Vocalion department at the Aeolian Co. here, reports a nice increase in July business over last year. The hot wave at the close of the month unquestionably cut down on the floor sales, but not sufficiently to overcome the big lead of the first two weeks. Record business has been remarkably good and indications point to an exceptionally big record business in spite of the summer heat. The great difficulty in the phonograph business, according to Mr. Byars, is the

development of good salesmen. The energetic, enthusiastic and intelligent chap, which is the only raw material you can accept for training, is a mighty scarce article. The market is flooded with the cultured, refined little fellow, who would love the work provided he can have two hours leisure in the morning and three in the afternoon. The fellows who really want to work are certainly as scarce as hen's teeth.

The Otto Grau Piano Co. is now stocking up for a busy fall season. The Cable Piano Co. is doing likewise. The Phonograph Co. is commencing to receive select records which have been in demand for months, but could not be filled on account of the recent fire at the factory.

The Phonograph Finance Co., Cleveland, with a capitalization of \$5,000, has been chartered by John H. Price, Phelps Crum, E. E. Maynard, V. L. Polear and C. D. Sutton.

A new Edison phonograph store has been opened at Edgerton, Ind., by Ray Hosack, son of W. L. Hosack, who handles the Edison line in Angola, Ind.

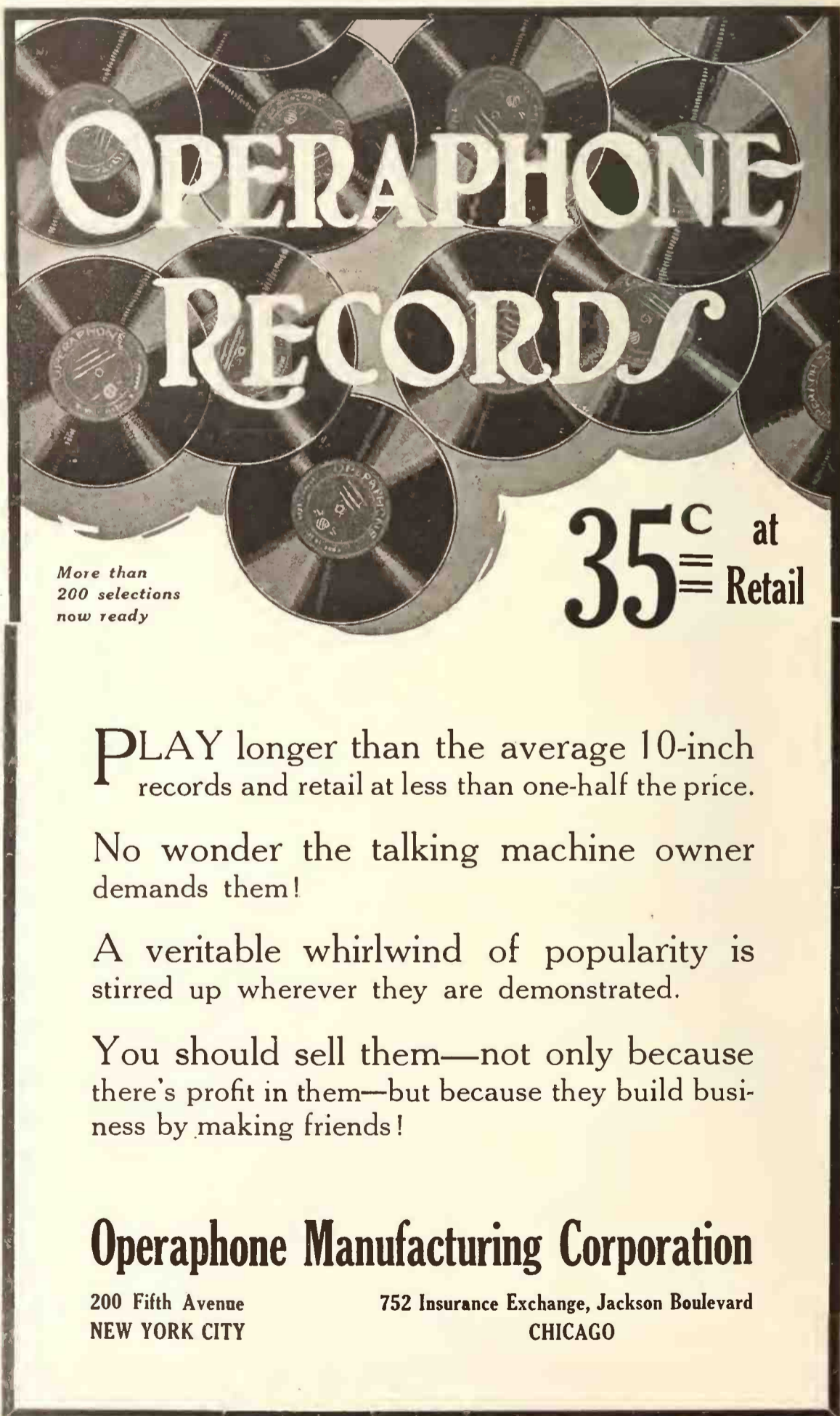

**OPERAPHONE RECORDS**

More than 200 selections now ready

**35<sup>c</sup> at Retail**

**PLAY** longer than the average 10-inch records and retail at less than one-half the price.

No wonder the talking machine owner demands them!

A veritable whirlwind of popularity is stirred up wherever they are demonstrated.

You should sell them—not only because there's profit in them—but because they build business by making friends!

**Operaphone Manufacturing Corporation**

200 Fifth Avenue NEW YORK CITY      752 Insurance Exchange, Jackson Boulevard CHICAGO



Every month there is less substituting of other product when *Columbia* is asked for. It is clearly impossible to substitute any other recorded voice for that of *Graveure*, for instance, and extremely hard to argue some other instrument for a *Columbia Grafonola*. So why should any dealer try it?

(Write for "Music Money," a book "full of meat" for those dealers interested in quick and frequent turnover of capital.)

**Columbia Graphophone Co.**  
Woolworth Building, New York



### TALKING MACHINE MEN'S OUTING

Organization to Hold Annual Affair on September Sixth—Elaborate Program

Secretary Sol. Lazarus, of The Talking Machine Men, Inc., has sent out a circular announcing that the annual outing of the association will take place September 6, at Rye Beach. The entertainment committee is working hard to assure the success of the affair, and an elaborate program of games has been arranged. Baseball games between the nines of the New York Talking Machine Co. vs. the G. T. Williams Co., and between the Blackman Talking Machine Co. vs. the American Talking Machine Co., are expected to be among the features.

Tickets are \$3 a person, including an automobile ride from Twenty-third street, New York City, to Rye Beach, an excellent shore dinner and a return ride. Those who desire to attend the outing are requested to communicate at once with Secretary Lazarus, at 216 East Fifty-ninth street, stating the number of tickets they will require.

### COLUMBIA MACHINES FOR EXPORT

Illustrated and Described in New Catalog Just Issued by Columbia Graphophone Co.

The Columbia Graphophone Co.'s export department has just issued a very attractive catalog listing the various machines in the Columbia line designed for export trade. Quite a number of these machines are intended exclusively for export use, embodying distinctive features appealing to this class of trade.

This catalog is very artistically arranged, particular care having been taken to make the translation of the descriptions accurate in every detail. The cuts used are clear and distinct, the cabinets being colored to resemble mahogany.

Among the machines listed in this catalog are the following, the names given being the terms used in export trade: "Armonia," "Bijou,"

"Meteor," "Lyric," "Melodia," "Eclipse," "Campeon," "Joya," "Favorita," "Esterlino," "Jefe," "Mignonette," "Nonpariel," "DeLuxe" and "Grand."

### A POST CONVENTION PICTORIAL

How Some of the Delegates Looked After Motoring to Camden from Atlantic City

The accompanying photograph, which shows a set of two perfectly good tires, was snapped in front of the office building of the Victor



Some Conventioneers Snapped

Talking Machine Co., Camden, N. J., during the last convention. Reading from left to right are Thomas Towell, of Cleveland, O.; J. C. Roush, Standard Talking Machine Co., Pittsburgh, Pa.; Miss E. Trostler, Glad Henderson, of The Talking Machine World; Charles Bruno, of C. Bruno & Sons, Inc., New York; Miss M. Lightner, of Pittsburgh, Pa., and three auto horns. The photograph was snapped by E. G. Evans, the party just arriving from Atlantic City to visit the plant of the Victor Co.

B. L. Malone & Co., Grady, Texas, are among the recent additions to the Edison phonograph dealers in that territory.

Mrs. Flora W. Axelby, of Newark, N. J., is collecting talking machines and records to be sent to the regiments on the Mexican border.

### DEALER MUST GO AFTER TRADE

Widespread and Good Advertising Alone Will Not Produce all the Results, Declares M. M. Blackman, of Kansas City

KANSAS CITY, Mo., August 4.—M. M. Blackman, manager of the Edison Shop at Kansas City, the local retail store for the distribution of Diamond Disc machines, was known to have been doing rather extensive local advertising, and he was called upon for comment on the effect of advertising at a meeting of the Kansas City Advertising Club.

"Local advertising has certainly pulled the business into our store," he said. "There isn't any doubt that the dealer has to go after his trade for himself. He can't expect any amount of national advertising to build up his personal trade. On the other hand, a comparatively small amount of national advertising, shrewdly taken advantage of by a dealer, and supported by careful local advertising, will yield big returns. But the local advertising undoubtedly is necessary."

The Edison Shop, of Kansas City, has had rather a remarkable record the past few months—which can be credited largely to the local advertising.

### SUFFER FROM GREAT EXPLOSION

Quite a number of the local talking machine stores suffered from the effects of the munitions explosions in New York harbor on Sunday, July 30, and in the different parts of the city show windows were completely destroyed by the explosion. Among the downtown stores whose windows were shattered were the Columbia Graphophone wholesale division, at 83 Chambers street, and the Blackman Talking Machine Co., 97 Chambers street. The most annoying part of the loss of these windows is the fact that they cannot be replaced for several weeks, owing to the shortage of glass at the present time.

## VICTOR RECORD SALES ARE CASH SALES

ARE YOU PUSHING VICTOR RECORD SALES FOR ALL THERE IS IN IT?  
DO YOU PUSH RED SEAL RECORDS?

**DO IT NOW**

THE COMBINATION OF "AMERICAN SERVICE" AND YOUR EARNEST EFFORTS WILL  
PRODUCE RESULTS—AND PROFITS

**BE AN AMERICAN DEALER**

**AMERICAN TALKING MACHINE COMPANY**

368 LIVINGSTON ST.

BROOKLYN, N. Y.

## SEMBACH WITH COLUMBIA

Noted Wagnerian Tenor Has First Records in September Supplement

The Columbia Graphophone Co., New York, has announced the addition to its list of famous artists of Johannes Sembach, Wagnerian tenor of the Metropolitan Opera Co., New York. His first records are in the September supplement and include a number of the selections which



Johannes Sembach

have made him internationally prominent in operatic circles.

Johannes Sembach, in addition to achieving world-wide fame as an interpreter of Wagnerian opera, is one of the few operatic tenors who sing equally well in three languages—French, Italian and German. He has also made a country-wide reputation during the last few seasons as an out-door singer, having sung at the Yale Bowl presentation of "Die Walkure," in the title role of "Siegfried," in Pittsburgh, and in a number of other performances under the open sky.

## A NOVEL VICTROLA SAVINGS PLAN

The A. B. Clinton Co., of New Haven and Hartford, Conn., which has been very successful with the Victor line, has made a specialty of introducing original advertising matter at opportune times. This literature has produced excellent results, primarily because it was "off the beaten track" and contained a personal, human interest message.

A recent piece of advertising distributed by the company consisted of a savings bank envelope, bearing this copy: "Just see how easy it is to slip a few nickels, dimes and quarters, now



## THORPE ELECTRIC MOTORS

FOR TALKING MACHINES (Operates on all currents)

WALTER THORPE, Manufacturer, 29 West 34th Street, NEW YORK CITY

and then, into this Victrola dime saver. When it contains \$5 bring it to us and select your Victrola. We will send it to your home at once and furnish you with another Victrola bank, and in this way you will have a fine Victrola and not miss the money."

## ENTERS THE CABINET FIELD

John J. Cavanaugh, 452 Fulton street, Brooklyn, N. Y., has placed on the market a complete line of cabinets, known as the "Cavanaugh" cabinets, which are designed to match Victor table machines, and in the comparatively short while they have been before the trade, have been the subjects of considerable praise from the dealers.

Mr. Cavanaugh has been associated with the talking machine industry for many years, and in designing his cabinets, he utilized the experience which he had garnered during that time. He aimed particularly to have the Cavanaugh cabinets match perfectly the instruments which they were intended to accommodate, and to this end, embodied a number of distinctive features which have contributed materially to the success of his products.

## ANNOUNCE NEW RECORD LABELS

Operaphone Records to Have Paper Labels in Black and Gold—Factory Output Trebles

In connection with the steady improvement of its product, the Operaphone Manufacturing Corp., New York, has made arrangements to supply all its records in future with attractive paper labels in black with bright gold letters. The new label not only adds to the appearance of the record, but makes it easier to see at a glance the name of the selection. Since the first of the year the demand for the Operaphone records has increased at a rapid rate, with the result that the output of the company's plant in Long Island City has been trebled in that time. With branches in Chicago and other cities, the problem of distribution is being handled very successfully, and the list of Operaphone dealers is growing steadily.

## HOW TO "RAISE" RECORD BUYERS

Hints Regarding the Raising of 75-Cent Record Buyers into \$3 Class

"How to raise a 75-cent record buyer to the \$3 class" is the title of the following pertinent and informative article appearing in this month's "Columbia Record:"

"Class in selling psychology called to order! Here's Mr. B. of S. & G. somewhere north of Nyack, complaining that all his customers carry 75-cent pieces in their pockets and never unravel a whole dollar bill at any one time. What's the use of offering the 'Pique Dame Overture' (A-5763—\$1) to a man who never asks for anything over the ¾ \$ mark?"

"Here's the answer. Because anyone appreciating the 75-cent line of Columbia records will appreciate the \$1, \$1.50 and \$3 lines. They may not take your word for it; you may have to do the 'educational' work, but it will pay you well to do it.

"A good lot of selling psychology is necessary and some time is needed, but it will work.

"This is the way:

"Take a customer who is now buying the Taylor Trio and Stellar Quartet records at 75 cents. After one of the usual 'trio' purchases suggest offhandedly, 'I see you enjoy trio music, just listen a moment to one of our Trio de Lutece recordings. You know this trio is composed entirely of master musicians. They are really the epitome of trio perfection—and their records are only 75 cents too.' Then play A-1907. Follow this up by suddenly remembering 'one more really remarkable trio recording' and play A-5789—12-inch, \$1.

"Hint at how much more music is given on the 12-inch record. You have made a start. Keep on playing Trio de Lutece records at every opportunity. They instill an appreciation of higher class music. A little later talk about the beauty of the 'cello in the Taylor records. Suggest hearing a real 'cello record, solo. Play Popper's Spanish Dance by Casals, A-5650—\$1.50. This is brilliant and light music that will appeal to anyone. When your man comes to the point of enjoying Casals you have him where he will enjoy the whole catalog of fine instrumental music.

"Don't force a man from one extreme to another. Make your sales appeal along the lines of his natural likes. A love of music will grow by suggestion. And above all, don't force your sales idea until a man has bought what he wants first. One sale will then be assured and you can develop the next.

"Along the lines of vocal music the same ideas apply. After playing the latest Stellar Quartet selections suggest the customer hear some of the solos by the individual members of the quartet. There you have the entering wedge to oratorios, opera and chorus recordings. Reed Miller's oratorio selection and Harrison's oratorio and operatic selection will gradually impress themselves on anyone who already appreciates these voices in the Stellar Quartet. 'Oh, by the way, here is a record by the second tenor of the Stellar Quartet,' you can say as you put on 'Comfort Ye My People,' A-5506—\$1.25, by Mr. Miller. Never give up. Always play at least one record in the price-class above."

## McMENIMEN HOME FROM WEST

H. N. McMenimen, managing director of the Pathé Frères Phonograph Co., New York, returned Monday from a week's stay in Chicago. His reports of business conditions in the "Windy City" are most optimistic, for notwithstanding the terrific heat throughout the Middle West, there is a healthy tone to wholesale and retail business which augurs well for the future.

Room 73

65 Nassau Street

Clifford A. Wolf  
MANUFACTURER OF  
Diamond and Sapphire  
Phonograph Points

New York City

Phone, 2124 Cortlandt

# PROMPT DELIVERIES—PHONOGRAPH MOTORS

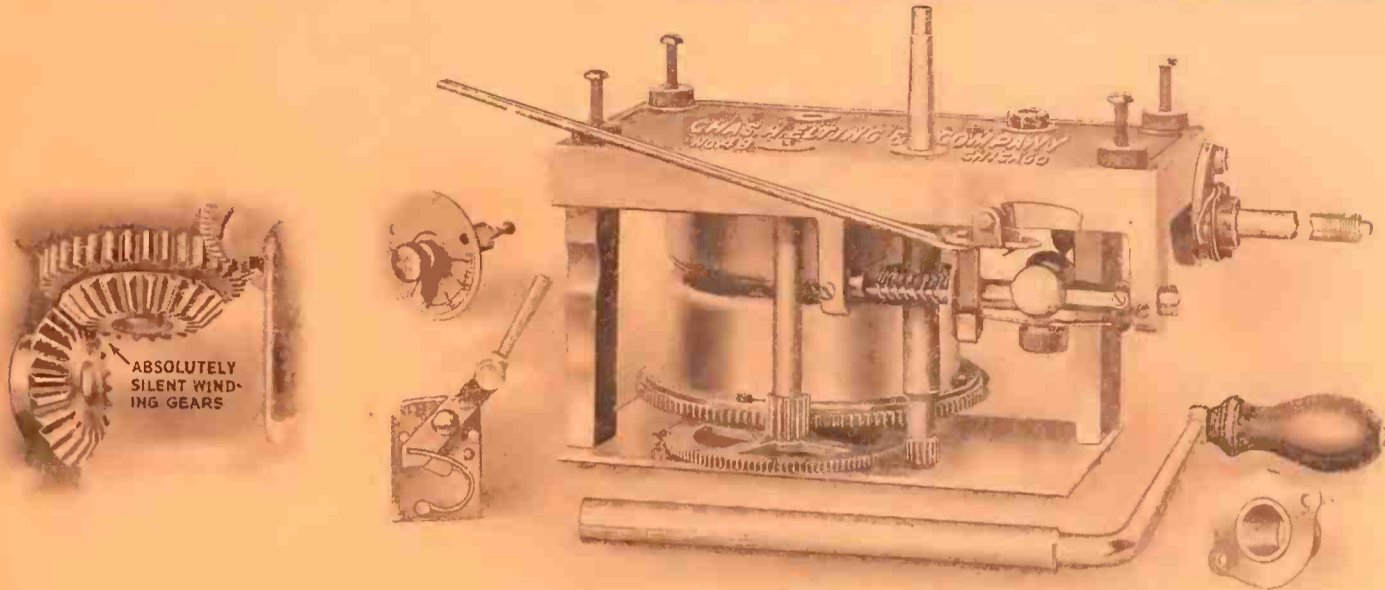

## PLAYING 5-12 INCH RECORDS

No. 4B—Polished and Buffed Nickel Plated Double Spring Phonograph Motor, complete with Graduated Regulator, Stopper, Escutcheon, Four Screws, Four Rubber and Four Steel Washers, **SCREW-ON WINDING KEY**, and either a 12" Stamped (Green Felt) or a 12" Cast (Green Felt) Turntable. **PLAYING 5-12" RECORDS.** This motor contains 2 springs 1" wide by 14 ft. long.

We will send Phonograph Manufacturers, for trial or test purposes, complete sample with BOTH 12" Stamped (Green Felt) and 12" Cast (Green Felt) Turntables on receipt of check or money order for \$7.65. Special quantity prices on application.

If after trying out this Motor you find you cannot use it—return the same and we will **REFUND PURCHASE PRICE IMMEDIATELY.**

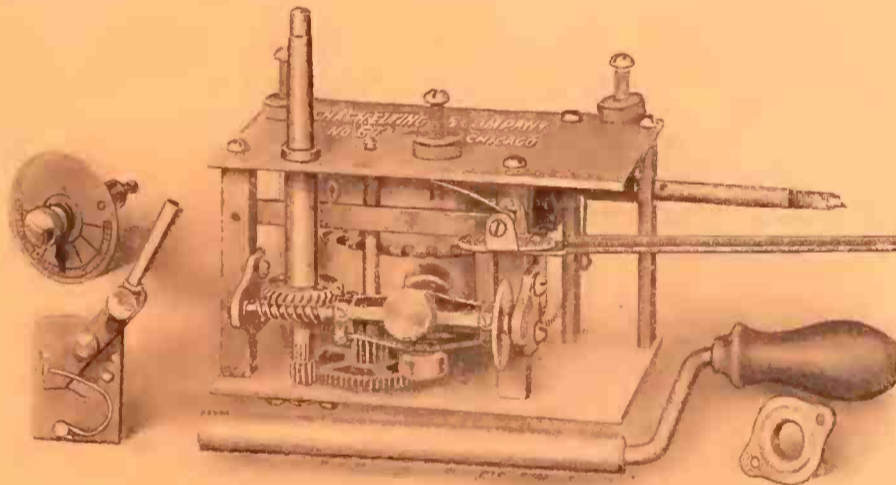

## PLAYING 3-12 INCH RECORDS

No. 6T—Double Spring Phonograph Motor, complete with Graduated Regulator, Stopper, Escutcheon, Three Screws, Three Rubber and Three Steel Washers, **SCREW-ON WINDING KEY**, and either a 12" Stamped (Green Felt) or a 12" Cast (Green Felt) Turntable. **PLAYING 3-12" RECORDS.** This motor contains 2 springs 1" wide by 11 ft. long.

We will send Phonograph Manufacturers, for trial or test purposes, complete sample with BOTH 12" Stamped (Green Felt) and 12" Cast (Green Felt) Turntables, on receipt of check or money order for \$4.65. Special quantity prices on application.

If after trying out this Motor you find you cannot use it—return the same and we will **REFUND PURCHASE PRICE IMMEDIATELY.**

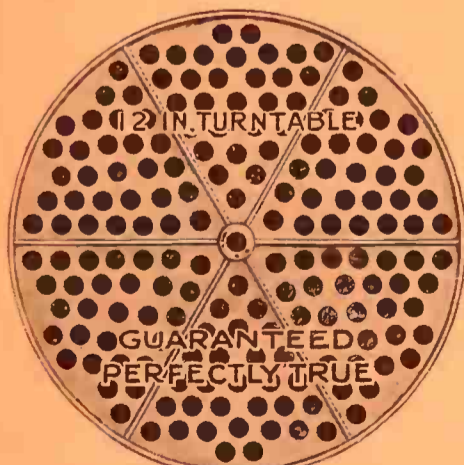

Weight 2 lbs., 14 oz.

12" Cast Turntables, Nickel Plated, Edges Polished and Buffed, guaranteed to run perfectly true and **GUARANTEED TO STAY TRUE RUNNING.** Can't be bent out of shape by leaning on it, or in any other way.

Price for Turntable and gluing on the felt, you to furnish whatever color and grade of felt you choose, ship it to us in circles of the proper dimensions, and we will put it on.

.....43c each



Weight 2 lbs., 6 oz.

12" Stamped Turntables Nickel Plated, Edges Polished and Buffed with Three ribs, which hold it absolutely rigid. We can make prompt shipments of any quantity you may desire.

Price for Turntable and gluing on the felt, you to furnish whatever color and grade of felt you choose, ship it to us in circles of the proper dimensions, and we will put it on.

.....33c each

**CHAS. H. ELTING & COMPANY** 1330 THE REPUBLIC 209 S. STATE ST. **CHICAGO**



**And now Sembach! The greatest of German Tenors has been convinced that his art could properly be recorded and he has just made his first Columbia Double-Disc Records—out August 20th.**

*(Write for "Music Money," a book "full of meat" for those dealers interested in quick and frequent turnover of capital.)*

**Columbia Graphophone Co.  
Woolworth Building, New York**



**MESSAGES FOR KAISER VIA U-BOAT**

**German Submarine "Deutschland" Carries Voices of 800 Interned German Sailors to Their Emperor on Talking Machine Records**

When the German undersea liner "Deutschland" sailed for home last week there was included in the cargo a small package that was not listed in the manifest, but which was nevertheless of immense value to those interested in it, for the package is addressed to the Kaiser personally and carries to him the actual spoken messages of the 800 or more German sailors interned at Norfolk, Va.

The packet contains a dozen or more phonograph records and to the interned sailors in Norfolk it has a greater value than all the rest of the entire cargo of the "Deutschland." For months the German sailors wondered how they could get messages to the fatherland. The mail service was out of commission, thanks to the British censorship.

It seemed to them for a long time that no means would be found to communicate with their families. Hope came with the arrival of the submarine and her sturdy crew, and the interned sailors at once became active. Hundreds of letters were written, mail bags were filled with messages to dear ones at home. But something was lacking in them, the ability to transmit the human voice.

With characteristic ingenuity, the men decided to make a series of phonographic records, to sing into them the patriotic and folk songs of the fatherland. The blank records were quickly obtained, every one of the 800 men having a voice in the making of some records. Never was "Die Wacht am Rhein" sung with greater fervor, according to this information from Norfolk. It was followed by "Deutschland, Deutschland ueber Alles." So carried away with enthusiasm were the sailors to show love for the fatherland that they included the Kaiser's favorite hymn, by Luther, "Eine fester Burg ist unser Gott."

"In der Heimat giebts ein Wiedersehn," "Ich bin ein Preusse," "Kennt Ihr meine Farben" and several other equally well known.

One officer recited into a record the loyalty of his men and their longing to get back to their people. When the records were finished they were securely wrapped in stout paper and addressed to the German Emperor. The parcel, which has a sentimental value to every one of the 800 men interned in Norfolk, was tenderly given to the care of Capt. Koenig, who promised to see to it that the records were placed in the hands of the Kaiser, if good fortune favored him and the "Deutschland" gets safely back to Bremen.

This is one reason why every German in Norfolk said a little prayer as she cleared the capes for deep water.

The Colonial Music Shop, recently opened in Freeport, Ill., by A. G. Crockett, handles a full line of Edison phonographs in addition to pianos.

**SALISBURY CO. OPENS STORE**

SALISBURY, N. C., August 7.—The Salisbury Music & Supply Co. recently opened a new store at 102 Dock street for the purpose of featuring the Victor line of talking machines and records, over 350 different selections being carried in stock. Several soundproof booths, furnished in wicker, add to the attractiveness of the store. The owners of the store are W. C. Day, Jr., of Danville, Va., and G. P. Stanley, of Parkton, N. C., both of whom have had wide experience in the talking machine field.

**A VERSATILE "TALKER" DEALER**

Chas. L. Gordon, Jamaica, N. Y., a live Victor dealer of that city, not only finds time to operate a band and orchestra which is known as Gordon's Red Uniform Band, but he is a composer of no mean distinction. His latest success is "Peace and Liberty," a march that is being played by a number of bands in the eastern section of the country.

**THE PHONOGRAPHIC TOP**

The phonographic top is the latest novelty based on the principle of sound production found in all talking machines. The top is a metal disc with seven circles, of graduated size, fashioned of pin-point dots upon it, each circle representing the note in the scale of C natural. To play a tune on it, the top is spun so that the disc revolves rapidly, and the dots flash around so quickly that they have the appearance of a continuous line. With the point of a paper cone the different lines are touched, and the notes of popular airs can thus be picked out.

**SOME PLACE TO VACATIONIZE**

Joseph Honig, advertising manager of the Doehler Die Casting Corporation, Brooklyn, N. Y., is spending his vacation at Lake Chargoggagoggmanchaugagoggchaubunagoggamaug, Webster, Mass. Mrs. Honig accompanies him. Mr. Honig submits this lake name as a new talking machine name suggestion.

**A Good Filing Cabinet for the Price of a Good Record!**  
**"Lundstrom" Standard Sectional Record Cabinet**

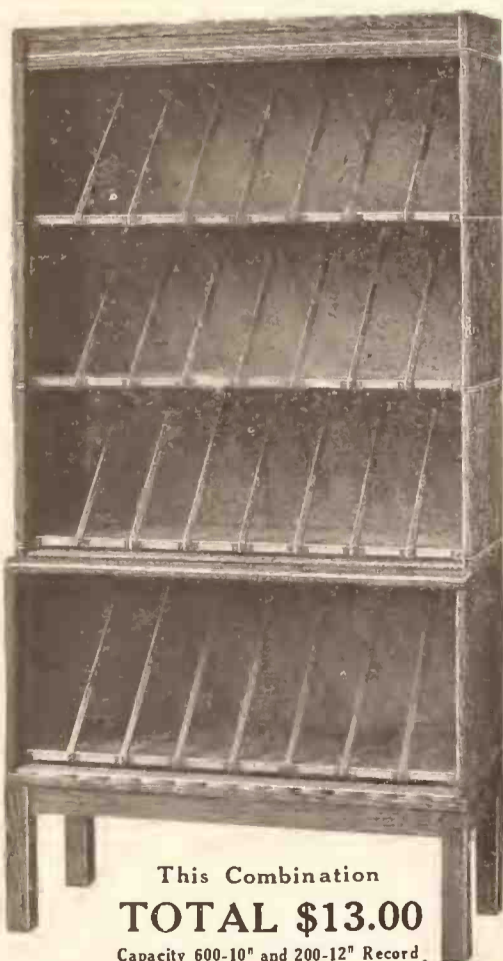

- TOP ← \$1.50 A practical, inexpensive, convenient cabinet for dealers; made on the sectional principle, affording the following advantages:
- 10" REC. ← SECTION \$1.75 It grows with your requirements: You first purchase just the number of sections you actually need for your present requirements; as you need more space, add more sections.
- 10" REC. ← SECTION \$1.75 Adapted to any space: As many sections as desired may be placed in a stack; as many stacks may be used side by side as wall space will permit.
- 10" REC. ← SECTION \$1.75 Neat in appearance: No empty shelves; no overcrowding. Case always complete, yet always capable of additional expansion.
- 10" REC. ← SECTION \$1.75 Carefully made and beautifully finished in plain oak, golden finish. Metal strips for partitions, with label holder under each compartment; eight compartments in each section.
- 10" REC. ← SECTION \$1.75 Made in two sizes; to hold 10-inch and 12-inch records. Each section holds 200 records (100 Edison records.) Stack may be made up with all sections of the same size; or sections for 10-inch records may be used above sections for 12-inch records by means of a reducing section as shown in accompanying illustration.
- REDUCING ← SECTION \$1.75 Price per section for 10-inch records **\$1.75**
- 12" REC. ← SECTION \$2.25 Price per section for 12-inch records **\$2.25**
- 12" REC. ← SECTION \$2.25 10-inch top section, \$1.50; base, \$1.75  
12-inch top section, \$2.00; base, \$2.25
- ← BASE \$2.25 Reducing section, for use when 10-inch and 12-inch sections are used in same stack, \$1.75.

This Combination  
**TOTAL \$13.00**  
Capacity 600-10" and 200-12" Record,  
**On Approval—Freight Paid**

**The C. J. Lundstrom Mfg. Co.**  
LITTLE FALLS, N. Y.  
Branch Office: Flatiron Bldg., New York City  
Fifteen Years' Experience Making High Grade Filing Cabinets and Bookcases



Send for our new illustrated circular, No. 60.

# THE TRADE IN PHILADELPHIA AND LOCALITY

PHILADELPHIA, PA., August 6.—The talking machine business in Philadelphia during July was everything that the dealers could hope for, so far as the public is concerned, and nearly everything they had hoped for from the manufacturers, who were not able to keep the trade properly supplied and yet they did better than during some of the previous months of the year. Whether it was the Victor, the Columbia or the Edison dealers, all of them report that their business has been only limited by the amount of stock they were able to secure in the way of machines, but in records most of them had little about which they could complain. They are beginning to understand the trade and are sending in their orders for records in such a way that many of the big firms here have been able to supply the demand almost to the extent of 100 per cent.

## Death of John B. Miller

Death has entered the ranks of the prominent local talking machine dealers in the passing away of John Bremer Miller on Sunday, July 30 at 6.30 p. m. Mr. Miller had been treasurer of the Penn Phonograph Co. for a number of years, and was one of the best known and best liked of the men in the local trade. The wide esteem in which he was held was shown in the many messages of regret received by the company and by the large attendance at his funeral.

Mr. Miller had not been in the best of health for some time and concluded on taking an automobile trip through New England, accompanied by Mrs. Miller. They were on their homeward trip when he was taken with a chill while riding near New London, Conn., towards evening. He was feeling better the following morning and decided to resume the journey home in his machine. He was extremely ill all the way until this city was reached on Saturday last, when a consultation of physicians was held at his home, and the doctors pronounced him critically ill and advised that he be removed at once to a hospital. This was done but he only survived until Sunday. Mr. Miller was buried from his home, 705 Kenilworth avenue, Oak Lane, on Wednesday afternoon at 3 o'clock, and is survived by Mrs. Miller.

Mr. Miller began his business career when a

young man, by connecting himself with the William H. Horstmann Co., now at Fifth and Cherry streets. Later he was connected with the firm of Partridge & Richardson, department store, at Eighth & Chestnut streets, where he was in charge of the wholesale department. After that he went into business for himself at 1004 Market street. He closed out his interest in that business in 1898, when the Penn Phonograph Co. was established, and became treasurer of that company, a position he has held ever since.

Mr. Miller was fifty-three years of age, and a prominent member of the Rotary Club, the Manufacturers' Club, the Odd Fellows and also the Masonic Fraternity. He took an active interest in the Lutheran Church at Oak Lane. Among those who attended the funeral were F. K. Dolbeer, George D. Ornstein, H. C. Brown and W. B. Fulghun, representing the Victor Co., and the local jobbers were well represented as well as a number of out-of-town retailers.

As the Penn Phonograph Co. is a stock company, Mr. Miller's death will cause no change in the firm. H. F. Miller, the secretary of the company, who was no relative of the deceased, was absent on an automobile trip at the time of the death. He left this city on Saturday, July 29, and as he left no direct address at which he could be reached, he did not hear of his partner's death until after the funeral, as the firm was unable to locate him.

## Report an Active Business

The Penn Co. report that its business was most excellent in July and that the increase was simply remarkable. This concern is experiencing the same difficulty in getting machines that it had for several months past and has been unable to accumulate any stock whatever for its fall trade, machines going out as fast as they are being received.

## Vacations Under Way with Blake & Burkhart

Blake & Burkhart, the most prominent firm handling the Edison machine in this city, report that their business in July has been quite satisfactory for that month. They have been able to fill up their stock of records in very good shape, and machines have also been coming through in a satisfactory way. Herbert E.

Blake is away on his vacation at the present time, which he is spending in taking automobile trips to every section from his country home near Llanarch, Pa. G. G. Blake, Jr., one of the salesmen, is also away on his vacation, which he is spending at Buffalo, N. Y. Irvin H. Burkhart will leave for a two weeks' stay at Ocean City, Md., on Monday of next week.

## A. H. Bates Takes Charge

A. H. Bates has been made the head of the talking machine department at the Wanamaker store. He is a very efficient man and they are planning big things for the coming season.

## Buehn Doubles Last Year's Business

The Louis Buehn Co. reports that it has doubled last year's business for July and a very large percentage of this increase was in the record department. Mr. Buehn says "the sale of records with us has kept up wonderfully well. Records and machines are coming in in a fairly decent way, and in a sufficient quantity. We have unfilled orders now for a large number of machines, and we hope to be able to meet all demands that may be made upon us. Everything points to the best season we have ever had."

## Phenomenal Columbia Business

Manager Eckhardt, of the Pennsylvania Talking Machine Co., reports that the company's business has been phenomenal, and that it is not a case of business itself, but a case of merchandise. July showed the average percentage of increase of previous months, and on August the first the firm had back orders and unfilled orders the largest in its history.

Mr. Eckhardt had hoped to remain away during the entire month of July, but he has decided to merely spend as much time as possible with his family at the Marlborough-Blenheim, Atlantic City, and go back and forward from his office several times a week. He says his firm is, for the first time in a great many months, in receipt of shipments of the fifteen, twenty-five and thirty-five dollar machines, and that it is a real pleasure to renew their acquaintance with this particular type.

## INCREASE UNIT CO. FACTORY FORCE

PHILADELPHIA, PA., August 8.—So brisk is business with the Unit Construction Co., Thirty-first and Chestnut streets, this city, makers of Unico booths, that a doubling of the force was necessary, and the plant is working day and night.

A number of big deals were recently closed, involving thousands of dollars, for special installations, while the smaller orders comprising one or more separate booths have practically trebled.

Inasmuch as the Unit Construction Co. makes a specialty of prompt shipments, it is obliged to carry a tremendous amount of stock on hand, this service being rendered without charge to any dealer.

## CARING FOR SOLDIERS' FAMILIES

CAMDEN, N. J., July 31.—The Victor Talking Machine Co., which has a number of employes away at the front with the army, is looking after the dependents of those men, and will continue to do so as long as they are away in the service. In addition to giving the men full salaries while they are away, arrangements have been made to see that the families of the men are not in want. The Victor Co. is co-operating with a special committee appointed by the City Council in this work.

A new structure to be known as the Edison Building, is rapidly nearing completion on South Salina street, Syracuse, N. Y. It will be occupied by Frank E. Bolway & Son, distributors of the Edison Diamond Disc phonograph, as soon as it is finished.

18 Years of Service  
is back of every  
Penn Shipment of  
Victor Victrolas

*"We know how to do it"*

PENN PHONOGRAPH CO.  
PHILADELPHIA

**DEEP STUFF** is subway building. The engineers puzzle over plans and blueprints for many moons before the work is completed. But at last it is **BUILT**.

Service is never **BUILT**. No matter if Buehn Victor Service is the best today, we want it the best **TOMORROW**, and the next day. It is this "keeping everlastingly at it" policy that **WINS**.

What you want is **DELIVERIES**. You want your record business to be **PROFITABLE**. You want goods when you want them, today, tomorrow and the next day. Quick service followed by a big rest is a flash in the pan.

Buehn Service delivers. It delivers consistently, quietly, and permanently. It is the kind of service that successful dealers must have in order to be successful.

THE  
**LOUIS BUEHN**  
COMPANY

**PHILADELPHIA'S**  
Exclusive Wholesale  
**VICTOR DISTRIBUTORS**



FIT ANY CABINET  
Vertical or Horizontal Filing

**“THE INDEXO”**  
Trade Mark Reg.

**PHONO RECORD HOLDER**

makes a man proud of his records, because every title in his collection can be seen when they are in his cabinet. He will therefore be a good record buyer.

Every Indexo file is cloth bound all around to stand the hardest usage and has an artistic design on front and back. 10 and 12 inch sizes. Put up for retailing one dozen to a carton—one gross to a case.

Order now to make sure of supply.  
Sample and prices on application.

**HENRY ROSENBERG**

Sole Manufacturer

14-16 WOOSTER ST.,

NEW YORK

**READY FOR FALL RUSH IN BALTIMORE**

Talking Machine Dealers of That City Prepared to Handle Unusual Volume of Business During Coming Months—New Dealers Enter the Field—Warm Weather Business Good

BALTIMORE, Md., August 4.—Baltimore dealers are preparing to handle a big fall rush. Almost all of them are stocking their stores as fast as they can. The retailers, with but few exceptions, report that they are doing excellent business considering the fact that a great many people are out of the city. Record business also is holding up well.

The Victrola department recently opened by the Mann Piano Co., of which Charles R. Stram is manager, is making excellent progress. Mr. Mann has just had a large sign placed in front of his store and this attracts a great deal of attention.

The talking machine department of the Hub, a large department store, has been removed from the main building to Charles and Fayette street, the house formerly occupied by the Sanders & Stayman Co. The firm handles the Edison and Columbia lines. The building has been greatly improved and is one of the finest in this section. The department is in conjunction with a new piano department just opened. There are six booths on the first floor and the entire interior is finished in white. W. E. Collins is in charge of the talking machine department. C. B. Noon is head of the new store.

Failure to secure sufficient machines to meet the demand is still the complaint coming from the distributors. Most of the Victor dealers are hard after the distributors in their efforts to get their stock well up. The distributors are doing all they can to accommodate them, but they are having a trying time.

A. J. Heath, in charge of the Columbia headquarters here, is overjoyed the way business keeps up. "It is truly wonderful," he said, "and things are just going great with us. Prospects were never better. The dealers continue to stock up and are taking all of the goods they can get their hands on. All appear to be sure that the coming fall is going to be a record breaker and they want to have all the ammunition in their line. In other words, the preparedness in the air has spread to the business world."

Jesse Rosenstein, the Pathé distributor, announces that he has just signed up the Rominger Furniture Co., Winston-Salem, N. C., and Amberg & Jordan, Inc., 406 to 408 North Eutaw street, one of the large furniture houses of Baltimore. Mr. Rosenstein expects to announce some additional distributors very shortly. He reports business very good.

The shortage of machines is still handicapping H. R. Eisenbrandt Sons, Inc., Victor distributors. Henry Eisenbrandt, who has charge of the Victrola department, says that he would have no trouble whatever in disposing of far more machines than he is able to get possession of. The same shortage is reported by Cohen

& Hughes, also local distributors of the Victor line.

The higher priced machines are having the call with E. F. Droop & Sons Co., also distributors of the Victor Co. machines and records. W. C. Roberts, manager of this house, is away on his vacation at present. The same old shortage is reported.

Although the weather is very warm the sales of the Aeolian-Vocalion, which is handled in this section by the Sanders & Stayman Co., holds up well. W. B. Turlington, manager of the house, says no complaint whatever can be made upon the way the machines are selling. The demand in this line also runs toward the higher prices. The house also handles the Victor and Columbia machines.

L. K. Scott, formerly with the Reid & Hughes Co., of Waterbury, Conn., is the new manager of the Victrola department of Stewart & Co., one of the largest department stores in the city. Mr. Scott, who recently came to this city, is much pleased with the outlook. He has started to make plans for the Fall rush and is getting in a good supply of machines. Mr. Scott has added E. M. Ogilvie, formerly with the Sonora Co., in New York, to his present sales force. A live campaign is planned.

Preparations for the fall trade with the Victrola department of William Knabe & Co., which is now under the management of Henry T. Kennedy, who has taken the place of Milton Boucher, promoted to the piano department.

**TELEPHONES ORDERS FROM COAST**

SAN FRANCISCO, CAL., August 3.—The Stern Talking Machine Corp., 1085 Market street, Pacific Coast distributors of Rex phonographs and records, has been closing a large business. A few weeks ago Frederick Stern, president of the company, decided to call up the Rex plant at Wilmington, Del., on the long distance telephone in order to arrange for additional shipments of machines and records. He ordered two carloads of merchandise for shipment this month, and also inquired regarding another carload which had been somewhat delayed in transit. This telephone call from the Coast to the East is a fair indication of the Stern Co.'s energetic sales policies.

**PLAUT-CADDEN CO. RECITALS**

NORWICH, CONN., August 8.—The Plaut-Cadden Co., of this city, Victor dealers, have been receiving considerable notice in the local newspapers by reason of the success they have achieved with Victor recitals. This company has made a specialty of giving informal concerts at frequent intervals, and aside from the increased sales which this publicity has produced, these recitals have served to make the Plaut-Cadden store a Mecca for local music lovers.

Eugene Krone has opened a new and exclusive Diamond Disc store in Bryan, O.

**Deliver Your Talking Machines  
in LANSING Khaki Covers**

Preparedness is the cry throughout the Country and an order placed now is a move in the right direction by getting ready for the coming Season's business.

All materials are of High Grade—the covers are heavily padded and quilted and properly manufactured—the Patent Buckle that is used is a necessity for Safely handling these expensive instruments.

**LANSING**  
The Pioneer Khaki Moving Cover Mfr.

They afford perfect protection from the Weather—finger prints—scratches and all other blemishes.

Use the Lansing Khaki Moving Cover and save money.

“BEST BY TEST” IS THE LANSING SLOGAN.

**E. H. LANSING,** 611 WASHINGTON STREET,  
BOSTON, MASS.



**150 NEW DEALERS IN THREE MONTHS**

G. Sommers & Co., St. Paul, Minn., Win Quick Success as Jobbers of the Pathé Phonographs Throughout Northwestern Territory

ST. PAUL, MINN., August 1.—C. E. Gore, traveling representative for the Pathé Frères Phonograph Co., New York, left this city this week after spending three weeks with G. Sommers & Co., Pathé distributors for this territory. Mr. Gore's time was well-spent in this city, as he assisted G. Sommers & Co. in putting their stock in shape, and also gave them valuable help in organizing the efficient sales staff which is now visiting the trade.

G. Sommers & Co. have only been Pathé distributors since the first of May, but in this very short time have signed up 150 dealers to handle the Pathé line. Their territory reaches out to Spokane, covering the Northwest to that city, and fifteen salesmen are spending all their time co-operating with the company's Pathé dealers in this section.

Before leaving St. Paul, G. Sommers & Co. gave Mr. Gore an order aggregating \$125,000 worth of Pathephones and Pathé discs, and according to their present plans and the aggressiveness of their sales campaign, they will sell \$500,000 worth of Pathé goods before the first of the year. L. T. Ware, who is in charge of this division of the Sommers business, is a keen and aggressive merchandising expert, and his enthusiasm regarding the possibilities of the Pathé line is based on years of experience and judgment which are reflected in the success his company has already achieved in the Pathé goods.

Mr. Gore's destination after leaving St. Paul is Memphis, Tenn., where he will render similar co-operation to the Armstrong Furniture Co., which only recently arranged to handle the Pathé line as distributors. Mr. Gore is thoroughly versed in all phases of the talking machine industry, and the practicability of his suggestions is evidenced in the splendid sales totals of the Pathé distributors with whom he has worked.

**INCREASING ITS FACTORY CAPACITY**

St. Louis, Mo., August 5.—J. P. Fitzgerald, president of the Mozart Talking Machine Co., states that the company's sales totals this summer have far exceeded all expectations, and as a matter of fact, business the past month or two has resembled the fall and winter season's activities. The company is steadily increasing its factory capacity to cope with its increased business.



C. E. Gore

**SALES POINTERS OF VALUE**

Bearing on Victor Records and Their Use Sent Out by V. W. Moody, of Neal, Clark & Neal, Buffalo—Offers Some Interesting Facts

BUFFALO, N. Y., August 7.—V. W. Moody, manager of Neal, Clark & Neal, Victor distributors, has just sent out to the company's dealers for general distribution a selected list of Victor records for the convenience of those who have not had an opportunity to study the complete Victor catalog.

On the last page Mr. Moody asks a number of pertinent questions, under the heading "Do You Know?" "That your Victrola should operate at a speed of seventy-six revolutions per minute? That the governor 'friction pads' must be oiled monthly? That the sound box gaskets must be live rubber? That your Victrola must not vary in speed the slightest? That in a high soprano note there are 3,000 vibrations per second? That if your motor drags for one-half of 60/76 of a second that 1,500 of these soprano vibrations will be flat? That your reproducing point (needle) travels over approximately 100 yards of reproducing surface with each twelve-inch record played?"

**OUTING OF TALKING MACHINE MEN**

Talking Machine Dealers' Association of Buffalo to Hold Annual Picnic This Month

BUFFALO, N. Y., August 1.—The Talking Machine Dealers' Association of Buffalo, one of the most influential organizations of its kind in the country, is completing arrangements for the annual outing to be held late in August. Present plans point toward the affair being staged at Crystal Beach, a lake resort on the Canadian shore. F. E. Bruehl, of the Neal, Clark & Neal Victrola department is the chief spirit working toward the success of the big event.

**ENJOY HARRY LAUDER'S RECORD**

At a dinner given last month by the Chamber of Commerce, of Odgensburg, N. Y., the members and guests, among whom was Chas. M. Tait, of Gouverneur, N. Y., had the pleasure of listening to a telephone conversation between Odgensburg and San Francisco. One of the interesting features of the program was hearing Harry Lauder's Victor record, "I Love a Lassie," played on a Victrola in San Francisco. Mr. Tait states that every word was astonishingly clear and distinct, and that Harry Lauder's Scotch "burr" was as distinct as though the Victrola was in the very room in which they were sitting. The program closed with "The Star-Spangled Banner" played on the Victrola.

R. E. Babylon has purchased an interest in the Dillon Bros. talking machine factory at Piqua, O., which will be enlarged by the addition of a new building and the installation of new machinery.

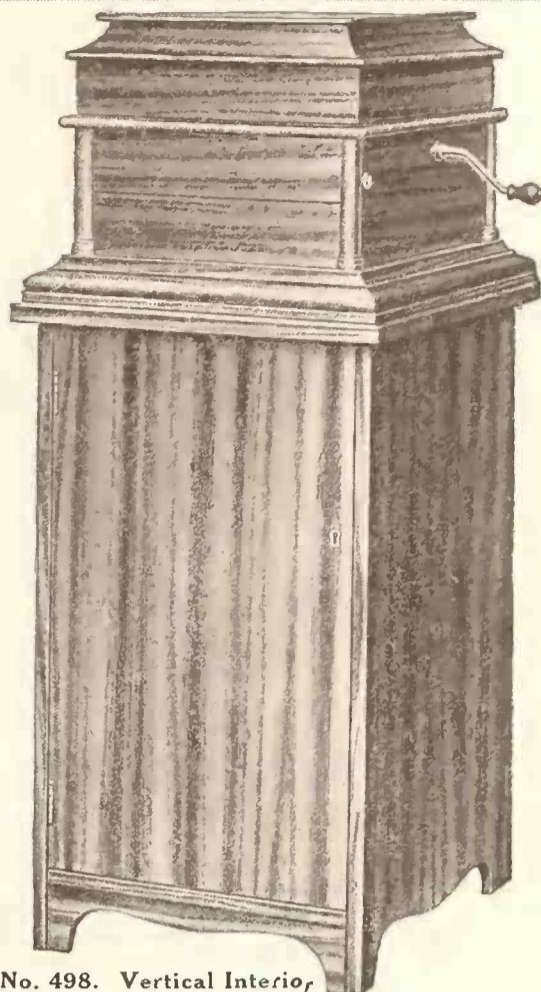

No. 498. Vertical Interior For Columbia "Favorite" Height, 32 in. Width, 19 in. Depth, 22 in. Holds 240 records. Mahogany Front—Golden Quartered Oak Front Average weight, crated, 80 pounds. [If horizontal shelving is desired, order No. 1498.] [When felt interior is wanted, order No. 498F.]



**For Records**

play a leading part in the sale of a talking machine outfit. This is true because a machine and a library of records *without* a Udell Record Cabinet are *not* complete.

Put it up to your customer and ask him where he is going to file his records. Of course, people buy what they see—so have several in your store. You not only get the profit on the cabinet but you are making a better record buyer. The importance of that cannot be overstated. A better record buyer because he takes some pride in the care and filing of his records. He knows just what he has because of the system used in filing.

The large capacity of a Udell Record Cabinet makes a consumer want to fill it up.

Yes, it's a mighty good proposition for you to push Udell cabinets.

You can get pictures and prices by writing to

**The Udell Works**  
1204 West 28th Street  
Indianapolis, Ind.

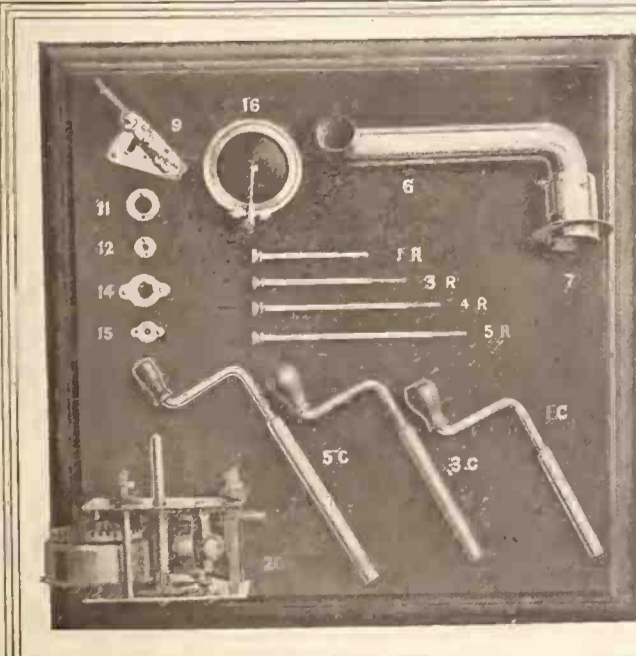

An opportunity to secure  
**MOTORS**  
SOUND BOXES—TONE ARMS  
at extremely low prices

MOTORS	
1 Bbl. (about 125 motors)	at \$1.00 per motor
1,000 "	.95 " "
5,000 "	.90 " "
SOUND BOXES	TONE ARMS
100 lots---.60 each	100 lots---.60 each
1,000 " ---.50 "	1,000 " ---.50 "

**WONDER TALKING MACHINE CO.**  
113-119 Fourth Ave., (12th St.) New York  
Telephone, Stuyvesant 1666, 1667, 1668



Hall

# Offer This Newest Service to Our Dealers ~ ~ ~ The Full Line of Pathéphones and Pathé Disc Records

## Concerning Pathé Quality



WE have chosen Pathé products because they have an international reputation; because they are reliable; because dealers can sell them with the knowledge that customers will stay satisfied.

We chose the Pathéphone because it has a "Violin" Sound Chamber of resonant wood that adds warmth and mellowness to tone. Because it plays with a polished Sapphire Ball that never has to be changed and never scratches records (like sharp metal needles).

We chose Pathé Discs because they reproduce more truly. Because they are more durable, showing no signs of wear after years of use. Because they are cheaper—All Pathé records from dance music to grand opera are double-disc. A single price pays for two selections. Because Pathé Discs reproduce not only the voices of singers who are enjoying triumphs in America, but also the voices of famous European artists who have never sung in this country. Finally, we chose Pathé Discs because the indications are becoming clearer and clearer daily that the public will demand Pathé records, no matter what make of machine they own.

## Concerning Our Financial Service

WE are prepared to back up Pathé products and to stand behind our dealers with the strongest kind of service. We don't mean just merchandising service. Everybody is doing that now, more or less. We mean **Financial Service**.

**We will cash your installment phonograph paper! We will let you buy new stock on the strength of your customer's promise to pay!** This means that your business can grow from the start. You don't have to wait for the cash to come in.

If you are the kind that likes to grasp success more than to dream about it, you will ask our Phonograph Division **today** about our Financial service.

# Davis Piano Company

(Established 1839)

MONOGRAPH DIVISION

General Offices, 18 East 42nd St., New York



**Al Jolson--the biggest money maker in the popular record field, and an exclusive Columbia artist. New records by Jolson in the September list.**

*(Write for "Music Money," a book "full of meat" for those dealers interested in quick and frequent turnover of capital.)*

**Columbia Graphophone Co.  
Woolworth Building, New York**

**MILLION POUNDS OF SPRING STEEL**

**Enormous Supply of That Important Material for Talking Machine Motor Manufacture Now on Hand at Otto Heineman Co., Factory**

Five hundred tons, one million pounds of spring steel, for use in the manufacturing of Heineman motors are now on hand, and are



A Small Portion of the Million Pounds being utilized in the production of these well-known motors.

Even in ordinary times, this vast amount of spring steel would attract more than passing

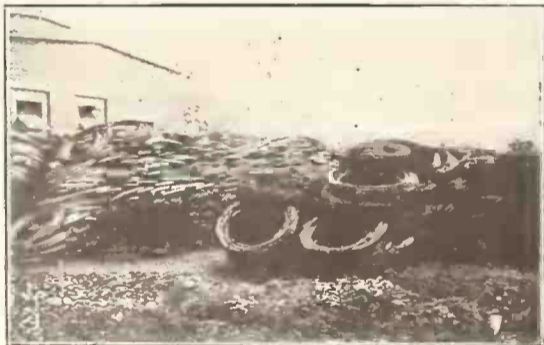

One View of the Spring Steel

interest, but with the present condition of the steel market, and the extreme difficulty experienced by manufacturers in all lines to secure sufficient steel for their daily or weekly re-

quirements, this amount of spring steel assumes imposing proportions.

Otto Heineman, president of the Otto Heineman Phonograph Supply Co., is a firm believer in the doctrine of "preparedness" as applied to commercial success, and as soon as he realized that raw materials were becoming scarcer day by day, made his plans accordingly, and instructed his purchasing agents to spare no efforts to secure an adequate supply of that all important factor in motor production—spring steel.

In pursuance of these instructions orders were placed aggregating considerably more than 500 tons, and although the price was far in advance of anything previously paid for spring steel, Mr. Heineman approved the orders so that his patrons might receive their motor shipments at the earliest possible moment regardless of the expense or inconveniences involved.

The first portion of this vast order was received some time ago, and shipments have been received daily, until at the present time there are one million pounds on hand. All of this steel is subjected to the severest possible tests, and only the very highest grade of product is O.K.'d for use in the Heineman motors.

As soon as this spring steel is approved by the Heineman factory experts it is put in work, and extreme care is taken that the steel stands up perfectly under every process. "Quality" is the keynote of the Heineman factory policy, and no matter how many motors are on order, Mr. Heineman does not permit the slightest deviation from the quality dictates which have guided his company in its remarkably successful career.

A faint idea of the tremendous volume of spring steel comprising one million pounds may be gleaned from the accompanying photographs, although these pictures show but a very small portion of the 500 tons. It is a tribute to the popularity of Heineman motors that even this vast amount of spring steel will suffice but a very short while, as the Otto Heinemann Co.

has received some huge orders the last few months which will necessitate working the factory to capacity and overtime for a long time to come.

**BELIEVES IN AN OUTDOOR LIFE**

**F. P. Oliver Snapped After Eighteen Holes of Golf With Francis Wilson**

Fred P. Oliver, the active vice-president and general manager of the Blackman Talking Ma-



F. P. Oliver and Francis Wilson chine Co., New York, Victor distributor, is a firm believer in the benefits to be derived from an active outdoor life. He is an ardent golfer and has even made his appearance on the "diamond" as a member of the Blackman Talking Machine Co.'s baseball nine. In the accompanying picture, Mr. Oliver "is taking it easy" with Francis Wilson, prominent theatrical star, at the latter's country home, "The Hill," at Lake Mahopac, N. Y. Messrs. Oliver and Wilson just finished eighteen holes when this photograph was snapped by J. N. Blackman, president of the Blackman Talking Machine Co., who was also spending a few days at Lake Mahopac.

**Dealers Who Believe in Efficiency and Who Want—**

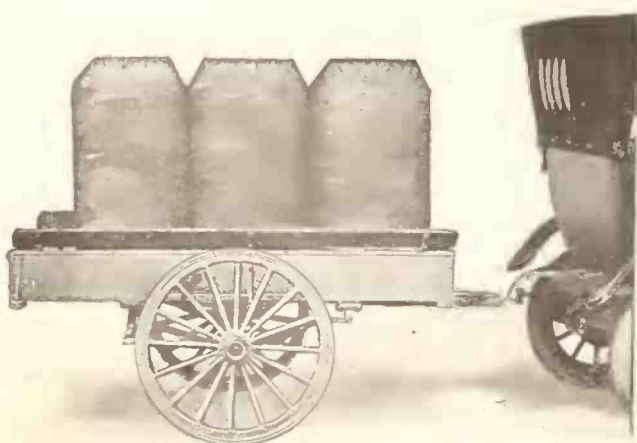

This Model holds 3 Victrolas or 3 similar-sized machines. Also easily carries 1 piano.

To Secure Maximum Utility From an Automobile Should Get

**THE DEKALB TRAILER**

*One of these attached to any make of automobile will completely solve your delivery and receiving problems*

Length, 7 ft.; width, 40 in.; sides 8 in. deep. Solid steel axle, hickory wheels, with either steel or rubber tires. Best quality steel springs. Painted auto black and equipped with draw bar that is quickly attached to any car. Weight, 400 lbs. Easy running and easily handled.

Send a postal for details. It's certainly worth your 'business' while

**DEKALB WAGON COMPANY**

DeKalb, Illinois

**BUILDING UP RECORD BUSINESS**

Some Live Facts and Hints Offered by the Stewart Talking Machine Co., Indianapolis, to a Dealer Whose Record Sales Were Not What They Should Be—Excellent Suggestions

The Stewart Talking Machine Co., Indianapolis, Ind., Victor distributor, sent out a most interesting letter some time ago in response to a letter from a Victor dealer who had written that his record business was only 14 per cent. of his total. This letter, reading as follows, is well worth the careful attention of every talking machine dealer:

"Your recent letter has been considered with much interest, and we have spent a considerable length of time in looking up material for a complete answer. We find that your record orders for the last six months show an advance over previous accounts. You are to be congratulated on that. And you are not to be entirely held at fault because your record business is not greater. Yet it's certain that the record business should be much more than 14 per cent. of the total. They should equal the machine orders. You have done splendid work in placing Victrolas, but you have overlooked vast possibilities for enlarging your record business. We should have told you so sooner.

"At the present time it is possible to get from the Victor factory records in almost numberless quantities—a pleasant situation for you when machines are so hard to obtain. And it is equally as pleasant for us.

"There are several suggestions that might be followed toward the increase of your record business.

"One dealer delighted us with the news that he never hears a customer ask for 'I Hear You Calling Me' without suggesting and, if such is in order, playing three or four other McCormack records. If this dealer does not have 'Cecile' on his shelf he suggests 'Millicent' or any other good waltz record, fearing that in nine cases out of ten a customer will not come back for a certain record if it is not to be had when wanted. A keying system that classifies waltzes, arias, violin solos, etc., under a code sign, enables him to pick out similar records quickly. He does not call this substitution but restitution—saving an order! He is a dealer who sends out great quantities of records on twenty-four hours' approval. For it's an active stimulant to his customers' record appetites—the more they hear, the more they want. He is the dealer who writes a breezy letter with every monthly list of records sent out on his mailing list and who calls by 'phone all customers whom he thinks might be interested in special records. And he is the very same dealer who is profiting and profiting and realizing profit on his record department.

"Another dealer makes a practice of giving monthly recitals, selecting the headliners of each record list and inviting home talent to assist—by this latter feature attracting more local interest. He says pleasant service in the store brings better results than any amount of "record-on-approval" bother.

"But one other man comes forward with a plan for boosting record business which should commend itself to your attention through its uniqueness.

"He employed a young man instructed in the mechanical workings of a Victrola, to make regular tours of inspection among all the local owners of Victor machines, testing the motors to correct jumping, to see if they make seventy-eight revolutions per minute, to see if the diaphragm is at proper tension to bring out roundly the high tones of certain instrumental records he might play (for instance, Kreisler's 'Serenade Espagnole') and to see if the sound box is properly adjusted to produce powerful vocal records such as Caruso's 'Celeste Aida' without 'blasting.' Upon finishing each inspection the young man might play a few other good numbers and leave behind a list of the latest records.

"When the man of the house gets home at night and discovers that his Victrola has been improved he will want to hear for himself. The wife and children will recall the beautiful songs and instrumental selections the young man played, will discover the list of new ones—and there you are. Following the natural consequences still further, this dealer sees neighbors and non-owners of Victrolas trooping

# NEW YORK CITY

## S. B. Davega Co.

Est. 32 years 831 BROADWAY

SERVICE

SERVICE

SERVICE

RECORDS

RECORDS

RECORDS

## Victor-Victrolas

*Send for Price List of Accessories***IMPORTANT ANNOUNCEMENT IN NEXT ISSUE**

in to hear new records on the improved instruments and going home with the "buy-it-now" instinct hard working in their minds.

"Familiarize your customers with the opera, says another retailer. Lead them into the story of an otherwise bewildering maze of music, and speak in plain United States words so that they may feel Lucia di Lammermoor to have been no one but little Lucy from the old Scotch town of Lammermoor—as, indeed, she was. Let them know that the English meaning of 'Cavalleria Rusticana' is 'Rustic Chivalry' and that the plot is based on a situation that has popped up in human events since time out of mind—that of a woman, well married, making up to a former lover. Show your customers clearly that grand opera is simply a magnifying glass which intensifies the loves and passions of human beings—although the glass itself may lend a touch of the sublime.

"While you are playing for your friends the remarkable record 88061—Caruso singing 'On with the Play'—explain that the Italian tenor is performing in character of a circus clown 'I Pagliacci'—'The Players'—and is sobbing out his wretchedness over the faithlessness of his wife.

"All this would be bringing them closer to a high embodiment of art—a consequent desire for fuller knowledge—the commencing of a grand opera library—the foundation of a growing record demand. Tell the story! Tell the story! Tell the story!

"The successful pursuit of this plan would call for your advice as to the formation of a customer's record library. You see, the assembling of valuable records should have the same painstaking attention that a book-lover gives to his collections. There are few model libraries that do not have a proportion of light fiction against heavy drama—one balancing the other to a nice degree—but in none does Robert W. Chambers approach in representation Balzac, Victor Hugo or Maupassant; nor is there a lack of Shakespeare or Milton on the shelves. In the same way 'Tipperary' should have a strong counterweight in 'Celeste Aida' and records of similar magnificence.

"Make them know it. 'Victor Book of the Opera' and Voice of the Victor will help you. Grand opera offers a

broad and substantial foundation for a building of record business.

"And here read a few of our words: A record stock increased from well selected numbers is as good as old wheat in the mill—better because it turns oftener. Do not feel that, because records may be easily obtained at the present time it is possible to hold every customer off until his order can be filled here. Did you ever go into a store for a pair of shoes and, when the clerk was unable to fit you, did you agree to wait patiently until the shoe jobber or shoe manufacturer could get a pair made?—A ready stock saves many a sale.

Your record business should equal your machine business.

"You have turned a commendable voltage or energy on Victrola business, but switching a little more current into record lines would liven up the wires for all of us, and set the sparks to jumping in a way that would warm your heart—and ours—and your customers."

**PROTEST GRANTING OF TRADE-MARK**

A protest was filed on July 1, by the Sonora Phonograph Corporation through their attorneys against the granting of a trade-mark to the Pathé Frères Phonograph Co., of Wilmington, Del., on a disc bearing the words "Sapphire Records," the bottom of the plate containing the words, "Made for United States Consumption Only." The Pathé Frères Phonograph Co. has been granted until August 22 to file an answer to the protest of the Sonora Corporation.

The Union Phonograph & Machine Co., of Newark, N. J., was incorporated last week with a capitalization of \$25,000, to deal in talking machines and accessories.

## LEONARD MARKELS

165 William Street

NEW YORK

### First-Class Double-Spring Worm-Gear Motors

The "Markels" Motor is Guaranteed to give *Real Service*  
All Talking Machine Accessories, Sound Boxes, Tone Arms, Etc.

## Prompt Deliveries Guaranteed

UNICO EQUIPMENT

Represents  
Efficiency  
and Economy

CONSTRUCTION  
PATENTED

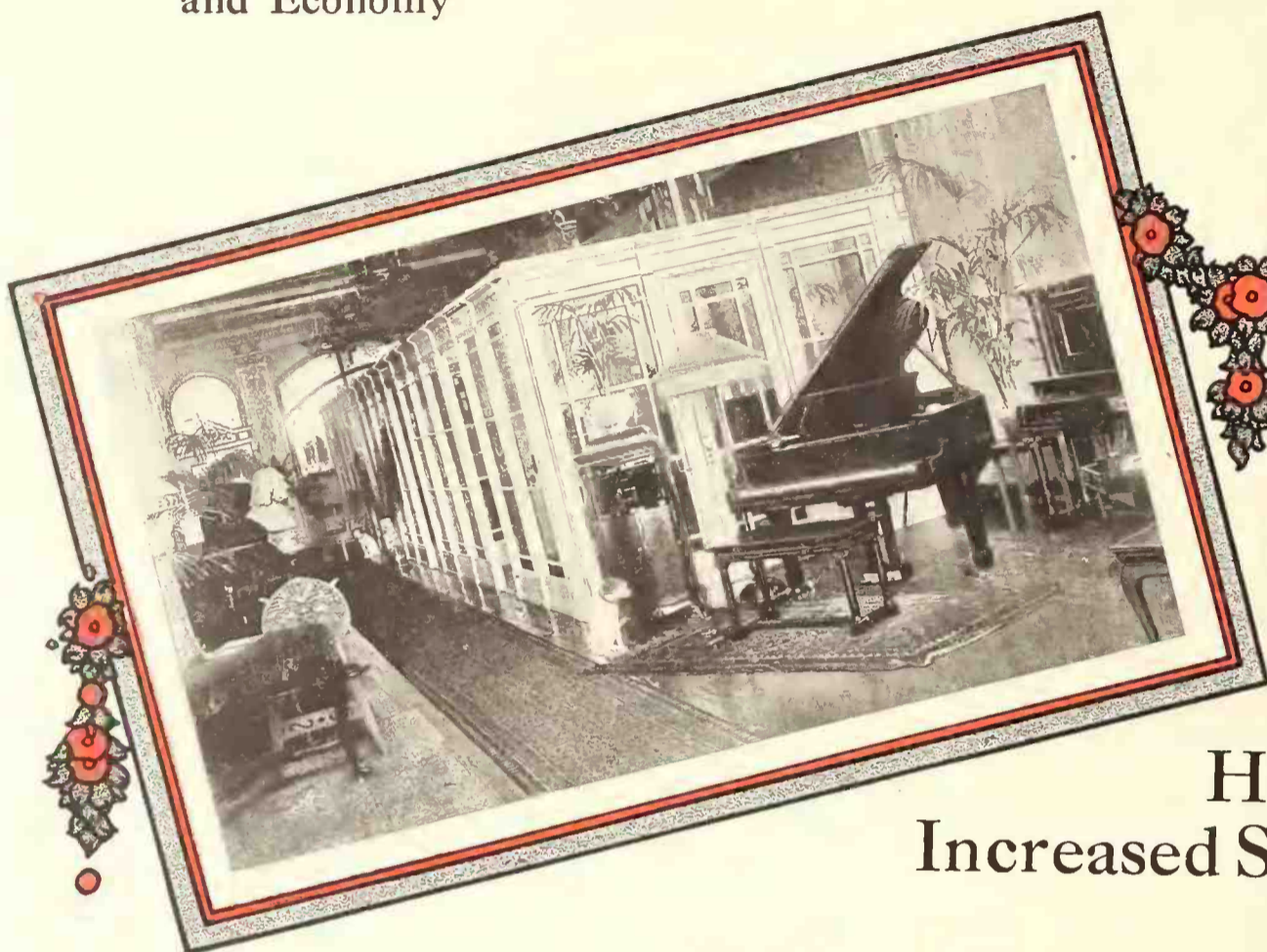

Hundreds of Pro  
Increased Sales and Profit

# The Unico Demon

Order *your* Unico Equipment now

## A Single Room ?

We are shipping one, two and three room installations daily to all sections of the United States.

Any requirement promptly shipped from stock in Standard or Special Finish.

**GAI**  
JOHN L. G.  
**Victo**  
Unit Construction Co.  
31st and Chestnut Sts.  
Philadelphia, Pa.  
Gentlemen:-  
We feel th  
beautiful effect you  
in our store, which e  
It certain  
effect secured and liv  
Convenient  
thank you most heart  
The qual  
you may rest assured  
to our many friends.  
With best  
JLG/BFD

Unico Rooms are shipped Completely  
Exclusive Sound Insu

UNICO COST IS MODERATE  
(Prices Start at \$75)

121-131 SOUTH 31st STREET

We have a Representative in your territory

**Wire**  
THE UNIT CONS

DESIGNS  
PATENTED

UNICO EQUIPMENT

Attracts and  
Holds  
New Trade

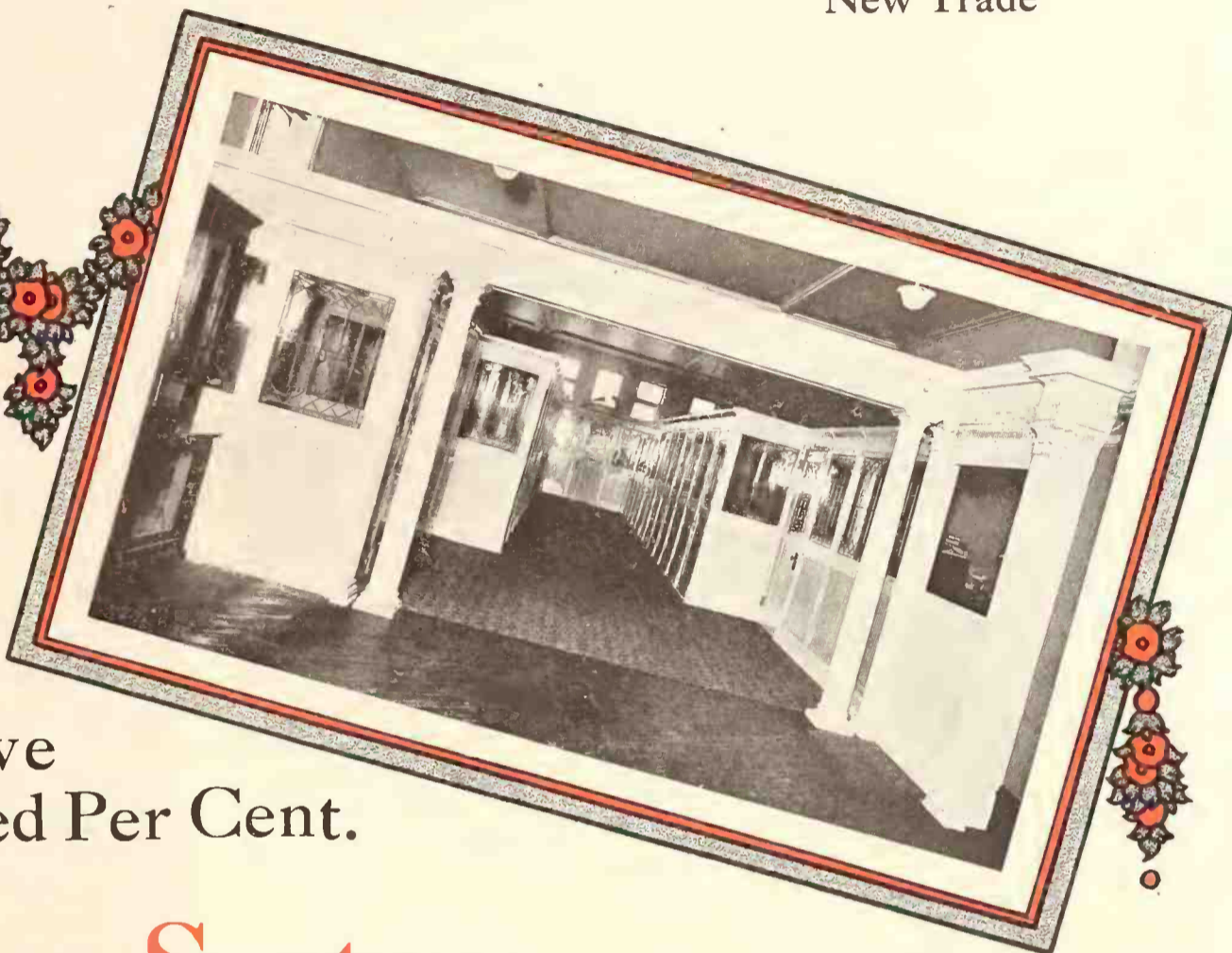

Dealers Have  
One Hundred Per Cent.

# ing Room System

rganize *your* Department over night

## The Largest Department ?

Twelve of the largest Talking Machine Departments in the United States will be equipped by us in the next thirty days.

Ten Exceptional Designs  
(Patented)

Sectional Interlocking Construction  
(Patented)

Finished ready for Quick Installation  
at Proofing Features

UNICO QUALITY INSURES SATISFACTION  
(Over 30% Repeat Orders)

Descriptive Literature on Request

ON COMPANY

PHILADELPHIA, U. S. A.

**INTEREST IN EDUCATIONAL RECORDS**

Dealers Steadily Showing Greater Appreciation of the Opportunities That Lie in the Development of That Line of Business—Good Suggestions from New York Talking Machine Co.

Talking machine dealers throughout the country are realizing more and more the unlimited possibilities which are at their command to develop the sale of educational records. During the past year manufacturers and distributors have joined to impress upon the dealer that the word "Educational" does not necessarily mean that the records listed under that heading are not intended solely for use in the schoolroom, but on the contrary, can be sold for use in the home.

In this connection the following letter recently sent out by A. D. Geissler, vice-president of the New York Talking Machine Co., and the Chicago Talking Machine Co., is worthy of more than passing interest. It reads:

"Did it ever occur to you how many records

there are in our regular educational list which, if brought to the attention of the parents to whom you are selling our regular catalog list, would be eagerly snapped up by them? The Victor Co., at the recent distributors' convention, brought out very forcefully the fact that many parents are in search of indirect methods by which they may educate their children without commanding them to study.

"I thoroughly believe that, if you should devote one room exclusively to the demonstration of educational records, and have one salesman in your force specialize in this work—study it and really become an expert in it, such room would pay you big dividends and at the same time would have the effect of stimulating your other salesmen to similar efforts in suggesting these records to your regular trade.

"This is a scheme which might be systematically and effectively thought out and inaugurated by you. As a suggestion—possibly the enclosed list of educational records would appeal to you as a very good list to take the initiative in." The list enclosed in this letter comprised the following Victor records:

- 31855 National Airs of All Nations. Great Britain, "Rule Britannia"; Austria, "God Preserve the Emperor"; Russia, "God Save the Czar"; France, "Marseillaise"; Italy, "Garibaldi Hymn"; Germany, "Watch on the Rhine"; United States, "Star Spangled Banner." Victor Mixed Chorus 12
- 17104 London Bridge (English). 2. Mulberry Bush. Round and Round the Village. Sousa's Band 10
- 17918 Go to Sleep, My Dusky Baby. Arr. from "Humoresque" (Dvorak), by Frank Rix. Rockin' Time (Gertrude L. Knox). Misses Kline-Baker-Dunlap 10
- 18000 The Hatter (from "Folk Dances of Denmark") (Burchenal). Three Dance (from "Folk Dances of Denmark") (Burchenal)..... 10
- 17163 The Seven Ages of Man (from "As You Like It") (Shakespeare)..... Frank Burbeck 10
- Shylock's Rebuke (from "Merchant of Venice") (Shakespeare)..... Frank Burbeck 10
- 17580 America (Henry Carey)... Victor Military Band 10
- The Red, White and Blue (David T. Shaw). Victor Military Band 10
- 60080 The Toymaker's Shop ("Babes in Toyland") (Herbert)..... Herbert's Orchestra 10
- 55049 Songs of Our Native Birds, No. 1. Catbird; stormy petrel; cardinal redbird; jenny or house wren; loon; red wing blackbird; bobolink; California mountain quail and general conversation of the birds of the marsh. Charles Kellogg 12
- 55049 Songs of Our Native Birds, No. 2. Ringdove; goldfinch (wild canary); wood pewee; blue jay; whip-poor-will; mourning dove; meadow lark; peabody bird (white-throated sparrow); catbird; wood or barn owl; boot owl. Charles Kellogg 12

**LARGE ORDERS FOR DIAPHRAGMS**

James L. Frazee, 30 Church street, New York, manufacturer of "Crystal Edge" diaphragms, returned Monday from a trip to New England, during which he concluded arrangements for purchasing large quantities of raw material in order to adequately handle his fast-growing trade. Mr. Frazee now has a traveling representative in the South, and is making plans for a large fall and winter trade. He states that during the past week or two he has received a number of very large orders for his diaphragms, one order totaling \$12,500.

M. J. Coats, who recently opened a drug store in the new Grace Building, on William street, Little Falls, N. Y., will also carry a line of Edison Diamond Disc phonographs.

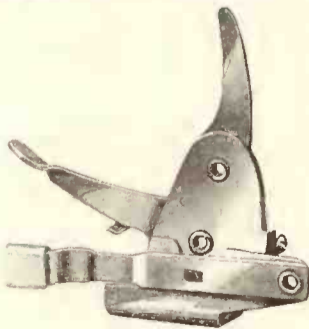

For Talking Machine Manufacturers and Dealers

The Perfect Automatic Brake. Simple construction. Easily attached. No Talking Machine complete without it.

Write for sample and attractive quantity prices.

**PERFECT AUTOMATIC BRAKE CO.**  
Room 400, 425 S. Wabash Ave., Chicago

**SOSS**  
**Invisible Hinges**



Preserve the beauty of well designed and finely finished

Talking Machines  
Music Cabinets  
Pianos  
Player Pianos and Benches

They are made in numerous sizes for these particular purposes.

When you fail to see an unsightly Hinge protruding you know **SOSS** is the answer.

Write to-day for catalogue T.

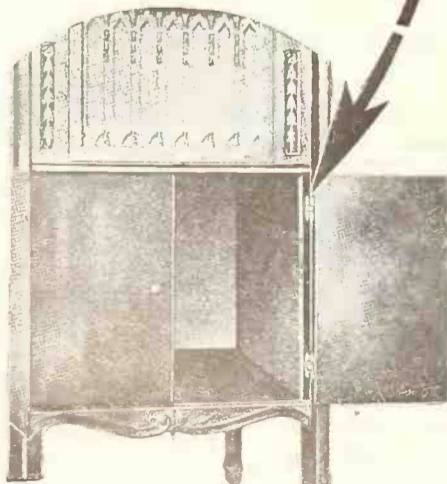

**Soss Manufacturing Co.**

435-443 Atlantic Avenue, Brooklyn, N. Y.

BRANCH OFFICES:

Chicago—160 North Fifth Avenue.

Los Angeles—224 Central Bldg.

San Francisco—164 Hansford Bldg.

Minneapolis—3416 2nd Ave. So.

Detroit—922 David Whitney Bldg.

**A GOOD** needle is essential to the proper production of clear, rich tones. A poor needle will mar the beauty of the finest machine and the finest record. The needle here offered has stood the test of time and has been found to be of superlative value.

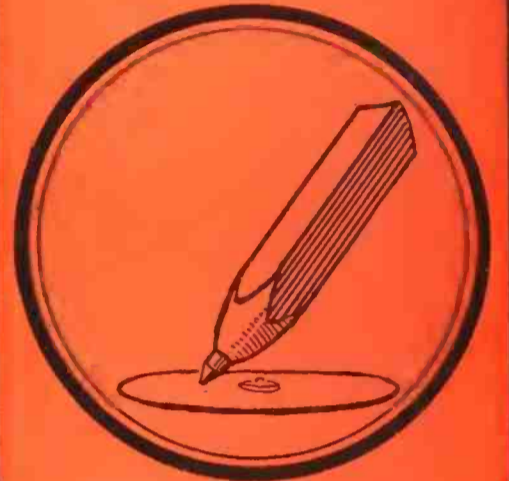

**Sonora**  
*Multi-playing Jewel*  
**Needle**

**FITS** the records exactly preventing wear and reproducing tone values perfectly.

**HARD** and unchanging in form and prolongs the life of the records.

**GIVES** splendid satisfaction for three months of the hardest kind of service. **GUARANTEED** to do this.

**DOES** away with the annoyance of continually changing steel needles.

**SELLS** easily at \$1.00 and affords a good profit to the dealers.

Stock the Sonora Multi-Playing Jewel Needle!

Write today for information and prices

**Sonora Phonograph Corporation**

GEORGE E. BRIGHTSON, President  
Makers of Sonora Phonograph and Sonora Multi-playing Jewel Needle

57 READE STREET NEW YORK



If you have missed the Columbia profits during the last season, you must have done it unwillingly. If you miss them this coming season the amount of them will make a long column on your debit page.

(Write for "Music Money," a book "full of meat" for those dealers interested in quick and frequent turnover of capital.)

Columbia Graphophone Co.  
Woolworth Building, New York



### GREAT EXPANSION OF EDISON PLANT

Present Factories Being Worked Night and Day to Keep Up with Demand and Additional Buildings Are Necessary—A Formal Statement Regarding the Situation

The factories of Thomas A. Edison, Inc., Orange, N. J., for some months past have been taxed to their utmost capacity as a result of the tremendous demand for the New Edison and Edison Re-Creations and it now has become necessary to erect a number of temporary structures in the vicinity of the works in order to provide for additional manufacturing facilities. There recently has been a tremendous increase in Edison sales, an increase that has made necessary the maintenance of large night forces and the carrying on of work in some departments seven days a week. It is to relieve some of this congestion that portions of the permanent buildings that formerly were used for storage purposes are being equipped with machinery and delivered to the purpose of active manufacturing.

A formal statement regarding conditions at the Edison phonograph plants has just been issued. "Business has attained phenomenal proportions," it states, "and the capacity of our present buildings is greatly overtaxed. We have found it necessary to divert former storerooms to active manufacturing purposes and we now are storing large quantities of raw material, as well as much of our finished product, in tempo-

rary structures that have been erected in the vicinity of our plants. Our men are working day and night, also Sundays. We have found it necessary to impose a tremendous burden on every branch of our manufacturing division in order to keep up with the demands made upon us by the sales department.

"Before the New Edison was placed on the market it was foreseen that its introduction would be followed by a strong demand for the instruments and records. It was supposed that ample preparations to fill the requirements of any market that might develop had been made. But the demand has exceeded all expectations and, as a result, we are having difficulty in meeting it. The spirit of Mr. Edison animates the entire organization, however, and, because of this, we do not feel that anything is impossible. By making the most vigorous efforts we can satisfy the demands that are being made upon us until contemplated expansions and improvements relieve the pressure under which we are working at the present time."

### E. ARMSTRONG NEW SALES MANAGER

CHICAGO, ILL., August 7.—Elmon Armstrong, who is known to the wholesale music interests in the Middle West, and very thoroughly and generally known in the musical industry from coast to coast, has been appointed Western sales manager for the Compton-Price Co., Coshocton, O., manufacturers of the Stradivara phonograph, with headquarters in Chicago.

### KIMBALL CO. TO HANDLE PATHE LINE

Prominent Chicago Piano Manufacturers Close Important Deal with Pathé Co.

CHICAGO, ILL., August 9.—An announcement based on authentic information was made here to-day to the effect that the W. W. Kimball Co. has closed a deal whereby it will handle the Pathé Frères line of machines and records not only in its retail department, but also in a wholesale way, distributing the goods to retail dealers throughout the country. This is the second large piano manufacturing corporation to tie up with the Pathé line lately, as the Hallet & Davis Piano Co. made distributing arrangements on the Pathé line only last week.

It is pointed out that the Kimball Co., incidentally placed itself in a more favorable position in respect to its own machine, which is to be known as the Kimball phonograph, and which is believed will be in readiness for the market very soon. The advantage of having a library of records such as the Pathé library is cannot be overestimated in conjunction with the launching of a new machine.

### SUCCESSFUL VICTOR RECITAL

Rhodes Bros. Entertain Large Audience at Recent Affair Given in Their Roof Garden

TACOMA, WASH., August 5.—Rhodes Bros., Victor dealers, recently held a Victrola recital in their building which attracted an audience of several hundred women and which was a success both from an artistic and a commercial standpoint.

The excellent attendance at this recital was made possible through the use of large newspaper space and the fact that the Rhodes Bros. building has a roof garden and tea room in which the recital was held.

In addition to the Victrola the services of two well-known local musicians were secured, and the program was made as varied as possible so as to interest every one.

The impression created by this recital has been reflected in the splendid business closed by Rhodes Bros., and it is quite likely that similar recitals will be held in the near future.

B. L. Malone & Co., of Grady, Tex., have added the Edison Diamond Disc line of phonographs and records to their business.

## Satisfy and Please Your Trade



Shrewd, progressive dealers do so by supplying them with the

## VICSONIA

knowing it is the *only* sound box that will reproduce Edison Disc

Records on other machines perfectly and with true fidelity to the original rendering.

Instantly adapted, no alterations necessary, to Victrola, Grafonola, Crescent, Sonora, Pathé; special type for Aeolian Vocalion. Two independent machines from one. Gold or Nickel Plated, permanent Sapphire or Gem Diamond points.

One Vicsonia, nickel plated, sapphire point sent any dealer in United States or Canada on receipt of \$4.

Prepare for Fall Trade; Order NOW

## Vicsonia Mfg. Company

313 East 134th Street

New York City

## VEECO

The Electric Drive of Supremacy  
for Talking Machines

Manufacturers and Dealers write to

### VICTOR Electrical Equipment Company

248 Boylston St. Boston, Mass.

One of the  
Domestic  
Line

The Wonderful  
Domestic  
Sound Box



## The Dominance of the Domestic

DOMESTIC Talking Machines comprise the logical moderate price line to handle. And here's why:

They have been designed and are being manufactured and sold by men who are recognized experts in this field.

They are being manufactured complete, with the exception of the wood work, under one roof.

The manufacturers concentrate in one field, devoting their entire attention to doing one thing economically and well.

The organization surrounding the Domestic line is of as high standing and broad knowledge as the largest manufacturers in the industry.

The Domestic line caters to the masses where values must be and are prominent factors to insure success.

All Domestic machines are full guaranteed, and the Domestic organization stands squarely back of them.

As a dealer you do business direct with the Manufacturer when you handle the Domestic line. You have something of value, something that is distinctive and different from others.

We are prepared to make prompt shipments, have materials on hand for a large output and expect to take good care of all our dealers by giving them a superior product along with efficient service.

The great value to the consumer, liberal discounts to the dealer and a broad sales policy insure each dealer reaping the benefit of his efforts.

We are closing dealers' contracts daily and hourly; our output is increasing by leaps and bounds.

If you have not as yet applied for the agency, do so now before your neighbor secures it. One thing is certain: someone in your locality is going to handle the Domestic line.

Can you afford to lose the opportunity?

### Domestic Talking Machine Corp.

HORACE SHEBLE, President

33d and Arch Streets, Philadelphia

GEO. W. LYLE

New York and New England Sales Agent  
815 Trinity Building, New York

WALTER S. GRAY

Pacific Coast Sales Agent  
422 Chronicle Building, San Francisco, Cal.

**Domestic**  
TALKING MACHINE

## MUSIC TRADE MEN AT PLATTSBURG

Trade Showing Not So Large as Might Be—Chicago Talking Machine Co. Well Represented—Life of the "Rookie" Not a Rosy One, But Does Much Good Declares Keith

PLATTSBURG, N. Y., August 7.—The third camp of the season of 1916 of the Military Training Camps has finished its last week of work in a "long hike," and is breaking camp in preparation to return to business and home.

The men have had a month's intensive military training and "intensive" means that the "Rookies" have had drilled into them in that time what the recruits joining the regular army would get in three or four months. For the



Left to Right—W. C. Griffith, Corp. R. J. Keith, Arnold Lockridge

army officers who acted as instructors at the camps were expected to impart to the business men in training as much as possible of the ground-work of a military education with the idea that ultimately these "Rookies" can serve in the event of war as a nucleus around which to build a force of officers for the armies that would have to be raised.

Members of the music trade were not in attendance at the camp to any great extent—for the music trade evidently does not believe in preparedness, at least, as far as itself is concerned. There was one firm, however, that made an excellent showing, and that was the Chicago Talking Machine Co.

Sales Manager R. J. Keith was there and brought with him W. C. Griffith and Arnold Lockridge, both of the sales department. The men were assigned to the same regiment—the Seventh—but were placed in different companies, Keith being corporal of his squad.

It isn't the easiest work in the world, sometimes, to keep a lot of prosperous Victor dealers satisfied with deliveries—especially around holiday time—but it's easy compared with what the "Rookies" have to do. In the morning is "Reveille"—at 5.40 and part of the time at 4.30 a. m. Then after "setting-up" comes mess, and after that marching or drilling and sometimes sham battles in which the men carrying the full pack of forty pounds on their backs and rifle, bayonet and belt, march through the dust and heat, deploy and fight a desperate battle with another battalion of "Rookies," firing innumerable blank cartridges and ending the struggles of the losing side in a desperate bayonet charge.

Then comes the tiresome march back to camp, sousing with buckets of water and noon mess. Then in the afternoon drilling by platoon or rifle practice on the range. Then comes "Retreat" with its ceremonies, "Inspection arms" and "Dismissed" followed immediately by the supper call. After the scramble for the "slumgullion" there is a conference in which the men are given a talk on "The Use and Care of the Rifle" or "Strategy at the Dardanelles," etc. After that an hour for yourself and then "Taps" with nothing to do 'till to-morrow. On the "hike" there is, in addition, making and breaking camp and attending to one's own meals.

"Oh! they worked us, all right," said Keith, "but it has done all of us a lot of good, and we have learned the lesson that army officers have tried to teach the public for the past two years. We know that even should 'vast citizen armies spring to arms' were war to develop, they wouldn't be worth a rap for six months. We have worked for a month, and the principal thing we learned was that we were mighty poor excuses for soldiers in spite of all our sweating and drilling."

## NEW COLUMBIA DEALER

Ellis Bros. & Joseph, Binghamton, N. Y., to Handle Line—Grafonolas in Burl Walnut—New Advertising Service

Among the recent new accounts opened by the Columbia Graphophone Co., New York, in near-by territory, was that of Ellis Bros. & Joseph, Binghamton, N. Y., who will handle the complete Columbia line and concentrate a considerable portion of its activities on the development of foreign record business. This concern caters to a large clientele in its territory, and the comprehensive scope of the Columbia Co.'s foreign record library will enable it to offer its customers an unlimited repertoire of foreign selections.

The Columbia Co. has advised its dealers that it is prepared to furnish burl walnut Grafonolas at a very moderate increase over the price of regular mahogany and oak finishes. The extreme scarcity of burl walnut has been the subject of considerable discussion among the dealers, as the wonderful figuring of the burl grain and its dark, rich coloring has made this finish quite popular throughout the country. According to the scale of prices announced by the Columbia Co., burl walnut Grafonolas may be obtained at the following prices, as compared with the regular finishes: Grafonola 85, burl walnut,

\$95; No. 100, at \$115; No. 110, at \$125; No. 150, at \$175; No. 200, at \$225. The prices quoted are the retail list prices for the various Grafonolas.

A new advertising service has just been offered to Columbia dealers whereby the dealer may tie up his name with the Columbia product in a distinctive, individual manner. Columbia distributors have been instructed to prepare a special hand-drawn design for each dealer requesting one, featuring his name with the popular "Note the notes" trade-mark. Electros can then be made in various sizes for single, double or triple newspaper column advertisements, for letterheads, billheads, envelopes or advertising circulars. This service is offered free of charge to all Columbia representatives.

## PAULIN USES THEATRE PROGRAMS

Local Victor Dealer Advertises by Means of Four-Page Colored Inserts

SANTA BARBARA, CAL., August 4.—Ralph H. Paulin, Victor dealer of this city, is using a series of theatre program advertisements which embody many unusual features, and are attracting more than passing attention from theatre-goers. He has had printed special four-page colored inserts advertising the Victor line, and these are placed in the programs of the local theatre and other places of amusements. These inserts cost very little more than a regular advertisement, and serve to produce far better results from every standpoint.

The Adolph Furniture Store, of Wheeling, W. Va., has opened a Columbia Grafonola department.

The Harmonola Co., Inc., has leased the first floor and basement of 1611 Chestnut street, Philadelphia, Pa., as general offices.

## We Carry Everything for the Victor Dealer

One of the largest and most complete Record Stocks in the East.

A full line of cabinets for all type Victrolas.

Record Delivery Bags, Supplement Envelopes. Supplies of all kinds.

A full stock of Victor repair parts.

Everything and anything you may need forwarded promptly and accurately.

When your Distributor fails you, try us.

**Blackman Service is REAL Service**



**Blackman**  
TALKING MACHINE CO.  
97 CHAMBERS ST. NEAR CHURCH ST. NEW YORK



Victor Distributors

## LARGER STOCKS BEING CARRIED BY DETROIT DEALERS

Faith in the Future Shown by the Manner in Which Trade Is Prepared for Demands—A Little Hint on Record Salesmanship—Pathephone Dealers to Hold Convention—Talking Machine Association to Meet and Discuss Interest and Approval Questions

DETROIT, MICH., August 7.—For months and months we have been announcing in the Detroit letter of The World that business locally was showing tremendous increases as compared with previous years, so that to mention it again would be repeating "an old chestnut." But we do want to say that the number of talking machine dealers in Detroit and throughout the State is increasing very rapidly from the statements made by Michigan Victor, Columbia, Edison and Pathé jobbers. We have stated before that the city of Detroit is showing marked development in its population and its territory and wherever the new districts are developing, both for residences and business, there is a field for one of the talking machine lines. Probably the greatest development is taking place through the State; every town with a population of 2,500 people and up offers a lucrative field to someone for talking machines. In making the rounds of dealers, both in Detroit and suburbs, as well as through the State, The World representative finds large stocks are being carried—much larger than a year ago—which means that dealers are optimistic.

That the talking machine is a great educator for higher-class music is the statement made by Wallace Brown, operating the Wallace Brown Edison Store at 31-33 East Grand River avenue. "Many of our customers when they first buy their machine ask for a lot of popular records, band music, etc.," he said. "But we notice that invariably about two or three months later they buy better music—operatic selections—music that is real music."

A mistake made by many machine and record salesmen is to put on the record and then walk away until about the time the record is completed, says one Detroit dealer, who contends that this is a serious mistake in salesmanship as applied to the talking machine industry. "No matter how many times the salesman hears the record, he should sit down with the customer and listen to it again just as if he had never heard it before and was enjoying every bit of it. I never could see that method of playing records with only the machine and the customer in the room—it looks too mechanical. If we are to have salesmanship in the talking machine business, then we must see that customers get individual attention. Selling records is different than selling groceries, cigars, or other commodities."

It is expected that September will surely see a renewal of the business meetings of the Detroit Talking Machine Association, by which time most of the dealers will have returned from their vacations—the weather will be cool—and everybody will be actively interested in business problems. There is sure to be an agitation against the approval system and an attempt made to get every dealer in Detroit to charge 6 per cent. interest. If some dealers persist in not charging interest, there is very apt to be some real fighting on the proposition by other dealers, now charging interest, who say "let's all do one thing or the other."

J. R. Peckham, general manager of the Pathephone Co. of Detroit, is anxiously looking forward to the first convention in Michigan of the Pathé dealers which is scheduled for some time in September. Mr. Peckham has sent out letters to dealers and the answers indicate that Pathé dealers favor such a get-together.

It isn't often that George Smith, of the Detroit Music (Columbia dealer) Co., 288 Woodward avenue, takes a vacation, but this year he cast business aside and toured to Niagara Falls, going by way of Canadian territory.

The "Carola" phonograph now has Michigan representation—the State agency having been placed with the Michigan Carola Co., with offices in the Equity building, Detroit. The "Carola" is made in Cleveland.

The Edison phonograph is being vigorously pushed on the east side by the East Side Diamond Disc Shop, at the corner of Gratiot and Townsend avenues. The shape of the store is triangular and is very conspicuous in that section. The store is under the management of William Cummings, who has done very effective work in Detroit as an Edison demonstrator. The owner of the enterprise is a well-known East Side druggist.

Great preparations are being made at The Edison Store, Woodward avenue, Detroit, for a whopper fall trade. On every floor improvements are being made that call for greater efficiency. The Phonograph Co. of Detroit, occupying part of the same building, is also making changes to get prepared for the prompt rendering of service to its retail customers.

At Grinnell Bros., C. H. Grinnell, manager of the jobbing (Victor) department, and Harry Rupp, manager of the retail store, report good business for the first six months of 1916—better than previous years—with the outlook very bright for the balance of the year.

Max Strasburg, of Detroit, spent ten days of August at the summer home of his brother at Point Aux Barques, Mich. Mr. Strasburg told The World that he never carried as large a stock of talking machines and Grafonolas as at the present time. He felt sure that the coming fall would be a most successful one.

"The Melodophone" is the trade name of the talking machine which the Clough & Warren Piano Co., of Adrian, Mich., is just bringing out. They will be sold at all of the company's retail stores. The Detroit store is in the University Building and managed by R. L. Dupraw.

Edward Lyons, representing the Eclipse Musical Co., of Cleveland (Victor jobbers), was a recent Detroit visitor.

S. H. Nichols, district manager of the Columbia Graphophone Co., with headquarters at Pittsburgh, was also a recent Detroit visitor.



## How Big Should a Record Be?

Lincoln's much quoted opinion concerning the length of a man's legs serves as an apt guide to the solution of this problem. A record should be big enough to contain the music of a complete selection. Whether the record is seven inches in diameter, or 22, as some European records are, all we can require is that it play a complete selection.

DOMINO DOUBLE DISC RECORDS, though only seven inches in diameter, play for about three minutes, long enough for the average selection, and as long as the ordinary ten-inch record now on the market. This is possible because of the DOMINO method of recording, which allows 150 grooves to the inch as against 90 on most ten-inch records. This style of recording is direct and complete, marking a new era in record convenience.

DOMINO RECORDS play on all phonographs made to play vertical cut records and on all phonographs with a universal tone arm. When used on machines made to play only lateral cut records a small inexpensive and easily adjusted attachment is necessary.

## Dealers

DOMINO RECORDS offer you the opportunity we believe you have been seeking. Their popular price—Three for One Dollar—will increase your customers' interest in the enlargement of their record libraries. This means for you many more sales and continuous profits.

Arrangements should be made now to insure prompt shipments of new Fall recordings.

## INTRODUCTORY OFFER

The widespread response made to our Introductory Sample Offer made last month has induced us to repeat it. Twelve selected double disc records (selling price, 35c or 3 for \$1.00) illustrating the Domino standard, popular, comic, vocal and instrumental selections, will be sent postpaid to any dealer for \$2.50. Or a double sample order of 24 records for \$5.00. Catalogues mailed on request.

Factory Distributors

THE W. R. ANDERSON COMPANY  
220 FIFTH AVENUE  
NEW YORK

Are You Satisfied That the SOUND BOX on Your Machine Has a SATISFACTORY DIAPHRAGM?

## "CRYSTAL EDGE"

(The Edge is Clear as Crystal)

### MICA DIAPHRAGMS

Will Meet the Most Exacting Requirements

Can be furnished in any quantities  
Prompt deliveries assured

Only highest grade MICA used  
Write for samples and prices

**JAMES FRAZEE, 30 CHURCH STREET, NEW YORK**

### AN ENTHUSIASTIC BASEBALL TEAM

Organized and Equipped by the Employes of the American Talking Machine Co., Brooklyn

Through circumstances over which they have had no control, such as unexpected vacations, etc., the members of the baseball team of the American Talking Machine Co., Victor distributors of Brooklyn, N. Y., are to be commended for their willingness rather than their accomplishments. The team has, however, crossed



American Talking Machine Co.'s Baseball Team  
Standing, Left to Right: Herman Rushin, George Henkel, Albert Fountaine, James Williams, John Pittari, Gustaf Nelson. Sitting: Henry Dillon, Robert Bigelow, Albert Thraves, Max Gottlieb.

bats twice with the team representing the G. T. Williams Co., of Brooklyn, and divided the wins. There have also been a number of scrub games of unofficial character indulged in for practice purposes. The team is uniformed and enthusiastic. It is probable that it will play some other team in the trade at the outing of The Talking Machine Men, Inc., at Rye Beach, in September, although the matter has not been settled definitely.

David Bacon Richardson is the new member of the Richardson Illustrating Co., New York, the proud father being P. Bacon Richardson, head of the concern. Young Master Richardson, while only a few days old, is already giving vocal indications in fortissimo effects that he is a live issue.

### VALUE OF ADVERTISING SERVICE

Offered by by Lyon & Healy to Victor Dealers  
Wins Commendation of Arthur D. Geissler

In a recent chat with The World, Arthur D. Geissler, vice-president of the New York Talking Machine Co. and the Chicago Talking Machine Co., Victor distributors, stated that the Victrola advertising service being offered to Victor dealers by Lyon & Healy, Chicago, is one of the best things yet put out as an aid to the dealer.

He stated that any dealer who can afford to use in his local papers the amount of space required for good, efficient advertising certainly cannot afford to overlook the opportunity offered them by Lyon & Healy to get cuts in which are incorporated high class drawings by excellent artists, together with suggestions of live up-to-date text matter which can be altered to fit his local conditions.

Only the fact of Lyon & Healy's enormous retail business and their opportunity to get up these drawings and advertising for themselves could have made this advertising service possible at the very reasonable charge asked.

Mr. Geissler states that he certainly shall recommend that the live dealers of the New York Talking Machine Co. and the Chicago Talking Machine Co. take advantage of this offer.

### "BUSINESS TRULY REMARKABLE"

Says E. A. Widmann, President of the Pathé Frères Phonograph Co., In Discussing Conditions—Receiving Some Large Orders

"Business conditions at the present time are truly remarkable," said E. A. Widmann, president of the Pathé Frères Phonograph Co., New York, in a chat with The World. "We have received some unusually large orders from our distributors, and judging from indications at the present time, this fall will be a record-breaking season for all factors of the talking machine industry, and I am glad to say that Pathé dealers will evidently share in this prosperity.

"We are making every effort to increase our factory facilities all along the line, and I think that we can safely assure our distributors and dealers maximum efficiency and co-operation in their shipments this coming fall."

### SHEBLE TALKS OF "DOMESTIC" AGE

Head of Domestic Corporation Says This Is the Age of Specialists in the Trade and Talks of Various Phases of the Business

While this may be the age of specialists and the era of the man who does some one thing best, in the talking machine business it is the age of the man who has grown up with the invention from the beginning, through every phase of its development."

So says Horace Sheble, president of the Domestic Talking Machine Corporation and creator of the Domestic talking machine, which in a short time has won much success. Mr. Sheble then proceeded to divide the ages of the talking machine business as historians divide the ages of life, beginning first with the experimental stage and leading up finally to present day system of greater output, reduced cost, and catering to the masses in the sale of a machine. Mr. Sheble was asked why he called his new machine the Domestic when the "olas" were so popular with so many other makers. "Well," he said, "the Domestic isn't an imitation of any other machine, and I see no reason to suggest that it is even by name. Then, again, the Domestic is just what its name implies—a machine for home lovers for those who take pride in their home and enjoy all the comforts of life without false extravagance. No income tax list is necessary to prove that there are at least fifty million of these people whom the Domestic can help domesticate their homes."

### OPERATING ENTIRE PLANT

Schloss Bros., Now Completely Recovered from Effects of Recent Fire—Buy New Auto for Local Transportation Purposes

Schloss Bros., manufacturers of talking machine cabinets at 637-645 West Fifty-fifth street, N. Y., are now operating the top floor section of their factory at full blast just as before the upper floor of the plant was wrecked by lightning some two months ago. The demand for cabinets for early delivery make the recovery of this space particularly welcome. After the fire Schloss Bros., put extra pressure on the undamaged section of their plant with the result that there was little, if any, delay in deliveries. In order to facilitate his work among the local dealers Edwin G. Schloss, general manager of the company, has purchased a new Maxwell car to solve the transportation problem.

### RECENTLY INCORPORATED

The Meir Specialties Corp., of Wilmington, Del., was recently incorporated for the purpose of manufacturing and selling talking machine needles of steel, wood and bone. The capitalization is \$100,000, the incorporators being C. L. Rimlinger, Norman P. Coffin and Clement M. Enger.

## "The Best I Have Seen." "Rush My Order."

When leading phonograph manufacturers say openly that our line has "hit the spot" and then back up these nice words with orders for five and ten thousands of our

### New Universal Tone Arms and Sound Boxes

we feel that you ought to know it. Manufacturing skill shows at its best in our new line of Universal Tone Arms and Sound Boxes, which produce a volume, sweet and mellow, that will please the most exacting of your customers.

There is one rule, which if followed, profits anyone, "Buy the Best," whether in tone arms or door knobs.

If you want to use an exclusive type of tone arm or sound box, send us rough sketch and we will submit our quotations, which will be unusually low—consistent with high quality.

You can share in the enormous profits now being made in the

phonograph trade by "Buying the Best"—THE CONSOLIDATED LINE OF UNIVERSAL TONE ARMS AND SOUND BOXES.

All parts finished in nickel, gold, silver or oxidized plating.

Write us before you place your orders for the season's requirements. Write today.



**CONSOLIDATED PHONO PARTS CORP.**

142-146 West 14th Street.

Telephone 989 Chelsea

New York City

OUR BEST ADVERTISEMENT—SATISFIED CUSTOMERS

TELEPHONE WORTH 1480  
1481

CABLE ADDRESS: CRESCALCO NEW-YORK  
LIEBER & COOP



**CRESCENT TALKING MACHINE CO., INC.**

89 CHAMBERS STREET

NEW YORK, May 2, 1916.

Doehler Die Casting Co.,  
Court & 9th Ste.,  
Brooklyn, N. Y.

Gentlemen:

Upon moving into our new offices, we wish to take the opportunity to express our appreciation not only of the quality of the merchandise, which you have delivered to us during the years we have done business with you, but also the excellent service and untiring efforts, which all the members of your company, who have anything to do with our parts, have given us during this time.

Our greatest desire is to build a phonograph which at all times stands for quality, and excellent workmanship, and we count upon your co-operation in the future as we know that, in your line that your product is unexcelled, and also to let you know that we appreciate your prompt deliveries, and unvarying quality during a period when other manufacturers are taking advantage of the difficulties due to the unsettled market conditions.

With very best regards, we remain,

Very truly yours,

CRESCENT TALKING MACHINE CO., Inc.,

*W. H. H. H. H.*  
PRES.

WEH+LL



**DOEHLER DIE-CASTING CO.**

**BROOKLYN, N. Y.**

**NEWARK, N. J.**

**TOLEDO, OHIO.**

## INTERESTING AEOLIAN-VOCALION WINDOW DISPLAY

St. Louis, Mo., August 5.—A show window display at Aeolian Hall last week showing an Aeolian-Vocalion in the midst of a vacation scene attracted much attention. The summer house was in the distance, everything being worked out nicely as to grading, foliage, lawn, lake, etc. The figures were dolls and they were having a gay time while a Model D machine supplied the music. Manager R. E. Ching originated the idea.

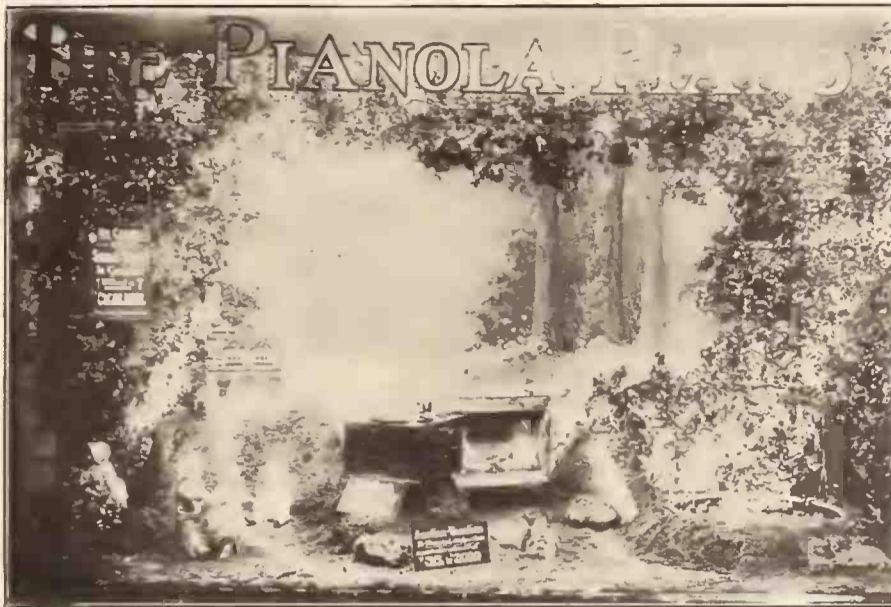

## HOT WEATHER HELPS RECORD SALES

At Least This Is the Claim of Some Twin City Dealers—Talker Proves a Solace—Columbia Manager Preparing for Fall—Sales Staffs Being Increased—News of the Travelers

MINNEAPOLIS and ST. PAUL, MINN., August 7.—Hot weather does not stimulate the sale of talking machines, but it does boom the record business in a pleasing manner, the Twin City dealers have discovered since the superheated period began. When it is too warm to dance, too warm even for motoring, and the majority haven't even the energy to make their way to the bathing beaches the talking machine is a solace and a comfort, provided it is fed with new records. Hence the stimulus to the record sale.

The summer trade in Minneapolis and St. Paul alike has been far ahead of that of 1916. This is the announcement alike of the Beckwith-O'Neill Co., jobbers, of the Victor lines, Laurence H. Lucker, jobber of the Edison goods, and Robert Souders, Northwestern representative of the Columbia Graphophone Co.

The Victrola license in St. Paul held by Raudenbush & Sons, has been transferred by the Beckwith-O'Neill Co. to the Golden Rule department store, in St. Paul, which is to greatly enlarge and organize its talking machine department. The Gustafson-Taylor Piano Co., Minneapolis, has opened a talking machine department and is handling the Columbia line.

Robert Souders, of the Columbia Co., learned a lesson in preparedness last December when he was caught by an unexpected rush of orders and was unable to fill them. This will not happen in 1916. He has leased the entire fourth floor of the Childs' building, on Nicollet avenue, and has filled it with machines and supplies. This is the reserve stock and current orders are being filled from the old quarters on the third floor.

Laurence H. Lucker, president of the Minnesota Phonograph Co., Edison representatives in this district, reports that the July trade for his house was about four times as large in volume as for July, 1915. The outlook for a bulky fall trade is most encouraging as all the rural dealers are banking on doing better than ever.

Mr. Lucker recently has added two high class men to his staff. C. A. Briggs, formerly with the Edison Co. in New York, and J. R. DeSaxe, formerly with the Phonograph Corporation of New York. Mr. Briggs will tour the Northwest and Mr. DeSaxe will have charge of the advertising.

The Beckwith-O'Neill Co. has been minus the services of Eugene F. O'Neill for more than a month. He has not returned from the convention yet, but is due soon. After the big meet he visited the Victor factories and headquarters, and then went to Boston to look up friends and relatives. The company has been somewhat handicapped by its inability to obtain machines to keep pace with the demand.

Archie Matheis, of the Talking Machine Co., this city, and his wife have just returned from an interesting trip to Yellowstone Park, which they enjoyed in their motor car. The trip out took a week over long stretches of roads and trails difficult to circumnavigate, and through eighty-five miles of scenery which is so beautiful as to defy description in cold type. They had some rain and storms—enough to make it a hard trip, but difficulties of this kind are to be looked for, and they enable a man to cope with the most difficult problems in the talking machine field. Mr. Matheis, by the way, was one of the first to send a Victrola to the boys of the First Minnesota, who are down in Mexico.

The Tonola Phonograph Co. has started to manufacture phonographs at 711 Fifteenth avenue, N. E. L. A. Priess, well-known in the local piano trade, is the head of this concern.

## COMPANY REORGANIZED

The Majestic Talking Machine Co. Elect New Officers and Will Have Capital Stock of \$500,000—Occupy Six-Story Factory

CHICAGO, ILL., August 7.—Arrangements have just been completed whereby the Majestic Talking Machine Co. is to be re-organized and backed by sufficient capital to insure its being, within the coming year, one of the big factors of local talking machine manufacture. Formalities of increased stock have been complied with and the reorganized concern will have the backing of capital stock amounting to \$500,000. In the past the company's activities have been hampered by a lack of capital sufficient to handle the company and its product properly.

C. A. Hartman, president of the American Bankers' Service Co., is the leader of the new interests. He is a business man of long standing and will bring to the company, in addition to new financial backing, much valuable experience in commercial affairs. Although Mr. Hartman will become treasurer of the new company, he will continue to make his offices at room 1614 Republic Building.

The six-story plant formerly used by the Gulbransen-Dickinson Co., manufacturers of pianos, player actions, etc., which is located at 312-314-316 Union Park Court, has been taken over and the first lot of 500 Majestic machines to come out of the new factory is now in the course of completion. A similar number of machines will be turned out every fifteen days until new equipment will make it possible to radically increase this number.

"We feel that we have, in the Majestic, a commercial proposition of the highest character," said Mr. Hartman, "and we also think that in the acquisition of the patents of our president, Mr. Blood, we have further cause for optimism. We will be able to handle, because of our immediate banking connections, paper of both the dealer and the consumer and we will take it in any amounts."

Mr. Blood will continue as president, Mr. Hartman will be treasurer and O. J. Kloer as sales manager. Other officers have not yet been announced.

## REARRANGES BROOKLYN STORE

The Ranah Co., Victor dealers at 10 Fourth avenue, Brooklyn, N. Y., has recently rearranged its store, adding five new demonstration booths, besides enlarging their space devoted to records. The interior has been re-decorated and the exterior has also been improved by being repainted.

Joseph F. Collins, sales manager of the Pathé Frères Phonograph Co., New York, returned Monday from a two weeks' stay at Woodbourne, N. Y. He confirmed his reputation for conservatism by stating frankly that his entire catch of fish during that period consisted of one lone fluke.

# TOLEDO

and

First of all  
Reliability

# The

# Victor

HERE is the home of good automobiles and good Victor service. We use every motive power to give you a Service of Reliability—one that you can depend upon.

Record deliveries is our specialty. Send us ten or one hundred numbers and we'll actually deliver.

## THE WHITNEY & CURRIER CO.



VICTOR  
Distributors

TOLEDO, OHIO



A personally selected list of records which you should have in your home. Kindly mark any you would like to hear, and it will be a pleasure for us to play them for you.

13472   Some Things About the Gold From You and I with Tiny Tim Columbia	25	16552   Lullaby Baby Lullaby Baby and Baby's Day Columbia	25
17322   I'm Sorry I'm Not a Millionaire Columbia	25	16553   Uncle Sam in a Cowboy Suit Columbia	25
17353   The Modern Playhouse Columbia	25	16135   I'm Sorry I'm Not a Millionaire Columbia	25
17377   I'm Sorry I'm Not a Millionaire Columbia	25	16236   I'm Sorry I'm Not a Millionaire Columbia	25
17443   I'm Sorry I'm Not a Millionaire Columbia	25	16413   I'm Sorry I'm Not a Millionaire Columbia	25
17701   I'm Sorry I'm Not a Millionaire Columbia	25	16443   I'm Sorry I'm Not a Millionaire Columbia	25
17716   I'm Sorry I'm Not a Millionaire Columbia	25	16521   I'm Sorry I'm Not a Millionaire Columbia	25
52723   I'm Sorry I'm Not a Millionaire Columbia	25	16968   I'm Sorry I'm Not a Millionaire Columbia	25
50831   I'm Sorry I'm Not a Millionaire Columbia	25	16285   I'm Sorry I'm Not a Millionaire Columbia	25
62518   I'm Sorry I'm Not a Millionaire Columbia	25	17222   I'm Sorry I'm Not a Millionaire Columbia	25
64128   I'm Sorry I'm Not a Millionaire Columbia	25	17231   I'm Sorry I'm Not a Millionaire Columbia	25
64181   I'm Sorry I'm Not a Millionaire Columbia	25	17299   I'm Sorry I'm Not a Millionaire Columbia	25
64296   I'm Sorry I'm Not a Millionaire Columbia	25	17324   I'm Sorry I'm Not a Millionaire Columbia	25
65218   I'm Sorry I'm Not a Millionaire Columbia	25	17384   I'm Sorry I'm Not a Millionaire Columbia	25
87195   I'm Sorry I'm Not a Millionaire Columbia	25		

Conditions in the Paper Market are such that it will Pay to Order Record Envelopes for Holiday Trade NOW

SAMPLES AND PRICES ON APPLICATION

- Record Delivery Envelopes
- Record Stock Envelopes
- Catalog Supplement Envelopes

- Long Cabinets
- Bagshaw Needles
- Perfection Record Holders
- Peerless Locking Plates

CLEMENT BEECROFT, 309 W. Susquehanna Ave., PHILADELPHIA

**BANNER MONTH IN LOS ANGELES**

July Trade of Most Satisfactory Proportions—Andrews Talking Machine Co. in New Home—Window Display of Records of the World—So. California Music Co.'s Departments

LOS ANGELES, CAL., August 7.—July has proved to be a banner month for all of the talking machine dealers in Los Angeles. Usually a comparatively slow month of the season, this hot month has upset all predictions and has shown itself as a delightful surprise to the trade in general.

The Andrews Talking Machine Co. has moved its headquarters from 422 South Broadway to 350 South Broadway. The new shop is very tasteful in every detail and up to the minute in modern fixtures. There are seven record booths, each well lighted and ventilated. The first two booths are arranged so that it is possible to make one large room out of them, if necessary. The store is lighted throughout with clusters of small electric lamps attractively arranged. The Andrews Co. will, as formerly, handle the Edison disc, Victor and Columbia.

At the Wiley B. Allen store Manager Lindsey reports a very exceptional total of July sales. Many of the force at present are away enjoying vacations, and those remaining are kept busy during the absence of the others, by the unusual summer business.

**HALLET & DAVIS CO. OPEN TEN DISTRIBUTING OFFICES**

Piano Manufacturers Will Establish Branch Offices All Over the Country to Distribute the Pathé Frères Line of Talking Machines and Records—Business in Charge of Harry T. Leeming

CHICAGO, ILL., August 7.—Announcement is made here to-day that the Hallet & Davis Piano Co. will open here within a few days the first of ten distributing offices through which the company will distribute the Pathé Frères line of talking machines and disc records.

Harry T. Leeming, formerly with the Edison interests, will manage the new phonograph division of the Hallet & Davis Co.'s activities and will appoint in each of the ten cities to be selected a district manager who will have

The Geo. Birkel Co. reports the best July business in the history of the concern, and the best month of the year since the winter. The Birkel people handle the Victor exclusively.

Manager Boothe, of the talking machine department at Barker Bros., reports himself as being more than satisfied with his July sales, and is looking forward to an equally good August. This firm now handles the Edison cylinder line, in addition to the Edison disc, Victor and Columbia.

F. S. Allen, proprietor of the Musical Record Co., offers one of the most unique and interesting window displays seen in the city for a long time. It consists of records made in all parts of the world. Mr. Allen collected these

charge of that territory. Chicago has already been placed upon the list and the quarters of the Pathé Pathephone Co. of Illinois, located on the fifth floor of the Shops Building, at 17 North Wabash avenue, have been taken over and will be ready for business shortly. R. O. Ainslie will be office manager and Frank J. Bowers will act as special representative to be identified with the work of opening up the other distributing points for pushing this line of talking machines.

records while on his recent visit to New York City. In the collection may be found discs from London, Paris, Berlin, Prague, Petrograd, Peking, Smyrna, Jerusalem and many other far-away places. The Musical Record Co. carry the Edison disc and Victor lines.

E. W. Bornell, manager of the Pathé Shop of this city, tells of a fine business month and expects to have a splendid autumn, as the new model Pathé will be on the market at that time. Mr. Bornell is strongly in favor of organizing a retail talking machine dealers' association similar to that in San Francisco. Many of the local trade are similarly disposed and it is believed that efforts of organization in this direction will soon be inaugurated.

The Southern California Music Co. now has two separate phonograph departments. The Edison department, which includes all Edison Diamond Disc and Edison Amberola machines is under the direct supervision of Wm. H. Richardson. Mr. Richardson has been with the above firm ten years and heretofore has had charge of the entire talking machine department. The other department, known as the talking machine department and including all Victor and Columbia goods, is in charge of H. H. Fish.

Jesse Rosenstein, of the National Piano Co., Baltimore, Md., Pathé distributor, was a visitor this week at the executive offices at the Pathé Frères Phonograph Co., New York. He spoke encouragingly of trade conditions and placed a good-sized order for Pathephones and Pathé discs.

**CABINETS**



WE manufacture a complete line of disc record cabinets in all styles and finishes. These cabinets fit perfectly all types of machines and are guaranteed in every particular. Our prices are moderate, enabling you to make a good profit on every sale.

Place your orders now for your Fall requirements.

ESCO WAGON ILLUSTRATED  
44 inches high; 17 inches wide; 20 inches deep. Fits Victrola IX.

NANES ART FURNITURE CO.  
GRAND ST. and East River, NEW YORK

**ILSLEY'S Graphite Phono Spring Lubricant**

The Perfect Lubricant for Talking Machine Motors, Mainsprings, Gears, Etc.

Write for descriptive folder and prices

Manufactured by  
**ILSLEY - DOUBLEDAY & CO.**  
Established 1853  
229-231 Front Street New York, N. Y.



The Columbia selling policy is what the insurance people would call an *accumulative* policy, because its value has an annual increase.



(Write for "Music Money," a book "full of meat" for those dealers interested in quick and frequent turnover of capital.)

Columbia Graphophone Co.  
Woolworth Building, New York

**DISCUSSES EDUCATIONAL VALUE**

Of the Talking Machine—Interesting Views of H. A. Yerkes, Western District Manager of the Columbia Co., on Live Subject

In a recent interview in the Denver "Rocky Mountain News," H. A. Yerkes, Central Western district manager of the Columbia Graphophone Co., interestingly discussed the educational value of the talking machine, and its importance in promoting an appreciation of the better class of music.

Mr. Yerkes' talk was published in connection with the recent song contest held in Denver,



H. A. Yerkes

Col., which was described in detail in last month's World. The winners of this contest visited the Columbia Co.'s laboratories in this city and made a record which has been pronounced a signal success.

In one section of his interview, Mr. Yerkes said:

"Anything that stimulates an interest in community music should be encouraged. And certainly we cannot begin to estimate the value of a contest that brings to light talents that otherwise might have been lost to the world. Very often young singers are too timid to display their gifts. All they need is encouragement.

"The News-Times-Columbia contest was an educational thing and the Columbia Co. is always looking for educational ideas. Records are one of the greatest of all educational factors. They have brought good music to homes everywhere. In country districts, where good music was unknown you will hear the boys whistle 'Il Trovatore' and 'Faust,' for the talking machine has made the classics as familiar to them as 'Yankee Doodle' and 'Dixie.'

"Little tots learn to carry tunes from hearing the records. It teaches languages and special folklore. Its use in schools is increasing. Our company has specialists who do nothing else but seek for ways of making the talking machines of even more value to the educational world.

"All the time we are seeking to improve the Columbia Grafonola. We have four of the best inventors in the world working to make it better. We have the two best chemists in this country working for us and managers everywhere are seeking for new ideas.

"Our catalogs form a complete library of music. Each contains a treatise on the composition, the composer and the inspiration. The boy or girl in whose home there is a Grafonola learns from our catalogs the history of the piece played and the history of the composer. The catalogs give information that is educational even to the trained musician."

**PATHE DANCE RECORDS POPULAR**

Numbers Recorded by Rector's New York Dance Orchestra Finding a Ready Sale

The Pathé Frères Phonograph Co., New York, has just sent out a letter to its jobbers and dealers calling attention to the character of the Pathé dance records, recorded by Rector's New York Dance Orchestra. As indicative of the success of these dance records the company calls attention to the following letter recently received from the State Street Pathephone Co., of Chicago.

"The dance record, 'Honky Tonky' (No. 35038), played by Rector's New York Dance Orchestra, is a very good seller. It is played by the kind of an orchestra that the people like. It should be profitable for you to put out

a number of the up-to-date selections, played by just this sort of an orchestra, in your coming monthly supplement. We have a considerable demand for 'Walkin' the Dog,' and also 'Pretty Baby' records. The new Grace Hoffman record (No. 52001) is very fine and everyone seems to want it."

**NEW DISPLAY FIXTURE FOR DEALERS**

New Rack for Record Lists Opens Up in Flat Position and Is Easily Installed

The new swinging fixture for record lists just put out by the Universal Fixture Corp. of New York City, involves a new and practical advantage. The rack, instead of opening up in the usual V shape, swings back flat, no matter at what point the rack is opened up. This naturally has a decided display advantage in that it means the cards will be plainly legible clear across the room. The rack itself is surprisingly light, is finished in a handsome black and can be located anywhere with two screws.

That record lists appearing in swinging display fixtures are a great advantage in promoting sales for the lists of "timely" records is not a proposition requiring argument. The new company in the field, realizing this, are launching a campaign to cater directly to and for the dealer, whether that dealer handles Victor, Columbia, Pathé, Edison or other lines.

Order liberally now—Christmas is coming!

**BALANCE SOUND BOX**



Half Size No. 2

THE new No. 2M Balance Sound Box, with the improved Metalloy Diaphragm is a revelation for tonal reproduction. Several of the largest phonograph manufacturers have adopted it.

Strictly high class. Jobbers and manufacturers write for prices. We can make prompt delivery. No orders too large or too small.

**A. F. Meisselbach & Bro.**

Factories: Prospect Street and Congress Street  
Office: 29 Congress Street

Newark

New Jersey

We also manufacture  
**SAPPHIRE NEEDLES**

**TONE ARMS**  
Made from brass tubing, light and highly finished

**MOTORS**  
Only of the highest quality



*Hotel Brevoort*  
ANNEXEMENT BREVOORT HOUSE

Coin de la 5me Avenue et de la 8me Rue  
CABLE ADDRESS LAFBREVORT

New York, Aug. 5<sup>th</sup> 16  
My Dear Mr Manoil  
I am delighted with  
my manophone and amazed  
at the perfection with which  
it reproduces all types of music,  
both vocal and instrumental.  
The graceful design  
and finish of the cabinet  
is as great a delight to  
the eye as its musical  
quality to the ear -  
Sincerely Yours  
Lucille Lawrence

Read what this noted artist has to say about the *Manophone*.

It is a true artist's expression of approval, the greatest recommendation possible for a musical instrument.

## Lucille Lawrence

Prima Donna Soprano

The brilliant American soprano whose phonographic records are among the most sought after in Italy to-day.

Miss Lawrence is a finished artist—her knowledge of music is exceptional. Read what she has to say about the *Manophone*. An unsolicited expression from one who knows should convince you far more than anything we could say about this new and wonderful machine.

# JAMES MANOIL CO

Executive Offices 60 Broadway New York

# Opinion Of One Who Knows

## *The Manophone*

has already won the admiration and approval of those whose knowledge of music makes them competent judges of musical quality.

The Manophone leaves nothing to be desired, be it richness of tone, volume of sound, or the true reproduction of the most delicate musical instrument—all these and more are its attainments.

The beauty of the cabinet work of the Manophone is worthy of its musical quality and mechanical refinements.

The Manophone owing to its exclusively constructed tone-arm, plays all makes of records perfectly. It is one of the few machines on the market which represents how well a phonograph can be made and not how cheap.

The complete Manophone line is now ready. Its range includes models at \$15, \$30, \$50, \$75, and \$100.

Every instrument is a remarkable value at the price and allows you a most liberal profit.

Our advertising will be extensive and complete. It will be of a distinctive and unusual nature. It will bring interested buyers to the stores of Manophone dealers.

Get in touch with us now and get the details of this new and wonderful talking machine.

**Exclusive territory still open. An unusually liberal proposition for those who write first. Send for catalog.**

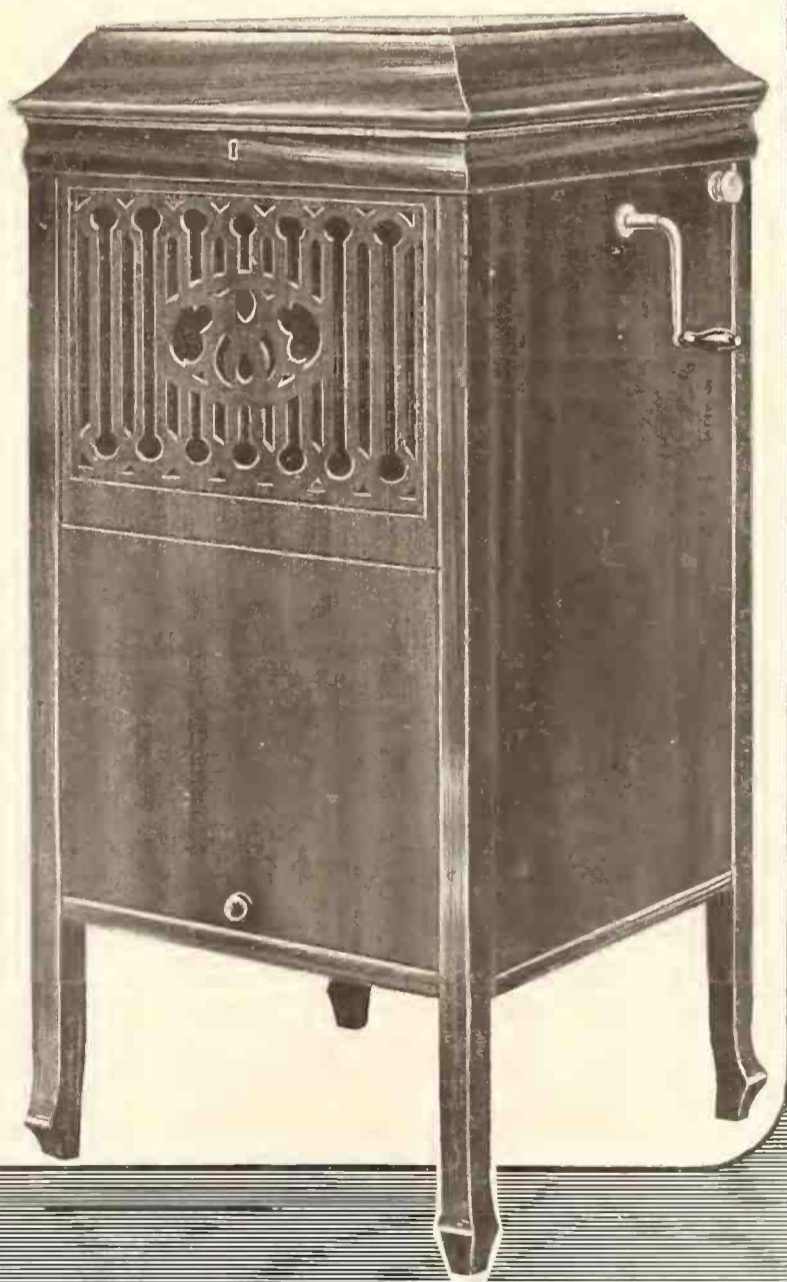

# PANY Inc.

Factory Newburgh N.Y.

AN EFFECTIVE LETTER FOR THE USE OF DEALERS

CHICAGO, ILL., August 8.—One of the most popular things the Chicago Talking Machine Co. has ever done for their dealers is supplying them with expertly constructed letters, neatly printed in imitation typewriting on attractive letter heads. The cut which extends across the top of the letter shows a large group of Red Seal artists clustered around a mahogany Victrola. The letter, which is designed to accompany the monthly Victor bulletin, tells about the principal numbers in a snappy, convincing manner, and is furnished the dealer with his "signature" all ready for mailing. The company also furnishes the dealer with mailing envelopes bearing his reprint and advertisement of one or two of the feature records. With the equipment goes the requisite number of bulletins also with the dealer's reprint. All he has to do is to fold letters, insert them, with the bulletin, and stamp and



TO OUR CUSTOMERS:—

July the twenty-seventh  
1916

It isn't often that a popular song makes such a big hit that the Victor Company have to put it out again.

But that's just what has happened with "MY MOTHER'S ROSARY" and "YAKA HULA HICKEY DULA". This time the selections are made by the Avon Comedy Four - new artists for the Victor - but very favorably known by vaudeville goers. They give a new version of these justly popular numbers.

Another number you'll surely like is "WHEN THE SUN GOES DOWN IN ROMANY" from "STEP THIS WAY" by the Sterling Trio - It's chuck full of melody.

For those who like sentiment in their music - and we all do more or less, don't we? - there's "LOVE ME AT TWILIGHT" a pretty little ballad that is very pleasingly interpreted by Herbert Stuart.

After all though, it's hard to beat the old songs for simple, sweet melody. That's why everybody will enjoy "IN THE GLOAMING" by the McKee Trio. It's doubled with a delightful new number "SUPPLICATION" played by the same talented trio.

Then there's another new artist who has joined the long list of Victor Headliners - Miss Mabel Garrison - a wonderful coloratura soprano of the Metropolitan Grand Opera. Her singing of the "LULLABY FROM ERMINIE" is exquisitely done - You'll be glad to have a record of this gifted soprano in your collection.

To balance up this unusually attractive list for August is the "STAR SPANGLED BANNER" by Geraldine Farrar - certainly a most timely offering and sung in a most inspiring way by this patriotic, truly American woman.

There are loads of other good numbers - let us play them for you. Don't forget that July 28th is Opening Day for these new August records.

Very truly yours,

HARRIS DRUG CO.

Towner, N. Dakota.



Reproduction of Letter Prepared by Chicago Talking Machine Co.

address the envelope. This service is given to the dealer practically at cost to the Talking Ma-

chine Co., and they get quantity rates which are only a fraction of what the dealer would have to pay otherwise, and which would prove prohibitive. One of these letters is here reproduced.

DEATH OF CLYDE H. SLEASE

Clyde H. Slease, treasurer of the Lynn Phonograph Co., New York, was killed last week in an automobile accident near Goshen, N. Y. Mr. Slease who was prominent in the business world, was thirty-five years old. He is survived by a widow and three children.

LIST OF FOREIGN RECORDS

The Victor Talking Machine Co. sent out to its dealers recently a group of foreign and domestic supplements of new records which are worthy of more than passing attention, considering the season of the year. The foreign record supplements included new Bohemian, German, Greek, Hebrew, Hungarian, Italian, Polish, Roumanian, Russian, Ruthenian, Spanish and Swedish Victor records.

A VISITOR FROM TEXAS

E. B. Shiddell, manager of the Columbia Graphophone Co.'s wholesale headquarters at Dallas, Tex., was a visitor to New York last week, with optimistic reports of conditions in the "Lone Star" State. In common with other Columbia distributors, Mr. Shiddell has been inconvenienced to some extent by the shortage of Columbia product, but he was delighted to find that the Columbia factories were increasing their output day by day.

The Motion Picture Welfare League, Inc., New York, has been incorporated with a capital stock of \$5,000 to manufacture and deal in phonographs, supplies, motion pictures, etc. The incorporators are M. Perlman, G. Littman and J. H. Maynard.

We Are the Originators of

The Famous

Our three most popular styles



Wagon Cabinets

Your stock not complete without them



700—Mahogany, Golden, Fumed or Weathered Oak for Victrola IX. No. 601 for Old Victrola IX. 603 for Columbia Favorite. 604 for Edison A-80.



602—Golden Oak or Mahogany for Victrola VI. No. 706 for Columbia Eclipse. 707 for Columbia Jewel. 708 for Victrola VIII.

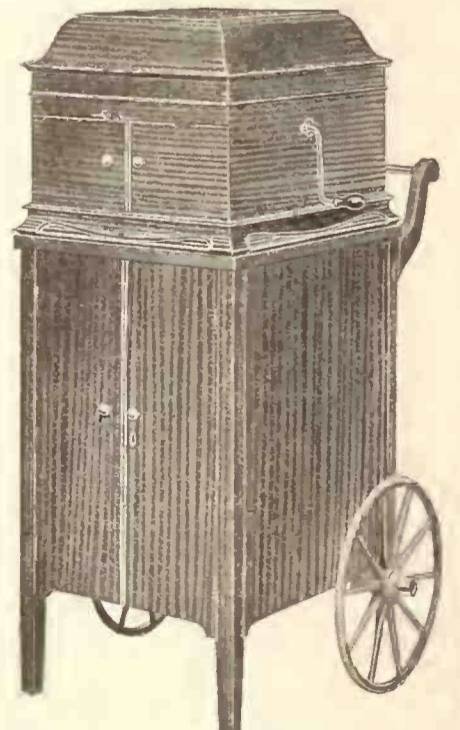

702—Mahogany, Golden, Fumed or Weathered Oak.—For Victrola IX. No. 701 for Old Victrola IX. 703 for Columbia Favorite. 704 for Edison A-80.

We also make many other styles of cabinets and will be glad to send our catalog for the asking

SCHLOSS BROTHERS

637-645 West 55th St.

Phone, Columbus 7947

NEW YORK CITY

**DE MOLL FEATURING THE VOCALION**

Washington Dealer Recently Exhibited Art Style Vocalions in Attractive Manner

WASHINGTON, D. C., August 9.—O. J. De Moll & Co., the well-known piano house at Twelfth and G streets, N. W., which also handles the Aeolian-Vocalion line of phonographs in this



A Section of the Vocalion Display

city, is planning to give this line an aggressive exploitation this fall, along lines which will materially increase the prestige of this phonograph in Washington.

A short while ago, O. J. De Moll & Co. presented an exhibit of art style Aeolian-Vocalions

which attracted visitors from a number of out-of-town points. This exhibit proved a signal success, and served to impress upon music lovers in this section that the Aeolian-Vocalion is a distinctive type of phonograph, embodying original constructional ideas, with unlimited possibilities as to cabinet design.

It is more than likely that O. J. De Moll & Co. will hold similar displays during the coming season, and accompany these exhibits by appropriate musical programs. This medium of publicity not only advertises the Aeolian-Vocalion in a high-class manner, but interests the public in the artistic side of the modern phonograph, as distinguished from its every-day purposes.

The accompanying photograph showing one section of the Aeolian-Vocalion art style exhibit will give some idea of the character of the instruments comprising this special display. The warerooms were attractively decorated during the period of the exhibition, and the newspaper publicity accorded the display called attention to the individuality of each style instrument exhibited.

ing on the manufacture of four styles, retailing at \$50, \$85, \$150 and \$200. Particular care was taken in selecting the cabinet designs for the "National Bluebird" machines, which embody several distinctive features, including record ejectors and castors.

John Feuerstein has opened a new piano and talking machine store in Sturgeon Bay, Wis.

**NEW SONORA CORP. WAREHOUSES**

Additional Space Badly Needed to Care for Rapidly Increasing Demands Upon That Concern—Used for Storage of Raw Material

In line with the "service first" policy of President George E. Brightson, Sonora Phonograph Corp., 57 Reade street, New York, plans were recently made whereby two five-story warehouses were leased, one on Duane street and the other on Broadway, these two places to be exclusively utilized for storage purposes. Here will be stored raw material (there is no chance to store finished machines) so that as the plans mature for more increases of factory output during the fall, everything will be in readiness for the work.

Constant watch over all phases of Sonora work, although helpful, has not as yet made any material decrease in the number of orders on hand for immediate delivery. In fact, as fast as the company creates additional output, the demand seems to grow in excess of the accomplishments, and as Mr. Brightson puts it: "It seems more of a problem to diminish orders than to increase the output."

The growth during this summer over the output of the same period last year is figured to be a trifle over 400 per cent. increase, and those familiar with the policies of merchandising back of the Sonora, know that this is all "cash business" sent in by the better class of business men. In fact, the Sonora Co. selects dealers much as a man selects a site for his home.

In addition to the foregoing two new warehouses in New York, the company has also leased additional space for the use of its Chicago branch.

The McLane & Quentrel Piano Co., of Copperhill, Tenn., is now installed in a large brick building there and is featuring a fine line of pianos, players, Victor Victrolas and small goods.

**DISPENSARY FOR EDISON PLANT**

It Is Completely Equipped with Competent Physician and Trained Nurse in Charge

A recent innovation at the plant of Thos. A. Edison, Inc., Orange, N. J., is the establishment of a medical and surgical dispensary to provide free treatment for employes who may be injured or taken sick while at work. The dispensary is in charge of Dr. A. Daniel, a well-known physician of East Orange, N. J., who is assisted by a trained nurse. No expense has been spared in equipping the plant hospital and every detail is most modern.

**TRADE VISITORS TO CHICAGO**

Among recent trade visitors to Chicago were J. G. Moore, Sioux City; J. M. Buck and wife, Lansing, Mich.; F. F. Pitzell, of the George B. Peck Dry Goods Co., Kansas City, Mo.; W. G. Haenschen, manager of the talking machine department of the Scruggs, Vandervoort & Barney Dry Goods Co., also Lorraine Merritt, of the same company, and Julius Beckman, A. D. Geissler, New York; A. Sonergan, of Block & Kuhl, Peoria, Ill.; A. O. Farlow, Doyle Furniture Co., Galesburgh, Ill.; W. Hanke, Gimbel Bros, Milwaukee, Wis., and J. B. Williams, of the Wurzburg Dry Goods Co., Grand Rapids, Mich.

**REPORTS HEALTHY TRADE DEMAND**

The Mutual Talking Machine Co., New York, reports a very healthy demand for the new "Mutual Special" machine, which it announced in last month's issue of The World. The members of the sale staff state that this machine is meeting with a ready sale throughout the country, and the returns received from the advertisement in the July World have made this company enthusiastic boomers of the drawing powers of advertising in The Talking Machine World. The "Mutual Special" is a floor machine, retailing at \$37.50, and playing all types of records.

**INTRODUCE "NATIONAL BLUEBIRD"**

The National Talking Machine Co., 118 East Twenty-eighth street, New York, has just placed on the market a new line of machines to be known as the "National Bluebird" talking machines. At present the company is concentrat-



## A Brand New Record Bulletin Fixture

**TEN DAYS' TRIAL TO THE FIRST 250 DEALERS WHO TAKE ADVANTAGE OF THIS OFFER**

**Holds 12 Monthly Bulletins**

*Every wing on this fixture lies perfectly flat*

**Here is what a UNIVERSAL will do for you**

- Sell your old records
- Increase sales of new records
- Improve the appearance of your show room
- Make it easy for your customers to see your lists

**Should be in every booth**

**Can be seen from any angle**

**Can be used for any standard size list**

**COLUMBIA VICTOR EDISON PATHÉ**

**Why we make you this offer?**

For two years our "Service Department" has been experimenting to get a fixture that will combine many advantages of wing display and make it easy for customers to see the lists at a distance.

This has been accomplished in the fixture illustrated. In order to place the fixture on the market, we are making a special introductory trial offer to the first 250 progressive dealers who are willing to seize every opportunity for increasing business. You run no risk in this fixture, because if you are not satisfied at the end of ten days you can send it back to us without expense.

*The trial number is limited*

**SO SIGN THE COUPON NOW** →

**HERE'S THE COUPON SEND IT ALONG TO-DAY**

Universal Fixture Corporation  
131 West 23d Street New York

Kindly send me, the cheapest way, one of your phonograph bulletin fixtures. If this is not satisfactory, I am to return it to you at your expense in ten days. If it does what you claim, I am to remit \$8.50 to you at the end of the ten days' trial.

Name .....

Address .....

## ORCHESTRA LEADER NOW MANAGER

W. Gus Haenschen, Well Known in St. Louis Musical Circles, Manager of Talking Machine Department of Vandervoort Music Salon—Sells Records Made by Own Orchestra

St. Louis, Mo., August 10.—The newest recruit to the talking machine selling game in St. Louis



W. Gus Haenschen

begins at the top. He is W. Gus Haenschen, manager of a popular orchestra bearing his name, but in the new capacity he is manager of the Victrola department of the Vandervoort Music Salon. He begins his work as an enthusiast and with full confidence that he can make it go. Already he has evidence that he has routed the "summer jinx" and has a good record to show for his first month. Another feature of Mr. Haenschen's business career is that he sells records made by himself. Recently he and a part of his orchestra had several records made by the Columbia personal service department and he has had quite a run on these. They are chiefly his own compositions, several of which have enjoyed good sale throughout the country. Local musical folk look upon Mr. Haenschen as an authority on questions of popular music and he is certain to have a considerable following in the record business because of this fact.

"I did not come into this business expecting to upset old methods," said Mr. Haenschen to The World correspondent. "I first intend to find myself and learn my bearings exactly in this new phase of musical work. I think that selling is a good deal of faith in your product, enthusiasm and 'pep' and those three things I have, along with some common sense. I have found that I enjoy the situation immensely and

that the fact that I am selling mechanical musical machines is not going to cause me to let up in my own music. Indeed, I find association with the records here rather encouraging to musical work." Mr. Haenschen is a native of St. Louis, a graduate of Washington University and an athlete.

## TO AMUSE PARALYSIS VICTIMS

Dr. Haven Emerson, Commissioner of Health for New York City, has issued an appeal for used talking machines for the benefit of sufferers from infantile paralysis. Hundreds of little patients are now in the hospitals, afflicted with the disease, and they have little or no means of amusement. Those who care to contribute either machines or records for this purpose have been requested to send their donations to Dr. Otto J. Wilson, of the Department of Hospitals, at Sixteenth street and the East River.

## SMOKING ROOM IN VICTOR STORE

SPRINGFIELD, MASS., August 9.—The Meekins, Packard & Wheat Co., Victor dealer, in this city, is planning to introduce a number of innovations this fall in the way of unusual ware-room furnishings and decorations. Last winter this company equipped one of their demonstration booths as a smoking room and a number of business men soon formed the habit of dropping in to hear the new Victor records, and enjoying a cigar at the same time. It is probable that similar innovations will be ready in time for the fall season.

## STEPHENS BILL HEARINGS

It has been announced that further hearings on the Stephens bill advocating price maintenance have been postponed until later in the year when Congress reconvenes. At that time the opposition will advance their arguments, subsequent to which the advocates of the measure will probably be heard in rebuttal.

## ANOTHER MODEL OF OUR 32 STYLES



Retail  
**\$35**

Oak or Mahogany. Size, 20 1/4 in. Wide. 20 1/2 in. Deep. 44 in. High. Double spring motor, 12-inch turntable, reversible tone arm, playing all records.

Write for our new eighty-two page catalog

The only one of its kind in America. It contains every essential part of a talking machine. It has over five hundred illustrations of parts and thirty-two different styles of phonographs.

**LUCKY 13 PHONOGRAPH CO.**  
3 East 12th Street, New York

## ATTRACTIVE COLUMBIA AD

The Columbia Co. carried a very attractive page advertisement in the July 22 issue of the Saturday Evening Post, entitled "The Stage of the World." The illustration used in this advertisement carried out the thought of the headline, and the text pointed out that "You have a stage of the world in your home if you own a Columbia Grafonola and Columbia records."

A. Brown, of the Good Value Bargain House, Baltimore, Md., was a caller at Columbia headquarters last week, with optimistic reports of the business outlook in his territory. Mr. Brown is making plans for a prosperous fall trade, which he states, is certain to come.

# Crescent



# Products

## Four New "CRESCENT" Models

We have four new and exclusive designs now ready for the fall season.

Is your stock up to date?

If not, ask for details now of the following distributors:

LOUIS WOLF & CO.  
221 4th Avenue  
New York City

LOUIS WOLF & CO.  
1319 Michigan Avenue  
Chicago, Ill.

CRESCENT SALES CO.  
Providence,  
R. I.

SCHILLING PIANO CO.  
112 W. 23d Street  
New York City

CRESCENT SALES CO.  
23 E. Jackson Blvd.  
Chicago, Ill.

Whatever your requirements may be—Phonographs, Equipments, Attachments, Accessories—"Crescent Products" will serve you best.

## Crescent Talking Machine Co.

89 CHAMBERS STREET

NEW YORK CITY

Style No. 12 .. .. \$75.00



## IMPORTANT CHANGE MADE IN CONDITIONAL SALES LAW

Recent Decision Rendered by the Court of Appeals Gives Buyer the Right to Claim Damages by Pleading Breach of Warranty—Sale of a Piano the Case in Question

On July 11 the Court of Appeals of the State of New York handed down a decision which constitutes an important change in the Conditional Sales Contract Law and which should be carefully regarded by piano dealers and other merchants transacting business under this law.

Briefly summarized, the Court of Appeals held "that in an action by the seller under a conditional sale agreement to reclaim the goods by replevin, the buyer may defend by pleading a breach of warranty by way of recoupment in diminution or extinction of the price."

The facts in this case are as follows: Peter C. Peuser sold to Elizabeth D. Marsh under conditional sale agreement a piano for \$260, of which \$25 was to be paid in merchandise, \$16 in cash and the balance in monthly installments of \$6 each. The defendant failed to pay the sum of \$141 with accrued interest. The plaintiff thereupon commenced an action in replevin to recover possession of the piano. The defendant set up the defense that relying upon certain warranties made by the plaintiff she had paid the sum of \$119, to apply on the purchase price and set up a counterclaim of \$200 damages sustained by her by reason of plaintiff's breach of warranty. The lower court held that this defense did not apply to this case, but the Court of Appeals reversed this decision and decided that such a defense could be interposed in this

action; thereby holding that conditional sales fall within the provision of the Uniform Sales Act.

In commenting upon this decision a number of prominent attorneys point out that it is directly contrary to what has heretofore been the law in this State.

Lorence & Harkavy, New York, attorneys for the New York Piano Manufacturers' Association, state that the courts held in two cases previously recited that the defense of breach of warranty was not available to a defendant under a conditional sale agreement until the full price agreed upon had been paid.

"The present decision of the Court of Appeals," states this firm, "makes absolutely no mention of these two previous decisions, and while it does not appear in the opinion of the court that these two cases are expressly overruled, it is impossible to reconcile such a decision and consequently, in our opinion, these two cases are overruled."

"This will seriously affect future actions of this nature and undoubtedly purchasers of pianos and other articles under conditional sales contracts will attempt to defeat such actions or cut down balances due by means of this defense. It will simply mean that greater care will have to be exercised by dealers and salesmen in making statements to customers at the time contracts are signed."

simply effervescent with optimism and the joy of life. I mean things like Schubert's 'Hark, Hark, the Lark' and 'Who is Sylvia'—things like 'The Heavens Are Telling the Glory of God,' from Haydn's 'Creation'; the first movement of Beethoven's 'Seventh Symphony,' or the 'Alla Danza Tedesca,' from his string quartet Op. 130. And let me recommend such waltzes as Waldteufel's 'Estudiantina,' Johann Strauss' 'Thousand and One Nights' and 'Beautiful Blue Danube.'

Mr. Schaufler closes the article with "Lastly, as a provider of change of air, certain music is almost as good as the wishing mat in the fairy story."

Talking machine dealers might utilize Mr. Schaufler's suggestions to excellent advantage and make a special campaign for record sales among their patrons who are indisposed or "under the weather."

## UNIT CONSTRUCTION CO. FILES SUIT

PHILADELPHIA, PA., August 11.—The Unit Construction Co., Thirty-first and Chestnut streets, of this city, makers of Unico demonstrating rooms, announced to-day that they had filed action in the United States Court, Eastern District of Pennsylvania, against the Huskey Manufacturing Co., of the same city, claiming infringement of design and construction of Unico demonstrating rooms, as well as infringement of literature.

This company also asks for an injunction restraining the defendant from using the design, construction or literature of the plaintiff, together with an accounting and damages.

## RECORDS CHARM THE BOVINE SOUL

Denver Dairyman Installs Talking Machine in Barn to Increase Cow's Yield of Milk

DENVER, COL., August 10.—Ragtime music at milking time is an innovation on the dairy farm of W. W. Wilcox, just east of Denver. He says the herd shows its appreciation by yielding an increased amount of lacteal fluid. He recently installed a phonograph in one end of the barn.

"It serves two purposes," explained Mr. Wilcox, a former Chicago man. "It keeps the cows quiet, for the cow has an aesthetic, musical temperament; it keeps the men from talking and forgetting their work. This constant interruption from talking among the men interferes with the flow of milk and lessens the quantity the cow would yield otherwise."

"The music charms and soothes the bovine soul as nothing else can, and under such conditions she will allow even an ordinary milker a greatly increased quantity."

"I know that she pays for the music."

## INCREASE CAPITAL STOCK

Frank E. Bolway & Sons, Inc., of Syracuse, N. Y., have certified to an increase in capital stock from \$100,000 to \$125,000.

## THE HEALING POWER OF MUSIC

Some New and Interesting Views on the Effect of Music Upon the Mental and Spiritual Being—How Young David Played the Harp for King Saul—Most Effective Music

Robert Haven Schaufler, in a recent issue of the Good Housekeeping magazine, says in part that "most of us suffer more mentally and spiritually than we do physically. Headache is bad enough, but a heartache is worse. A month of the grippe is by no means as difficult to bear as a month of the blues."

"Since King Saul used to have young David come in with a harp to drive away his evil spirit, the healing power of music has been known and deliberately used by an occasional wise man here and there."

Then in talking of the effect of music on everyone, he makes one proviso, "Therefore, I do not offer prescriptions which follow with full confidence that they will all be helpful to everybody, but simply in the hope of providing a starting point for each one to work out his own individual system of musical therapeutics."

For instance, he says: "What one needs as an antidote for morbidity is healthy, sunlit music like 'The Lass with the Delicate Air,' composed by Dr. Arne and sung by an artist like Sembrich; Schubert's song, 'The Trout'; the variations from the Beethoven 'Sonata in A flat, Opus 26'; 'The Sandman,' by Brahms; or Boccherini's famous 'Minuet.'

"These pieces, however, and those to be suggested later, are put down with many misgivings and mental reservations. It is dangerous to generalize about the effect of any particular piece upon humanity, because the nature of music is to be 'all things to all men,' to call up a different picture or idea in the mind of each one who hears it."

"For effacing a disagreeable impression, with completeness and dispatch, there is nothing quite so effective as well-selected music well performed. Any of the following pieces should produce the desired results: Schubert's 'Unfinished Symphony,' his 'Linden Tree,' as sung by a singer like Witherspoon; Macdowell's 'To a Wild Rose' and 'Starlight,' 'Angels Ever Bright and Fair,' by Handel; Chopin's 'Ballade' in A flat; and these things by Schumann: 'A minor Concerto,' 'Scenes from Childhood,' 'The Lotus Flower' and the 'Symphonic Etudes.'

"As another antidote for the blues, sometimes it is better to hear unlaughing music which is

## Here is a Different Line

Ready for Delivery

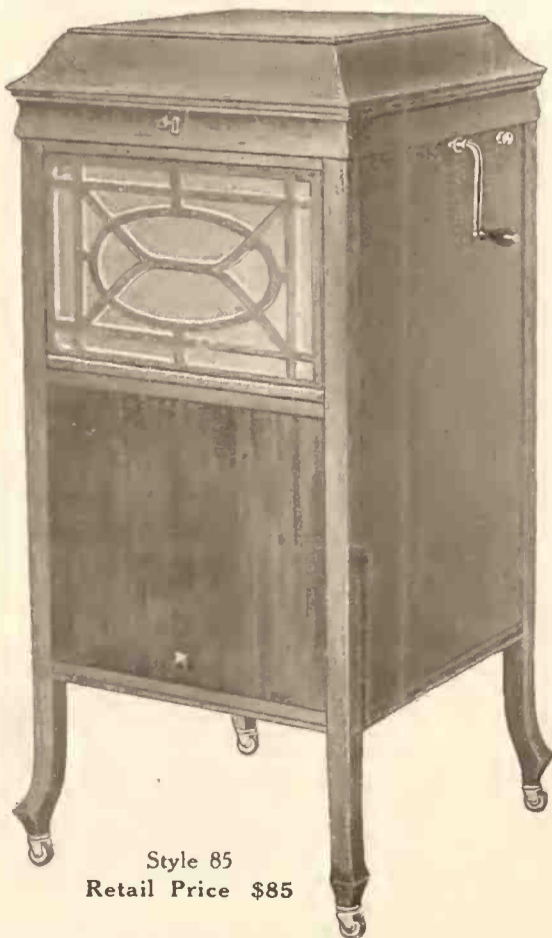

Style 85  
Retail Price \$85

The "National Bluebird" Machines represent the last word in talking machine construction. The cabinets are distinctive and high-grade, genuine mahogany and oak being used.

All "National Bluebird" machines play all types of records without any attachment. Equipped with the finest motor, tone-arm, sound-box and tone modifier. Floor machines have new record ejectors and casters.

Retail from \$50 to \$200

Write for Dealer Proposition

National Talking Machine Company, Inc., 118 East 28th St., New York

### WINS PRAISE FROM ARTISTS

Manophone Announced Last Month by James Manoil Co. Wins Quick Approval—James Manoil Returns from Trip—New Illustrated Catalog to Be Out August 20

According to reports from the executive offices of the James Manoil Co., 60 Broadway, New York, the announcement of the Manophone which was made exclusively in *The World* last month, was received with much enthusiasm by talking machine dealers all over the country. Although a new product, the Manophone has also won the quick approval of several well-known artists who have strongly endorsed it. Among these is Miss Lucile Lawrance, a soprano prima donna of note, and her endorsement of the Manophone which appears on another page of this issue is considered by the officials of the company as a splendid tribute. She was recently one of the soloists at the entertainment of the National Open Air Festival at the Polo Grounds, New York, when Verdi's "Requiem Mass" was sung by nearly 1,000 voices.

James Manoil, president of the company, arrived home the early part of last week from an automobile trip to Chicago, where he found a wave of prosperity throughout the country which he visited. "From what I could see," he said to a *World* representative this week, "we have every occasion to feel satisfied that there will be big business during the coming fall. We have had a very satisfactory demand for the Manophone, which, although just placed on the market, has appealed to many dealers owing to its several individual characteristics, and its exceptional tone quality. We are manufacturing a machine notable for its construction and workmanship and artistic cabinet design as well as containing these individual features."

The new Manophone catalog will be ready for distribution by August 20. According to B. Abrams, vice-president and general manager of the company, no expense has been spared in making this booklet one of the most artistic

which has ever appeared in the talking machine field. It will contain the various styles of the Manophone illustrated by the use of reproductions of wash drawings, which have been completed with the greatest care.

### LARGE INCREASE IN VOCALION SALES

NEW ORLEANS, LA., August 10.—Manager H. L. O'Brian, of the D. H. Holmes Co., states that the Aeolian-Vocalion department of the store has shown a 65 per cent. increase in sales during the past month. The firm has recently been featuring a series of advertisements concerning the desirability of the Vocalion as a means of entertainment on yachts and in summer camps and many good sales have resulted from this seasonable publicity.

### SECURES AGENCY FOR PATHEPHONE

STOCKTON, CAL., August 10.—The Pedersen Music Co. has been given the exclusive agency in this territory for the Pathé Pathephone. Henry Burgee, formerly with the Pathephone Shop of Chicago, and now connected with the local Pathé headquarters in San Francisco, who recently visited the Pedersen store, states that he believes the outlook for the Pathé line in this territory for the fall and winter to be exceptionally promising.

### CHANGE DATE OF OUTING

On page twenty-five of *The World* this month is an item regarding the annual outing of The Talking Machine Men, Inc., at Rye Beach, the date of the outing is given as September 6. As we go to press it is announced by the association officials that the outing date has been changed to September 12, and that it will positively be held on that day.

The regular monthly meeting of The Talking Machine Men, Inc., will be held at Keen's Chop House on Wednesday, August 16, at 1 p. m., when the final details of the outing will be arranged and other matters of interest discussed.

### EFFECTIVE AEOLIAN PUBLICITY

Artistic and Well-Written Advertisement Features the Aeolian-Vocalion

"Music as Wonderful as Mother Love" was the heading of an unusually artistic advertisement used by the Aeolian Co. in the Sunday newspapers to feature the Aeolian-Vocalion. An illustration pertinent to this heading was a feature of the advertisement, which read:

"Sweet and low! . . . tenderly caressing the spirit like a gentle, soft-skinned hand—a fragile, pastel-tinted thing of dreams, yet surging with a wonderment of unquestioning love—the lullaby!

"Perhaps you have sat enthralled as such a fascinating melody, glowing with a strange, almost celestial beauty, sighed from beneath the bow of a master violinist—or breathed softly from the lips of a gifted, geniused singer. All the joy of such an experience you may have time and time again.

"For the Aeolian-Vocalion, the wonderful new phonograph, searches out from every record its last subtlety of sound—finds, even, all the delicate, elusive harmony of the music of mother love and gives it back to stir your soul like the gentle, sweet tone of distant chimes, or the hushed vox humana of a great church organ.

"A triumph of musical instrument making, indeed—this great new phonograph which voices perfectly the pale, appealing delicacy of the lullaby, or sounds truly the bold, ringing imperiousness of a fanfare of trumpets.

"As the Vocalion gives forth its glories of music, you may take the Graduala—the remarkable Vocalion expression control—and by instinctive pressure touch each phrase with a tinge of your own personality—impress each tone in the mold of your own music feeling.

"This is the real wonder of the new phonograph—it gives you all the pleasure of listening to glorious music, and the supreme joy of making music—the prime joy of creative musicianship."

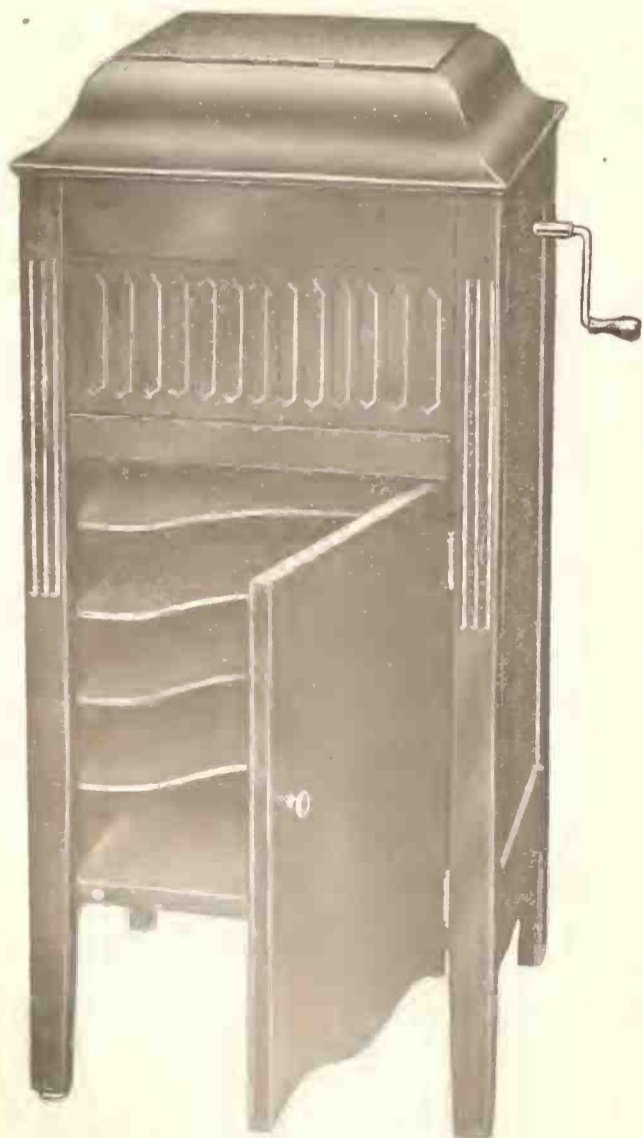

SUPERTONE, No. 5  
18 x 18 x 36    Retails, \$50—\$75

## THE "BIG 3" LEADERS OF

# Supertone

TRADE MARK

## Talking Machines

NOW READY FOR DELIVERY

It has taken us months to perfect the SUPERTONE line and you can rest assured that the SUPERTONE talking machine gives you the most profits.

Every machine is up to the quality represented, and we invite comparison on any of our models with machines costing much more.

Notice the illustrations and remember that these machines are all equipped with heavy double spring worm gear motors, Universal tone arms, etc., and beautifully finished cabinets.

Write for special wholesale prices  
and get ready for the fall rush.

SUPERTONE TALKING MACHINE CO.  
10 WEST 20th STREET    NEW YORK



SUPERTONE, No. 2  
16 x 16 x 8 1/4    Retails, \$15—\$25

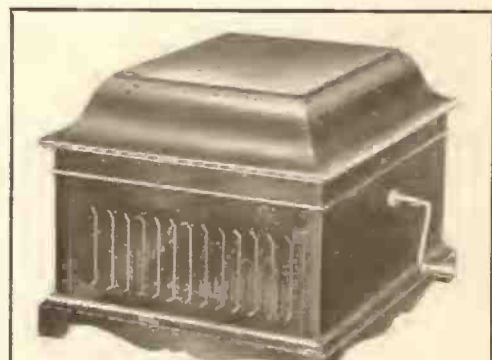

SUPERTONE, No. 4  
16 3/4 x 20 1/2 x 14 3/4    Retails, \$30—\$50



**TRUTH IN ADVERTISING PAYS**

Snappy Letter on This Subject Sent Out by a Chicago Sales Manager—Crooked Dollar Gained To-day Means Loss of Ten Honest Dollars To-morrow—Building a Reputation

The following weekly bulletin was issued recently by the sales manager of one of Chicago's most progressive retail piano houses, which handles talking machines, and it offers a real sermon on the matter of truth in advertising and selling. The bulletin says in its introduction: "We are developing a very large force of fighters for business. The thing that is continually in my mind is: Can we develop this force as quickly as we are developing and still develop the right working principles in the minds of these men and women?" The following article gives this subject proper treatment:

**The Truth in Advertising**

"Listen, young man! The cleverest man in the world is the man that tells the truth, and tells it all the time, not occasionally.

"Sometimes you can profit by a lie, but it is like dodging bullets; you never know when you are going to get hurt.

"Lying is a game. Sometimes it is a very exciting game. But it is essentially gambling. And gambling, any sort of gambling, is not business.

"The fundamental laws of business are just as accurate and as well established as the principles of geometry.

"It is hard to see this, for our visual range is limited. Most of us can see the crooked dollar coming to-day, but not the ten straight dollars it is going to lose us to-morrow.

"Real business success is cumulative. It grows like a snowball. And the one thing that makes it keep us growing, even while we sleep, is our persistent truthfulness and dependableness.

"If you put an advertisement in the paper announcing goods worth \$5 for sale at \$2, and if the people come and buy, and find out the stuff is not worth 10 cents, you may make a one-day's gain, but you have alienated a lot of indignant customers and have started to saw away the posts that sustain your reputation.

"If you have a store rented for a week only and propose to conduct a sacrifice sale of goods that will make everybody disgusted who buys

them, then perhaps you may lie with a high hand and a stretched-out hand.

"But if you are in the town to stay, and want regular, returning, increasing, satisfied, friendly customers, it will pay you to stick to the old-fashioned truth.

"Exaggeration is lying. It does not take long for the people in the community to get the habit of discounting 25 per cent. of all you say.

"If you continually overstate and vociferate, you must keep on getting louder until you soon become incoherent.

"But if you habitually state only what is soberly, honestly true, by and by everything you say will be always above par.

"A man's repute for truthfulness is as much a part of his capital as are his store and stock; so much so that he can raise money on it.

"As civilization progresses, business becomes more and more an affair of credit and trust. The very foundation of big business is trustworthiness. Therefore, if you are ever going to get beyond the peanut-stand and push-cart stage of merchandise you must establish a basis of dependableness.

"There is not one thing in this world, young man, that can be of as much value to you as building a reputation such that men will say, 'Your word is as good as your bond.'

"It is well to be clever and keen and Johnny-on-the-spot; it is well to look out for number one and to know a good bargain, but best of all is to have the world say to you:

"Whatever that man says can be absolutely relied upon."

**CHICAGO'S SIX BEST SELLERS**

CHICAGO, ILL., August 11.—The six best Columbia record sellers here this month were "The Murray Walk" and "The Girl on the Magazine," "Babes in the Wood" and "Love Me at Twilight," "There's a Quaker Down in Quaker Town" and "When It's Springtime in Killarney," "Pua Mohala" and "Hawaiian Melody," "Simple Confession" and "Hearts and Flowers" and "Where Did Robinson Crusoe Go with Friday on Saturday Night" and "I'm Going Back Home and Have a Wonderful Time."

In the Pathé library the six best sellers were "Christmas Valse" and "La Marseillaise," "Thou Brilliant Bird" and "The Last Rose of Summer," "Silver Threads Among the Gold" and "Come Back to Erin," "My Automobile" and "Gootman Is a Hootman Now," "Honky Tonky" and "La Confession," and "Wake Up, America" and "Georgia Moon."

The August popular sellers of the Victor were "Do What Your Mother Did (I'll Do the Same as Your Dad)" and "When the Sun Goes Down in Romany," "My Mother's Rosary" and "Yaaka Hula Hickey Dula," "Uncle Tom One-Step" and "Arrah, Go On, I'm Gonna Go Back to Oregon," "In the Gloaming" and "Supplication," "Song to Hawaii" and "Hawaiian Hula Melody" and "Lullaby from Erminie."

The following were the popular records offered by the Edison Co.: "American Fantasie" and "National Emblem March," "Lo! Hear the Gentle Lark" and "Where'er You Walk," "On

the Hoko Moko Isle" and "Yaaka Hula Hickey Dula," "My Bonnie, Bonnie Jean" and "Nanny I Have Never Loved Another Girl Like You," "Kangaroo Hop" and "Setting the Pace," and "Home to Our Mountain" and "Praise Ye."

**PLEASED AT BUSINESS PROSPECTS**

Fred P. Oliver, vice-president and general manager of the Blackman Talking Machine Co., New York, Victor distributor, returned recently from a visit to the company's dealers up-State. He was greatly pleased to learn that the Victor dealers are closing an excellent summer business, and judging from the plans now under way, the coming fall will be a record-breaking season in every respect.

Boone Medford and J. E. Massie, of Waynesville, N. C., have built up a splendid business in Columbia Grafonolas, and are carrying a full line of machines and records.

The American Graphophone Co. has declared the regular quarterly dividend of 1 3/4 per cent. on its preferred stock, payable August 15 to stock of record August first.



The Phonolamp

**SOME  
DESIRABLE  
TERRITORY  
YET OPEN**

**Electric  
Phonograph Co.**

29 WEST 34th STREET  
NEW YORK

Factory: Mount Vernon, N. Y.



**Mellotone III**  
SIZE 17 x 19 x 12 1/2 INCHES

Plays *four* ten-inch records at one winding. Plays *all* makes of disc records. Handsome in finish and appearance. Beautiful toned.

List Price **\$15.00**

Maximum price to dealers \$10.00.  
Discounts on application.

*The Melophone*  
TALKING MACHINE  
COMPANY, INC.,  
376-378-380 LAFAYETTE STREET  
CITY OF NEW YORK, N.Y.

**Closing Out Sale**

*All of Our Six Inch Vertical  
Cut Records*

We have on hand 100,000 6-inch vertical cut records including operatic, vocal and instrumental selections by many well known artists.

As we have discontinued the manufacture of this type of record and are now concentrating on the Emerson Universal cut 10-cent and 25-cent Double-discs, we will dispose of any or part of this lot, minimum quantity 1000 at - - - - -

**4<sup>c</sup>**  
each

Address

**Emerson Phonograph Company**  
3 West 35th Street NEW YORK  
Attention Mr. Bernard D. Colin



# Pathé

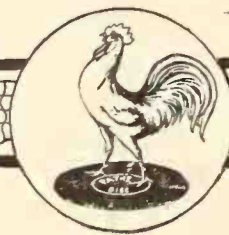

## Pathé is Making



### Pathé

**Something  
New—Different—Better!**

The Pathé Dealer travels an easy road!

Of course, he has Pathé Prestige in both the moving picture and phonograph fields, but his main advantage lies in the exclusive and unique excellence of the Pathé product.

The Pathé Pathephone, with its all-wood "Violin" sound chamber, is more than a mere talking machine. It is a fine musical instrument entirely in a class of its own.

Nor is there any argument or comparison where Pathé records are concerned.

Such **TONE — SOUND — VOLUME** — have never been equalled.

Pathé records have longer sound waves than ordinary records.

They are played with a polished ball-shaped jewel (a genuine sapphire) instead of a sharp-pointed destructive needle.

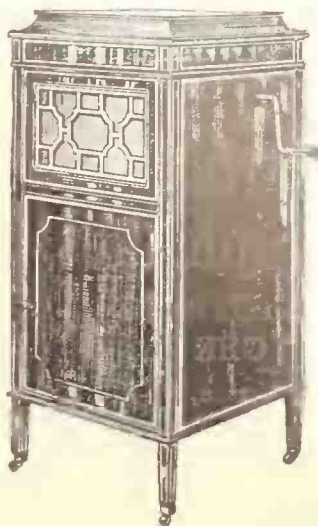

#### Model No. 225

##### Specifications

Sheraton Inlaid Cabinet.  
Finished in hand rubbed dull antique mahogany.  
Size 22 in. Wide, 23 in. Deep, and 48 in. High.  
Perfect Tone Control Device.  
Six Record Albums furnished.  
Automatic start and stop device.  
Special long running Motor.  
Equipped to play all makes of disc records.  
All exposed Metal Parts Gold Plated.

\$225.00

Get aboard t  
The time w  
progressive

We have  
Don

## PATHÉ FRÈRES

29 WEST 38th S



# Pathé

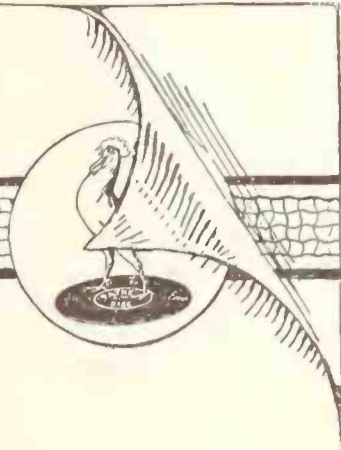

us Strides

**Records**  
**Like These Sell Themselves**

The Pathé library is noted for its collection of famous American and European operatic stars, symphony orchestras, soloists, bands, etc. Many of these records by the world's best talent are exclusive with Pathé.

Many Pathé European records are by celebrated artists who have never been in America.

All this gives the Pathé Dealer a never-failing means of stimulating new business. **HE HAS SOMETHING THE OTHER FELLOW LACKS!**

The Pathé Dealers' profit is big. Supreme quality coupled with good value enable him to speedily build up a solid, substantial business.

All Pathé Discs are double-faced! Even the finest operatic records: (65c. to \$4.00).

Pathé Patephones, equipped to play any make of disc record, \$25.00 to \$225.00.

Wagon now!  
 for the live  
 look ahead!  
 proposition!  
 NOW

**PHONOGRAPH CO.**  
 NEW YORK, N. Y.

**Model No. 75**  
**Specifications**

Finished in Mahogany, also Weathered, Golden or Fumed Oak.  
 Size 18 in. Wide, 19 in. Deep, and 42 in. High.  
 Perfect Tone Control Device.  
 Commodious shelf space for disc records.  
 Equipped to play all makes of disc records.

\$75.00



## WORLD'S CLASSIFIED ADVERTISING

Any member of the trade may forward to this office a "Situation" advertisement intended for this Department to occupy a space of four lines, agate measure, and it will be inserted free. Replies will also be forwarded without cost. Additional space will be at the rate of 25c. per line. If bold faced type is desired the cost of same will be 25c. per line. Business opportunities 25c. per line.

**FACTORY SUPERINTENDENT WISHES POSITION**—Thoroughly experienced executive, is open to offers from the trade. Has increased production and decreased cost in present position. Tone arm, sound box and motor expert. Address "Box 346," care The Talking Machine World, 373 Fourth Ave., New York.

**WANTED**—One of the oldest record companies in the country has positions open to a thoroughly competent lateral-cut recorder; also a plastic man in its pressing plant. Replies will be considered confidential and should state qualifications, experience and terms. Address "S. S. M.," care The Talking Machine World, 373 Fourth Ave., New York City.

**WHOLESALE VICTOR distributor needs talking machine salesmen.** Address "L. M. R.," care The Talking Machine World, 373 Fourth Ave., New York City.

**A YOUNG INVENTOR seeks engagement.** Desires no pay whatever until ability has been thoroughly tested and proven. Letters only. Joseph Brewer, 161 East 122d St., New York.

**WANTED**—Expert motor mechanic. Must have worked with a motor manufacturer and understand fine points of assembling, elimination of noise, etc. State full particulars. Address "Box No. 352," care of The Talking Machine World, 373 Fourth Ave., New York.

**MANUFACTURERS, Jobbers, Retailers and every description of Talking Machine dealers:** I will pay cash for Reminders of any quantity. We are in the market for complete bankrupt stocks and new records of all descriptions. When any part of your stock is for sale, for quick action, write J. I. Williams Book Co., 533 Main St., Worcester, Mass.

**MR. MANUFACTURERS**—An all-around experimental inventor of improvements and thorough practical knowledge with a ten-year experience in the talking machine manufacturing line, desires position to take charge of a talking machine manufacturing plant with reliable firm. Will go anywhere. Best of references. Address "Box 340," care The Talking Machine World, 373 Fourth Ave., New York.

**SITUATION WANTED**—Selling ability backed by energy and originality. Young man, 24, three years' experience in all branches, desires connection anywhere. Address "Box 341," care The Talking Machine World, 373 Fourth Ave., New York City.

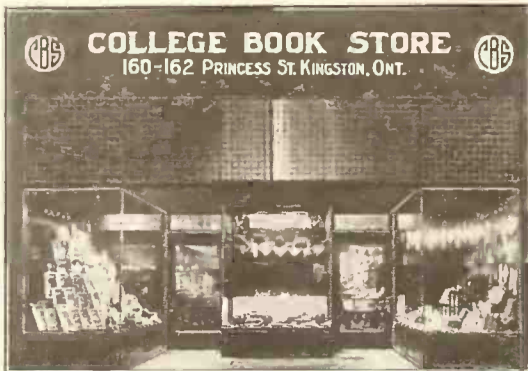

## WANTED

A partner in this business for Talking Machine Department. The finest opening in Canada or the United States for Talking Machine business. Can secure agency for any of the leading machines.

Kingston is located at the junction of Lake Ontario and the St. Lawrence and Rideau rivers, at the head of the Thousand Islands. Population 23,000, with rich surrounding country trade; reached by three railroads and steamboats. University with attendance of 1,800 and Royal Military College (Canada's West Point). Good manufacturing center, with the largest locomotive works in Canada.

Store is located in the heart of the shopping center with best display windows in the city, modern copper front with tiled entrance. Two floors each 60 x 30 x 16. Second floor reached by wide center stairway at rear of first floor, can be used exclusively for talking machine business. Ample room for five large demonstration booths and large recital hall. Beautifully lighted with large front and side windows and skylight. Hardwood floor.

Book and stationery business increased in 1915, 43 per cent. First six months of 1916 increased 68 per cent. over corresponding six months of 1915.

Partner must have thorough knowledge of the Talking Machine business.

Address, with full particulars,  
COLLEGE BOOK STORE,  
Kingston, Ont.

**POSITION WANTED**—Energetic young man, capable of managing Victrola department, wishes position in the East. Address "Box 343," care The Talking Machine World, 373 Fourth Ave., New York City.

**MECHANICAL ENGINEER** desires position as supervisor of motor, tone arm, sound box production in a plant in New York or nearby territory. Thoroughly experienced. A1 references. Address "Box 344," care The Talking Machine World, 373 Fourth Ave., New York City.

**CABINET SUPERINTENDENT** desires to make a change. Now connected with one of the largest phonograph manufacturers in this country. Have had twenty-five years' practical cabinet experience, and thoroughly understand cabinet manufacturing, buying and designing in every detail. Address "Competent," care The Talking Machine World, 373 Fourth Ave., New York City.

**WANTED GOOD SALESMAN**—Competent to manage small goods department in music store. Permanent position. Only an experienced man of about 25 to 30 years old will be considered. Goldsmith's Music Store, 69 South High St., Columbus, O.

**SALESMAN WANTS POSITION**—I am 30 years of age and have seven years' experience as a salesman. Can give the best of references. Address "Box 345," care The Talking Machine World, 373 Fourth Ave., New York City.

**VICTOR MAN** who thoroughly understands the retail business from every angle desires to join sales staff of Victor distributor. First-class references. Address "Box 348," care The Talking Machine World, 373 Fourth Ave., New York City.

**HIGH-CLASS aggressive man** who has had entire charge of Victor distributors, wholesale and retail business, for several years, desires to locate with live concern. Best of references. Address "High Class," care The Talking Machine World, 373 Fourth Ave., New York.

**POSITION WANTED**—Young man, 26, traveled in South America for talking machine concern, desires position. Speaks Portuguese, Spanish, Bohemian, German and English. Address "Box 342," care The Talking Machine World, 373 Fourth Ave., New York City.

**POSITION WANTED** as manager of talking machine department. Five years with present employer but want to make change. Age 33, married. Best references. Thoroughly familiar with New York City and Chicago trade. Address "Box 349," care The Talking Machine World, 373 Fourth Ave., New York City.

**FIRST-CLASS varnish foreman** wishes position with phonograph company manufacturing a high-grade talking machine. "Box 351," care The Talking Machine World, 373 Fourth Ave., New York City.

**MANAGER DEPARTMENT**—Reliable business getter, good ideas, no humbug, experienced sales manager and executive. Good appearance, education, and address; age 27. Can do business with best of trade. Prefer coast or western city. Want permanent position. "Box 350," care The Talking Machine World, 373 Fourth Ave., New York.

**WANTED**—Young man to assist in wholesale Victor department. State age, experience and salary expected. Send reply to "Box 338," care The Talking Machine World, 373 Fourth Ave., New York City.

**POSITION WANTED**—Experienced young woman, capable of handling talking machine department, desires to make change. A-1 references. Address "Box 339," care The Talking Machine World, 373 Fourth Ave., New York.

**POSITION WANTED** by a young man who is thoroughly acquainted in the Victor products; desires position as inside salesman. Capable of furnishing first-class reference. Address "Box 337," care The Talking Machine World, 373 Fourth Ave., New York City.

**POSITION WANTED**—Buyer or inspector for your Cabinet Department by an experienced furniture man, who understands woodwork construction. Highest reference. "Box 334," care The Talking Machine World, 373 Fourth Ave., New York.

## FOR SALE

In prosperous and growing town, 50,000 population, exclusive Edison business for sale. Opportunity unsurpassed. "Box 347," care The Talking Machine World, 373 Fourth Ave., New York City.

## MOTORS FOR SALE

We offer for immediate shipment three thousand single spring motors, complete, with ten-inch turntables and all fittings. Address "A. T. 10," care The Talking Machine World, 220 South State St., Chicago, Ill.

## Manufacturers, Attention!

Advertiser having patented a simple attachment for talking machine of the "Disc" type, which permits the making of amateur records thereon, wishes to dispose of same outright, or to arrange for manufacturing on a royalty or profit-sharing basis. Article can be manufactured at low cost. Demonstration in New York City by appointment. Address "X. Y. Z.," care The Talking Machine World, 373 Fourth Avenue, New York.

## PLEASED WITH CONDITIONS

W. C. Fuhri, United States manager of the Columbia Co., and A. C. Erisman, New England district manager, made a trip through this territory recently visiting the Columbia wholesale centers and a number of the company's dealers. Mr. Fuhri was well pleased with the conditions he found in the New England States, and the dealers in turn were delighted to learn that the Columbia Co.'s increased manufacturing facilities will be reflected in a steady increase in the machine and record output.

Eli Farney, director of the Ladies' Band, at Hutchinson, Kan., and J. J. Farney have purchased the Edison Shop at 18 North Main street, from E. J. Hollister.

## 216 BARGAINS for Quick Cash Buyer

Well known manufacturers will sell 216 remaining talking machines of a model which has just been discontinued. Retail for \$30.00. Mahogany finished, covered cabinet, 14 x 17 x 20 inches. Double spring worm driven motor with 12-inch turntable and universal tone arm. Every machine in perfect condition. Communicate by LETTER only with

G. W. HERZIG

Factory Representative

142 West 26th Street  
New York City



Size  
16 in. x 17 in. x 37 in.

Live Dealers Are Taking Advantage of Our Special Discounts.

Are You One of Them?  
If Not, Get Busy NOW.

**The Mutual Special**  
**\$37.50 (Retail)**

Cabinet, Mahogany or Oak, hand carved, first-class finish. Equipped with a strong double Spring Worm-gear Motor, Universal Tone-arm, and will play all records without any attachments.

Write for circular on our No. 1 and No. 2 Improved Tone Arms. Shipments ready September 15th.

The Mutual Talking Machine Co., Inc., 145 W. 45th St., New York

**DEATH OF HENRY D. KING**

Manager of Personal Record and Professional Departments of the Columbia Co., Passed Away in Branford, Conn., on August 10

Henry D. King, manager of the personal record and professional departments of the Columbia Graphophone Co., New York, died on



Henry D. King

August 10 at the home of Mrs. King's family, at Branford, Conn.

Mr. King had been ill for the past five months but it was thought that he was convalescing at the time he left his home in Brooklyn for Branford. He suffered a relapse, however, and died suddenly on Thursday.

During the comparatively short while that Mr. King had been associated with the Colum-

bia Co., he had won the esteem and friendship of his associates in all departments. Few men showed greater interest in their work than Mr. King, for he never seemed to consider time or effort in the discharge of his duties.

The remarkable success of the Columbia Co.'s personal record and professional departments may be attributed in a large measure to Mr. King's indefatigable efforts, coupled with his pleasing personality and wide acquaintance in the artistic and musical professions.

Mr. King was also well known in insurance circles in this city, having occupied the position of vice-president of the National Security Co. prior to joining the staff of the Columbia Graphophone Co.

The funeral was held on Saturday afternoon from Branford, quite a number of the Columbia Co.'s executives being present. Among the many floral offerings was a beautiful wreath from the employes of the Columbia Co.

**A. T. DOTY APPOINTED MANAGER**

A. T. Doty has been appointed manager of the sales department of the Arion Manufacturing Co., 250 Devonshire street, Boston, Mass., makers of the Arionola. Mr. Doty is an experienced and widely known talking machine man.

**RETURNS TO HIS DESK**

R. G. Craig, head of the efficiency department of the New York Talking Machine Co., New York, Victor distributor, returned to his desk Monday after a two weeks' rest, upon which he conceived a number of new ideas which will be introduced to the company's dealers in the near future.

**SECURES COLUMBIA AGENCY**

The Heidelberg Furniture Co., Jackson, Miss., has secured the agency for the Columbia Gramophones and records in that city. Ben Martin is in charge of the new department.

**SWINDLERS BUSY IN NEW YORK**

Have Numerous High-Priced Machines Sent to One Address After Making Small Payment, and Then Re-Sell Them Before Second Payment Is Collected

It has been reported to The World that a band of swindlers has been operating among talking machine dealers in New York City recently and causing some considerable loss. The members of the band are purchasing Victrolas XIV and XVI on instalments, paying \$10 down and having as many as half a dozen instruments shipped to one address in a single day. The Victrolas are re-sold soon after delivery and the fraud is not discovered until an effort is made to get the second payment. Dealers are warned to be particularly careful in investigating the standing and references of those at present buying the two types of machines named.

**CO-OPERATION IN SCHOOL WORK**

The value of reaching the young people is being taken into really practical account, to judge by the embossed announcement-invitation recently issued by I. Davega, Jr., Inc., of New York City, the significant part of which reads "We take pleasure in announcing that, beginning with September 1, we will have a separate Educational Victrola Department, in charge of Miss H. M. Moses, who is well known in school and educational work."

**NEW EDISON STORE**

L. H. Walter, of the Walter Piano Co., Hillsboro, Tex., has leased the newly finished Interurban Building, where he will carry a complete line of pianos, sheet music, small goods and Edison Diamond Disc phonographs.

The Pettit Jewelry store, at Downs, Kan., has opened a department devoted to the Pathé Pathephone.

**LONG CABINETS**

WELL MADE THROUGHOUT

These With Others Comprise the



D 77

Mahogany, Golden Oak, Fumed Oak, Weathered Oak. Height 34 in. Top 19 1/4 x 22 1/2 in. Holds 192 12-in. Records. For Victrolas VIII and IX, and Columbia "Favorite." No countersunk holes in top. Sliding Record Shelf. Average weight, crated, 80 lbs.



D 79

Mahogany, Golden Oak, Fumed Oak, Weathered Oak. Height 34 in. Top 19 1/4 x 22 1/2 in. Holds 192 12-in. Records. For Victrolas VIII and IX, and Columbia "Favorite." No countersunk holes in top. Sliding Record Shelf. Average weight, crated, 85 lbs.

ELEGANTLY FINISHED

Most Complete Line of Record Cabinets

PROMPT DELIVERIES ON ALL ORDERS

Write for Illustrated Catalogue

**THE GEO. A. LONG CABINET CO., HANOVER, PA.**



Patented Feb. 4, 1916  
Models 1 and 3 with  
Wood Panel Doors;  
Quartered Oak and  
Mahogany

OGDEN SECTIONAL CABINET CO., Lynchburg, Va.

## A SECTIONAL Cabinet

- Adds dignity to your store.
- Increases your sales.
- Locates any record instantly.
- Adapted to any space.
- Fits your requirements.
- Add sections when needed.
- Helps you to grow.
- Files records in smallest space.
- A patented and exclusive device.
- The best filing "Sales System."
- Unconditionally guaranteed to you.
- List of Jobbers and a "Modern Method of Filing" mailed upon request.

### SECURING RAW MATERIALS

How the Difficulty in This Field Was Overcome by Horace Sheble, President of the Domestic Talking Machine Corporation

PHILADELPHIA, PA., August 10.—Horace Sheble, president of the Domestic Talking Machine Corporation, in an interview with The World representative, stated that Domestic talking machines are meeting with a most favorable reception from the trade.

"We are closing dealers' contracts daily," said Mr. Sheble, "under our sales plan of granting a dealer exclusive selling rights in the territory he can logically cover, and are receiving enthusiastic letters from many of our dealers regarding the favorable reception the public is extending Domestic talking machines.

"Our problems in getting started have certainly been legion, but our plant is now fully equipped, everything is in full swing and our output is increasing by leaps and bounds. Even though this is the dull season of the year we are shipping our product on orders as fast as it comes through.

"Every talking machine manufacturer has faced a serious condition during the past year in endeavoring to secure raw materials, and this situation is not improving materially as far as we can see.

"Several months ago through fortuitous circumstances plus an efficient purchasing organization, we were able to obtain delivery; not promises, of such raw materials as will enable us to operate our plant for some six or eight months to come, and such conditions place us in position to make prompt shipments and insure our being able to take proper care of our trade this fall when the real demand for talking machines starts.

"We thoroughly realize how discouraging it is to a dealer who spends his money creating a demand for a product and then finds deliveries do not materialize. From the present condition

of the raw material market we believe many dealers will face this situation in the fall unless they thoroughly satisfy themselves that delivery promises are based on facts and not on manufacturers' hopes that conditions in the raw material market will better themselves.

"We have had several offers to sell raw materials at advances over cost, but our business is manufacturing talking machines, not speculating in raw materials, and we expect to devote every pound to manufacturing our prod-

uct, as our aim and ambition is to give our trade the prompt service which we feel is such a substantial portion of their opportunity to succeed."

### THE RECOVERY OF SMALL DEBTS

Canadian Legislature Passes Bill Enabling the Collection of Debts of \$50 or Less

WINNIPEG, MAN., CAN., July 31.—A bill of interest to Canadian piano merchants will go into effect the first of August, providing for the recovery of small debts, not exceeding \$50. The bill provides that a creditor may go to the magistrate of a civil court and secure a summons against any debtor who owes said creditor \$50 or less, and upon service of the summons, the debtor shall appear in court and answer the allegation upon which the summons was issued. If the claim of the creditor is proven, the court will then enter judgment against the debtor for the sum in question. The costs of the proceeding are very light, and it is thought that this bill will have a very beneficial effect in enabling merchants to collect small bills which are due them and which hitherto have not been worth the rather high cost of a court proceeding.

### PITTSBURGH DEALERS HOLD OUTING

The Talking Machine Dealers' Association of Pittsburgh held its second annual outing at Olympia Park, near McKeesport late last month. A large number of dealers and their friends attended, and an elaborate program of games and athletic events was given for their entertainment. Prizes were given the winners of the athletic contests, and a bountiful supply of good things for the inner man helped everyone to enjoy the affair.

### A VISITOR FROM MILWAUKEE

Henry M. Steussy, secretary and treasurer of the E. O. Schmidt Piano Co., Milwaukee, Wis., was a caller this week at the offices of the Pathé Frères Phonograph Co., whose products his company handles. Mr. Steussy spoke encouragingly of the business situation in Milwaukee, stating that Pathé business the past two months had been far in advance of expectations.

### CONCEITED

"Van Hamm, the actor, seems to be growing a trifle deaf. I wonder what caused it."

"I'm sure I don't know, but he claims it is the result of constant applause."

PRACTICALLY 100% PROFIT  
on Every Sale of the

*Playerphone*  
The QUALITY TALKING MACHINE

MUSIC  
STORES  
Can Make from  
\$1000 to \$5000  
Extra Profits  
Yearly.

Selling This Beautiful Talking Machine.

It sells on sight and sound—No experience needed to sell Playerphones

Everywhere high-class music stores are handling Playerphones in conjunction with their regular business. People are demanding high-grade cabinet talking machines. There are no finer instruments built than Playerphones, and the Playerphone has the added advantage of playing all disc records as well or better than the instruments for which the records were made. The adjustment of the sapphire ball, Jewel point, steel or fiber needle, as the case may be, and just a slight turn of the wonderfully balanced full curve tone arm does it.

Exclusive Features—100% Profit

These and many other exclusive features make the Playerphone the most popular talking machine on the market and the easiest to sell. Our terms are so liberal that you make about 100 per cent. profit on every sale, and our time payment plan to you permits you to get your profit without having to tie up any money or incur any risk. From the way most music stores are selling Playerphones, you should make

from \$1,000 to \$5,000 extra profit a year, handling the Playerphone.

The Price is Irresistible

That is another wonderful feature of Playerphones. While they are the utmost in talking machine construction, very highly finished in mahogany or oak, the prices of the seven sizes range from \$50 to only \$225. Each one of these Playerphones compares with, and in most cases is, mechanically, musically and artistically, better than instruments selling at from \$75 to \$400.

The complete line of Playerphones is superior in every way. They give you an opportunity for big profit and prestige you can't afford to miss. Come to Chicago and let us demonstrate the Playerphone to you. If you decide to handle our line, your traveling expenses will be refunded. If you can't come, fill out this coupon and mail it to-day—sure!

THE PLAYERPHONE TALKING MACHINE CO.  
General Office and Show Rooms: Republic Building, Chicago, Ill.



Playerphone No. 160

Heavy, five-ply, beautifully finished, mahogany or oak, price \$160. Size 22½ inches wide, 24 inches deep and 50½ inches high. Extra large spring motor and tone arm that plays all makes of disc records perfectly—equipped with Playerphone record albums. We compare this instrument as to tone and quality with others retailing at \$200. Tone arm, crank, and all metal parts gold plated.

#### COUPON

Playerphone Talking Machine Co.  
802 Republic Bldg. Chicago, Ill.  
Gentlemen: We are interested in your Playerphones and would like full particulars and prices submitted to us at once  
Name .....  
Address ..... R.D.

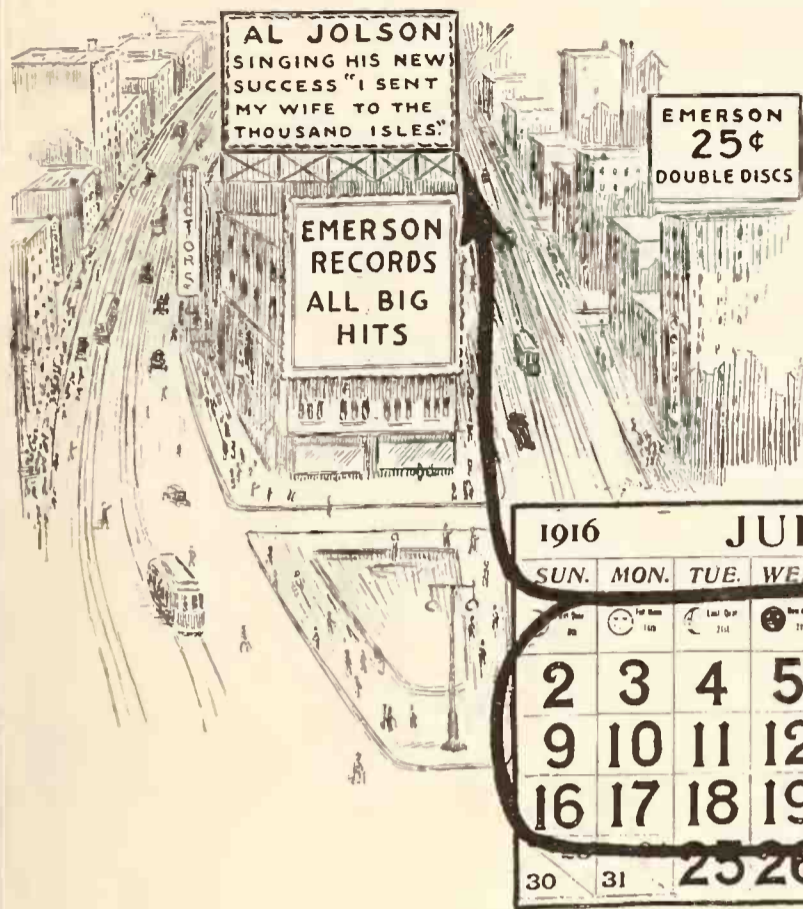

# 3 Weeks From Broadway To Your Store.

1916		JULY						1916	
SUN.	MON.	TUE.	WED.	THU.	FRI.	SAT.			
						1			
2	3	4	5	6	7	8			
9	10	11	12	13	14	15			
16	17	18	19	20	21	22			
30	31	25	26	27	28	29			



Three weeks after Al Jolson first sang, "I Sent My Wife To The Thousand Isles"—an Emerson Record of the song was on the shelves of our dealers.

This is an excellent example of the efficiency and promptness of Emerson recording. While other manufacturers take *months* to release a new number—we take *weeks*. Broadway's stamp of approval is our cue to act. Immediate service is one of the many exclusive Emerson features.

## Emerson 25c Double Discs

have already taken their place in the record field.

Emerson Records are the result of combining the best talent, the most approved methods, and the leading popular selections while they are at the height and even before they are at the height of public favor.

In addition to all this, there is the exclusive Universal playing feature which makes it possible to play Emerson Records on *all* phonographs without an attachment, except one positive feed machine.

Emerson 25c Double Discs play  $\frac{3}{4}$  the time of a standard 10-inch record.

You are losing valuable sales and big profits every day you are without the Emerson line.

A small investment is all that's necessary—the sales are big, the profits liberal, the turnover rapid.

*The first step to big profits is to attach that coupon to your letterhead and mail it to us—take that step now—*

**Emerson Phonograph Co., Inc.**  
 Dept. D, 3 West 35th Street                      New York

**EMERSON PHONOGRAPH CO. Inc.,**  
 DEPT. D, 3 WEST 35th ST.                      NEW YORK

Gentlemen:

Kindly send me at once full particulars about Emerson Records and complete list of your latest hits

Name \_\_\_\_\_

City \_\_\_\_\_

State \_\_\_\_\_

### CONCERT HALL A FEATURE

Of the Attractive and Spacious Store of the Kesselman-O'Driscoll Co. in Milwaukee

MILWAUKEE, WIS., August 4.—One of the attractive Victrola stores in this city is that of the Kesselman-O'Driscoll Co., at 1920 Fond du



Concert Hall at Kesselman-O'Driscoll Store

Lac avenue. The salesrooms are spacious and admirably laid out, while a feature of the establishment, which is proving a great attraction, is the concert hall, which embraces over 400 square feet of floor space. This hall has been placed at the disposal of clubs, societies and individuals for entertainments as a meeting place, free of charge, and has proven quite a business move. Music on the Victrola is supplied to the users of the hall, so that a goodly number of new prospects are made acquainted with the possibilities of the Victor through this means.

### MAKING DISC RECORD CABINETS

The Nanes Art Furniture Co., New York, is now devoting a considerable portion of its plant to the production of disc record cabinets. These cabinets have been on the market for some little time, and have won general praise from the company's dealers. One of the most successful cabinets in the line is the "Esco" wagon, which enables the owner of a machine to wheel the instrument around at his convenience.

The W. B. Smith Music Store, Marietta, O., has been moved to new quarters at 276 Front street, that city.

The Cut Rate Phonograph Shop has leased a new store at 22 East 125th street, New York City.

### BUY YOUR SAPPHIRE NEEDLES

WHILE PRICES ARE LOW

Prices are advancing rapidly on jewel points, so stock up today. We have a tremendous stock of needles at low prices, and can guarantee immediate delivery.

Supertone supplies are made right and are the ideal needles for securing good music.

Don't delay but write today for prices

Supertone Talking Machine Co.  
8 West 20th Street NEW YORK

AND<sup>S</sup> KOCH  
Manufacturer

KOCH-O-PHONE

Phonographs, Parts, Tone Arms, Sound Boxes,  
Records, etc.

Write for samples and prices

296 Broadway, New York

### A GREAT PUBLICATION

Tell the average person that it takes 125 pages, 11 by 15 inches, to thoroughly report the affairs in the talking machine industry of America for a single month, and that individual will think you are a fit subject for an investigation of your sanity. The proof of the matter will be found in the current issue of The Talking Machine World, just issued from the New York offices. This magazine, while of interest to every person having an interest in the talking machine industry, is particularly appealing to the talking machine dealer. The issue just off the press carries the complete report of the recent convention of the National Talking Machine Jobbers held in Atlantic City. The convention is reported in a splendid manner by expert writers. Aside from the convention report there is more than a hundred pages of interesting reading and advertising matter appealing

directly to the dealer. Altogether, it is a great publication and is better than anything yet issued by The World in its history of twelve years' publication. But we wonder how it is possible to issue such a splendid magazine at the very small price of a dollar a year. It certainly is worth more.—R. E. Cord, in the Camden (N. J.) Courier.

### AUGMENT THEIR RECORDING STAFF

"We have been more than pleased with the reception accorded our records by the dealers throughout the country," said T. H. McClure, general manager of the Domino Phonograph Co., New York, in a chat with The World. "In the Middle West, for example, Domino records have not only met with a ready sale, but the dealers have voluntarily written us letters of praise regarding the musical qualities of our product.

"During the past few months we have completed arrangements with a number of well-known artists whose records will be announced in time for our dealers to feature them in our fall trade. We also have other plans which will augment our recording staff materially.

## Jewel Needles

DIAMOND, SAPPHIRE, AGATE

For All Types of Records

Our methods of grinding needles are the most scientific known, producing a most uniform and highly polished product.

We manufacture ALL parts of Talking Machines

Dixon Manufacturing Co., Inc.  
295 FIFTH AVENUE NEW YORK

"Among our records which have been very successful are the recordings by Richard Darville, baritone, and Alan Turner, baritone, both of whom are well known in musical circles, and whose Domino records are gaining in popularity day by day."

A talking machine which announces the hours is the latest invention of a music lover. A series of records is so arranged that a short air is played every fifteen minutes, a longer record marking the full hour. It should make getting up pleasant.

## SINGLE SPRING Straight-gear MOTORS

play 2-10" or 1-12"  
record in one winding

\$1.50 each  
in quantities

This includes all trim-  
mings together with  
10" turn table.

Prompt Delivery

Send \$2.00 for sample

ARROW CO. 207 Market St.  
MOTOR CO. Newark, N. J.

## Talking Machine Supplies and Repair Parts

SPECIALTIES: MAIN SPRINGS, GOVERNOR  
SPRINGS AND SOUND BOX PARTS

THE RENÉ MANUFACTURING CO.

HILLSDALE, NEW JERSEY

Try the

Wizard

SEMI-PERMANENT

NEEDLE

Eliminates the Scratch. Produces a Soft Mellow Tone, bringing out all the richness of either Vocal or Instrumental Music. Will not injure the Finest Record. Write for prices and full particulars.

Send for  
Free  
Sample

H. S. TOWNSEND

1833 VENANGO STREET

PHILADELPHIA, PA.

Patent applied for



## GRAFONOLA PROMINENT AT EDUCATORS' CONVENTION

Work of Educational Department of Columbia Graphophone Co. Wins Praise of Teachers—Furnishes Music for Folk Dancing at City College Stadium

The Columbia Graphophone Co.'s educational division, which is under the direction of Frederic Goodwin, played a prominent part in the activi-

in the musical section exhibit, and the efficiency of the Columbia school product was emphasized by the enthusiastic approval of the visiting



Folk Dancing to Music of the Grafonola

ties of the National Education Association, which convened in New York last month.

Among the events in which the Columbia Grafonola was used was at the stadium of the College of the City of New York, when 4,000 children danced to the music of the Grafonola. The Columbia Co. carried an extensive display

school superintendents and teachers, some 32,000 in number.

Mr. Goodwin suggests that Columbia dealers throughout the country reap the benefit of the pleasing impression created by the Columbia exhibit, and keep in close touch with the teachers and educational authorities in their localities.

## THE VALUE OF PROPER SERVICE IN BUSINESS BUILDING

It Is Through Service That the Manufacturer and Wholesaler Develop and Hold Close Relations with the Dealer—One Instance Where a Jobber's Courtesy Didn't Pay

A good classification, perhaps, of the selling factors that keep the manufacturer and dealer in close harmony, are: 1, quality of products in relation to price; 2, personality of salesmen representing manufacturer; 3, the service offered by the manufacturer to the dealer.

Without harping on the first two, let us consider the matter of co-operative service—a truly twentieth century departure. Manufacturer's service to the dealer may take almost any number of forms—it is limited only by the originality of the men in the manufacturer's employ. Among the more common forms might be mentioned such as help in the matter of copy for retail advertising; circular literature for mailing to prospects, decorative signs and placards, assistance as to efficiency in account keeping, and filling of orders on time, before time, and of a special nature—all of which costs the manufacturer a good deal in point of time and money.

When a dealer is confronted with the prob-

lem of what line to handle, his technical knowledge is brought into play in judging the quality of the manufacturer's product. Naturally this is primarily important. Next comes the personal equation which is not a matter where specific intelligence is called into play—we are influenced by another's personality not so much in accordance with our will to be so influenced as we are in spite of ourselves. There is then just one field, other than the one involving technical knowledge, which requires the exertion of critical judgment. This is the matter of service which the manufacturer offers the dealer.

It behooves the retailer to pay considerable attention to the quality and extent of service and to by all means give due credit to the manufacturer or jobber who is really co-operative in the service proffered. Too often dealers regard service as a legitimate "gift" which entitles the manufacturer or wholesaler to no reciprocation by way of repeat orders and regu-

lar business. The following incident from this year's trade may help illustrate this attitude of the dealer.

A certain retailer wanted a talking machine of a special weathered oak finish. He went to the jobber from whom he usually purchased and was informed it would be impossible to supply such a machine. The dealer then went to another jobber with whom he did some business and was likewise turned down. Finally, he approached a wholesaler with whom he did practically no business and who therefore owed this dealer nothing. Nevertheless, this last wholesaler, in a spirit of real service, offered to try, and as a result, delivered the machine two days before the specified time. Moreover, the wholesaler had to pay dealer's price for the particular machine and in addition assumed the transportation charges which covered some 700 miles.

Now, ordinarily, one would suppose that such generous treatment would warrant gratitude of a decent sort; yet when this wholesaler at a later date phoned the same dealer to ascertain if the dealer wanted some rare records the jobber happened to have in stock, there was lack of even courtesy. The dealer answered the 'phone in person, heard what the jobber had to say, and rejoined, "Wait a minute." The jobber waited for the dealer to determine whether he needed the specific records. To his surprise the 'phone was taken up by the office girl, who, after hearing the story all over again, informed the jobber that Mr. —, the dealer, was busy. Needless to say the jobber hung up his receiver and whistled (or cursed) softly.

The dealer in question not only showed ungentlemanly action and a lack of gratitude for favors conferred at the jobber's expense, but he showed a failure to be thoroughly up-to-date in his business methods. In this stage of commercial life, the live retailer should not only recognize and appreciate service extended by the manufacturer and wholesaler—he should even seek out the wholesaler and manufacturer who offer a good product combined with the greatest amount of practical co-operative service, as the best party to do business with.

### NEW AL JOLSON WINDOW CARD

A new Al Jolson window card in colors has just been issued by the Columbia Co. Al Jolson is termed by many the "King of fun-makers," and his records have achieved signal success. This new window card will doubtless serve to stimulate interest in his Columbia recordings, and thereby influence sales.

### H. C. FOWLER IN NEW POSITION

H. C. Fowler, formerly manager of the Columbia Grafonola department of the Hall-Stephenson Co., of Knoxville, Tenn., is now associated with Sterchi & Haun, in the same capacity, the latter firm having secured the agency for the Columbia line from the Hall-Stephenson Co.

## Two New Triton Winners

—ANNOUNCING the only single spring, worm drive motor of American manufacture. A substantially built motor of standard quality, playing with absolute accuracy of universal speed from beginning to end of a record. Ready for delivery. Sample sent on receipt of \$2.75, complete with ten inch turn table.

Tone arm and reproducer No. 4. Reproducing tone of unexcelled clearness and brilliancy. The arm is of handsome, unusually dignified lines, highly nickel-plated, performing everything that may be expected of a tone arm. Ready for delivery. Complete sample sent on receipt of \$2.00.

Other motors of our manufacture: Single spring gear motor, complete with ten inch turn table, \$1.65; double spring, worm drive motor, playing two twelve inch records with one winding, motor without equal, complete with twelve inch turn table, accurate speed tabulator, \$4.25.

We also make tone arms and sound boxes ranging in prices from \$1.00 to \$3.75 per set.

Triton Phonograph Co., 41 Union Sq., New York

# THE SURVIVAL

A VERY large number of new talking-machines has been placed on market within the last year. Some are good—others VERY POOR. Thousands of dollars have been spent in advertising some of the worst. But assuming that they are all pretty fair—which they are not—how many months of HARD TIMES could one-tenth of the talking-machine manufacturers (95% of them only assemblers) survive? Are you PERMANENTLY ESTABLISHING YOURSELF IN BUSINESS when you sell a Tomtrola, Diapasonola or Harrygraph if you face the very GRAVE probability of Tom, Diapason and Harry SHUTTING UP SHOP?

Have you ever seen the long list of DEFUNCT automobile manufacturers?

## Such an Insurance Policy and Guarantee

handling the new line of talking-machines manufactured by the Flemish-Lynn Phonograph Company. LARGEST, FINEST, NEWEST, MOST EFFICIENTLY EQUIPPED FACTORY IN THE WORLD and the Company's policy of LARGE SALES and SMALL PROFITS accounts for the STARRING PERFECT RECREATORS OF SOUND. THESE PRICES AND SPECIFICATIONS

Model Number	Approximate Measurements	Turn Table	No. of Records at One Winding	Speed Regulator	Retail Price
No. 5	12"x12"x5"	8"	One 12"	Side	
Sturdy, Guaranteed Flemish mute motor. Wonderful tone. Without doubt the biggest value (at its Low Dealer's Price) ever manufactured. Will capture the country .....					
No. 8	14"x15 1/4"x6 3/4"	10"	One 12"	Side	\$ 5.00
Same motor as Model No. 5. Extra heavy tone arm. Three needle cups and other refinements. Self-Starter.....					
No. 10	16"x16"x7"	10"	Three 10"	Top Dial	7.00
Finest, modern, Flemish worm gear, mute motor. Three needle cups, Self-Starter. Beautifully designed and finished. Nothing like it at the price.....					
No. 20.	Size 16"x16"x40 1/2"	10"	Plays 3 1/2"-10" records.	10" turn table. Self-Starter. Top Dial R	10.00

### Everything in or on these Machines

Every model plays all makes of Records—Lateral or Hill and without any attachment. Each machine is equipped with the Absolute New and Unique Wagner Reproducer. This is a tremendously vital It is an Exclusive Feature. It is the Only reproducer playing all records that brings THE NEEDLE POINT TO A PERFECT CENTER. It also inates all vibration. It is foolproof. Turn the screw and the slotted g ADJUST position.

Every model is Mahogany finish. (Richer and more exquisite

### Distributors and Dealers Are Offered Most Unusual Propositions

Reputable, aggressive business-men should make Immediate arrangements to see the Complete Line. Seeing and hearing are believing — Early deliveries on all models

# THE FLEMISH-LYNN

Factories and Test Laboratories, 37th St., Brooklyn, N. Y.

# THE FITTEST

Don't put yourself in the same position as the dealers who have handled their cars! How about your big stock of machines, your rent and other expenses? Are your "contracts" or franchises worth anything? What do *any* companies guarantee you in the way of prices, territory or meeting of competition?

If you wish to consider your money in stock, fixtures, rent and general expenses an INVESTMENT—not a gamble depending on the continuance of boom times, maintenance of inflated prices or the whim of somebody or other—you MUST CONNECT with a manufacturing company that INSURES and GUARANTEES that your money is SAFELY, PERMANENTLY, CO-OPERATIVELY INVESTED.

## Offered All Distributors and Dealers

Tens of thousands of dollars have been invested by the men whose genius has made possible the manufacture of any similar line of talking-machines. Its TREMENDOUS CAPACITY AT LOW PRICES of a line of UNPRECEDENTEDLY EXQUISITE, SCIENTIFICALLY PERFECTED MACHINES THEMSELVES!

Model Number	Approximate Measurements	Turn Table	No. of Records at One Winding	Speed Regulator	Retail Price
15	13½"x17"x12¼"	10"	Three 10"	Top Dial	\$15
Exquisitely designed Crown Moulded Top Cover. Same wonderful Extra values as Model No. 10.					
35	16½"x19"x40"	12"	4½"-10"	Top Dial	35
Neatest, modern, Flemish Double-Spring Mute Motor. Flemish Pivot Tone Arm. Double-door, handsome cabinet with 4 record shelves. The equal of any \$75 machine.					
50	18"x22¾"x41"	12"	Five 10"	Top Dial	50
Even larger, finer, and more extravagantly equipped and finished than Model No. 35. Super-Mute Motor. More spacious cabinet, with 5 record shelves—the Ne Plus Ultra of Talking Machines.					
Designed Cabinet, holding 35 individual records. Artistic Top Cover. The Supreme Value.					20

## Manufactured in our own factories

(models.) But in the more modest models we do not charge extra for any finish.

Every model (except No. 5) is equipped with the most modern SELF-STARTER—a real innovation on machines for Everyman. This automatic starting device banishes unsightly brakes.

Every model (except No. 5) has three or more NEEDLE CUPS.

All models have all-wood cabinets. All-wood (specially selected and finished) sound chambers. Scientifically correct sound boxes and tone arms. Exquisitely finished.

Size, beauty and refinements and conveniences extraordinary are essential to any fine line of talking machines.

Correct prices are a vital necessity, but

The all important consideration is

# TONE

# NOGRAPH COMPANY

Sales Offices, N. E. cor. 41st St. and Madison Ave., New York City

# Cavanaugh Cabinets

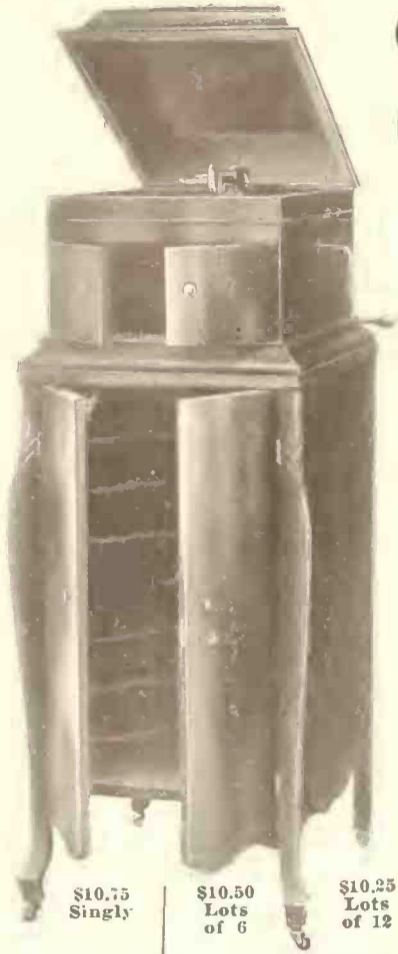

\$10.75  
Singly

\$10.50  
Lots  
of 6

\$10.25  
Lots  
of 12

*Built from the standpoint of the customer. The special Cavanaugh-run makes the machine and cabinet look like a unit, instead of two separate pieces.*

**Original In Design—Superior In Workmanship—In All Victor Finishes**

*Cavanaugh's Cabinets have increased the Victor business wherever they have been put on sale. Yours is no exception.*

**J. J. CAVANAUGH**

452 Fulton Street :: Brooklyn, N. Y.

Catalogue on request



\$10.25  
Singly

\$10.00  
Lots  
of 6

\$9.75  
Lots  
of 12

## QUALITY BASIS OF COMPETITION

Not Price Juggling or Shell-Game Methods—  
Some Interesting Observations

The world is surely, if somewhat slowly, coming to realize that quality is the real basis of competition. What's the use of buying a piano or a suit of clothes for a small sum of money if they are of such inferior quality that they cannot satisfactorily serve the purpose for which they were designed?

Advertising and the use of trade marks have brought about a tremendous improvement in business conditions which is of direct benefit to the public. The Ingersoll dollar watch has become a standard by which all watches can be measured. The public has found out what a dollar should be able to buy.

If the man who thinks 98 cents is enough to pay for an Ingersoll watch will open up an exclusive store to handle nothing but Ingersoll watches, he will find out that he has been mistaken. Or, again, if he thinks the dealer pays too much for the watches he buys from the factory, let him build a watch which can be sold for less and do the same work. He will find out

again that he has been considerably mistaken.

It doesn't take brains to substitute cheap material—all you need is a yellow streak and no conscience.

Good material is good material, and its value is established. There are boundaries beyond which not even the largest corporation can go. We, for instance, use immense quantities of mahogany. Mahogany represents value. We can buy it in the open market for about so much and then we come to the limit. Even if we went to Africa and acquired certain lands on which mahogany grows, we should have to cut and ship that mahogany to the point where it can be manufactured. Having done that we should find that our own mahogany was costing as much—or more—as the mahogany we had bought on the open market.

The same thing is true in every line of manufacture, and so long as first-class material has a certain value, no one can cut prices without making it up somewhere else. That is merely robbing Peter to pay Paul.

There was a time when the wealthy manufacturer could pull off all sorts of underhand stunts and put unfriendly dealers or competing

manufacturers out of business by juggling with the price and varying the quality to suit, says the "Voice of the Victor." But once a manufacturer puts a trade mark on his goods and advertises the price of them, he has given hostages to fortune—he—while he may not have intended to do so—has given a bond guaranteeing his own good behavior.

Competition, far from being eliminated, becomes even more active and of more value to the public. The Ingersoll dollar watch will continue to prosper—as it should—so long as it continues to be an eminently satisfactory dollar's worth. Any other manufacturer who can produce a better watch at a dollar is entirely free to do so, and such competition—a competition in quality—is of real and measurable benefit to the public, while price cutting or price juggling represents nothing more than a glorified shell game.

R. F. Bolton, district manager of the Columbia Graphophone Co., New York division, returned recently from a fortnight's stay at Asbury Park, N. J. In his absence his sales staff hung up record breaking figures for the month.

## Experts Pronounce It An Unparalleled Success

The tone reproduction of our No. 2 tone-arm and reproducer sketched below, is just what you are looking for.

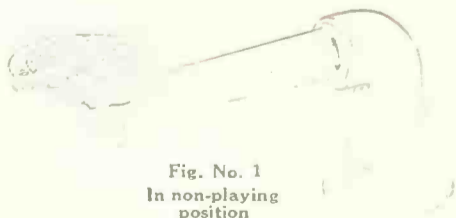

Fig. No. 1  
In non-playing  
position



Fig. No. 2  
Lateral cut  
record position

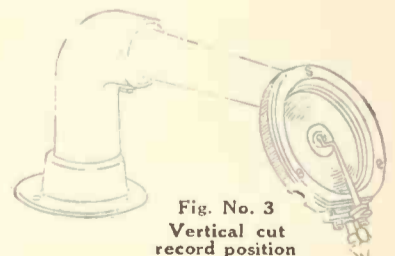

Fig. No. 3  
Vertical cut  
record position

TO CHANGE POSITIONS, FOLLOW THE ARROW POINT

### PREPAREDNESS

We are prepared and ready to ship at once, subject to exhaustion of immense stock, the following motors: No. 0, No. 1, No. 2, No. 3 and No. 4

**INDEPENDENT GERMAN-AMERICAN TALKING MACHINE CO., Inc.**

54-56 BLEECKER STREET, NEW YORK CITY

# REPAIRS

TALKING MACHINE TROUBLES AND HOW TO REMEDY THEM

Conducted by Andrew H. Dodin

[This department of The Talking Machine World which was started with the April issue, is designed for the service of all classes of our readers, including those who make, and those who sell, talking machines. A talking machine out of order often reflects both upon the maker and dealer, and yet frequently the trouble is so slight that the simple knowledge of repairs will permit of the machine being put into proper running order, quickly and practically without expense. In the large cities talking machine repair shops are, of course, available, but this department should prove of particular value to the out-of-town talking machine men.]

Andrew H. Dodin, who conducts this department, has a wide and enviable reputation as a repairer of talking machines and conducts an exclusive talking machine repair shop at 25 East Fourteenth street, New York. Tell him your troubles through The World and he will help you if possible. The service is free.—Editor.]

## REPAIRS THAT CAN BE MADE WITHOUT THE USE OF NEW PARTS

Many repairmen and dealers have at different times been confronted with the difficulty of securing the proper part to replace a broken or worn one, and particularly has it become the case at the present time when repair shops are beginning to receive in greater numbers the small cheaply made motors—both foreign and

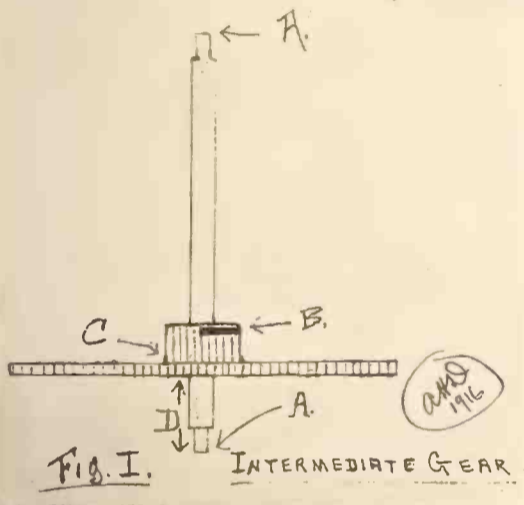

domestic. I want to say a few words to the repairman who must get his repair out without waiting for the new part to arrive and try and show with the aid of a few simple shop drawings, how a broken gear or the broken teeth of a spring cage gear can be easily repaired.

The teeth of the pinion on the intermediate gear in many cases become stripped in one place, Fig. 1, B, permitting spring cage gear to run free. As spring cage gear almost always runs in a position nearly at top of pinion—it is always possible to take pinion gear and turn same around, bringing the bottom, C, Fig. 1,

of teeth or undamaged part into playing position.

To do this I place gear in vise—Fig. 2—strike shaft at A driving same through pinion

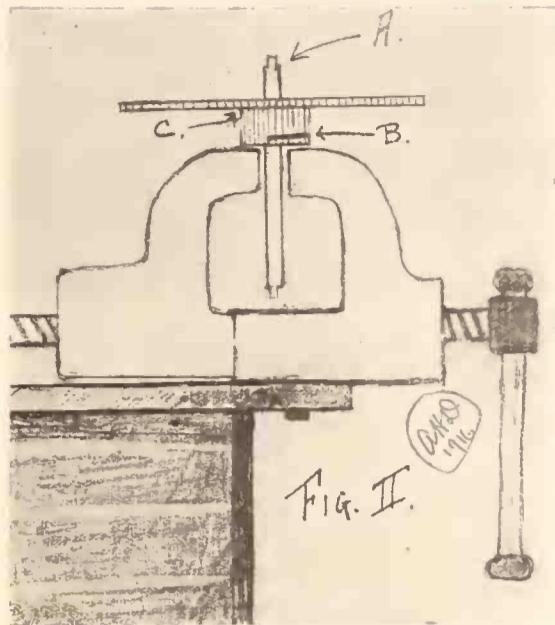

and gear—and in doing so I am very careful not to damage shaft bearing points at A. In some cases pinion is set into gear at C and it will be necessary to take a file and shape opposite end of pinion to fit into the brass gear.

After fitting pinion to gear I replace shaft getting distance from bottom of gear to end of shaft D, Fig. 1, about the same as it was originally, then place gear and spring cage into motor and see how cage gear meshes with pinion. It may be necessary to drive shaft a little further through gear in order to get

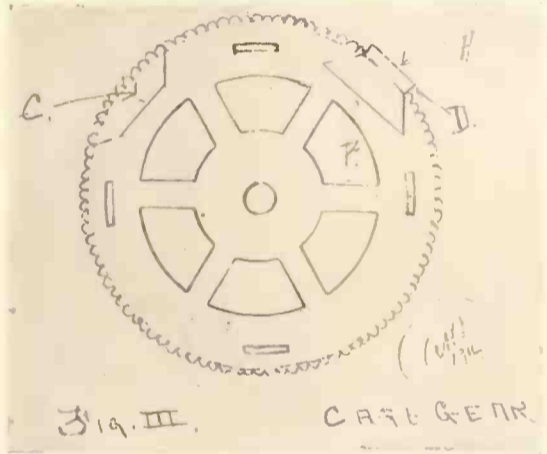

pinion into just the proper running position.

The spring cage gears on these types of motors are also a source of a great deal of trouble. The teeth are very often broken off or mashed in such a way that the gear will

not run in mesh with pinion teeth on intermediate gear.

It is a very easy matter to replace the broken teeth in these gears providing you have facilities for soldering, a good file, a jeweler's saw and some small pieces of brass or steel plate.

In Fig. 3 at A you will see the outline of the piece I cut out of gear where teeth have been broken off, making my saw cuts at an angle so that when new piece is fitted and soldered into place it will be impossible to pull it out. At C you will notice outline of the wrong way to make saw cuts. When a piece of this shape is soldered in it is liable to pull out at any time. After making the cut in gear I take a small piece of material and file it into shape so that it fits loosely into cut—leaving a projecting piece at D big enough to file out the new teeth. Now solder the piece into position—file flush on both sides of plate and then shape the required number of teeth with a small file.

Before replacing gear on spring cage be sure that spring is caught on hook of shaft and that spring has proper graphite mixture. I advise the use of Ilsley's graphite lubricant, which can be purchased ready mixed in just the right proportion of graphite, oil, etc., so that it is unnecessary for you to add anything to it and for these small spring cages would use only about a tablespoonful to the cage, more than that would prevent motor from running a 12-inch record.

## DESCRIPTION OF RECORD THIEF

Local Dealers Describe Negro Who Is Reported to Have Stolen Many Records from Local Stores During Past Few Weeks

At the last meeting of the Talking Machine Men, Inc., several members gave an excellent description of the record thief who has been operating to considerable extent in various parts of the city. According to the descriptions, which agreed, the offender is a prosperous looking light complexioned negro, about five feet seven inches tall, and rather stout, whose method of working is to abstract the records from their accustomed racks and place them in a false pocket in the front of his trousers. They say that the thief is very clever in finding means for causing clerks to go to another part of the store while he grabs the records. He does not appear to favor any particular records, but takes those most conveniently at hand.

The Phonograph Finance Co., of Cleveland, O., was recently granted a charter of incorporation by the Secretary of State at Columbus, O. The concern is capitalized at \$5,000.

# “What’s a Pearsall SERVICEE?” said a dealer

This was a new one to him, although he had been one for a number of years. A PEARSALL SERVICEE is a dealer who is served by Pearsall Victor Service; he is one of those men who know good service, and who is growing because he lets us help him.

Better find out for yourself that this is true.

SILAS E. PEARSALL CO.,

NEW YORK  
AT 18 WEST 46th STREET  
NEAR FIFTH AVENUE



The long wear of Columbia Records is a feature that printed words hardly convey. But in practice there is no mistaking it. It is a feature that is peculiarly Columbia and once a record buyer realizes it, he is solid.

(Write for "Music Money," a book "full of meat" for those dealers interested in quick and frequent turnover of capital.)

Columbia Graphophone Co.  
Woolworth Building, New York

## UNUSUALLY HEAVY RECORD BUSINESS IN MILWAUKEE

Sales Come Close to Exceeding Those During Holiday Season—Influx of Cheap Machines Has Effect—Progress of the Sonora Line—Ministers Praise Aeolian-Vocalion—Edison Dealers in Milwaukee Forming Trade Association—Other News of the Month

MILWAUKEE, Wis., August 8.—Sales of records in Milwaukee during July reached the largest volume ever known in any one month, save only the period preceding the Christmas holidays. The enormous disposition of records actually created a serious shortage at one time during the month, but herculean efforts by the jobbers in getting quick action from the factories overcame the difficulty and at this time the trade is ready for most any kind of a crisis.

The sale of machines is being well maintained, but the recent spell of terrific heat has affected business to some extent, which naturally is to be expected in July and August. Nevertheless, dealers say stocks are moving faster than last year.

The influx of so-called cheap machines, retailing at \$5 to \$15 admittedly, has cut into the sale of higher-priced machines, especially for summer home and outing use. As a matter of fact, however, most of the people who buy a \$5 talker for country use have purchased regular machines for their homes, and every machine sold, whether it cost \$5 or \$500, is a potential record customer, so the odds are about even.

The Premier Talking Machine Co., which established a Milwaukee branch on October 1, 1915, has promoted Manager Park Adams to the position of manager of the new Michigan branch, with headquarters at Detroit. T. W. Abell, of New York, has succeeded Mr. Adams as manager of the Milwaukee interests, at 220 West Water street. This branch handles the wholesale business of Wisconsin and Upper Michigan.

The Sonora phonograph continues to increase its popularity in this territory under the able direction of Charles J. Orth, 276 West Water street. Hot weather has not been a particular drawback to sales, Mr. Orth says, and inasmuch as the manufacturers now are able to make deliveries on schedule time, his July volume of sales was the largest since he took this line. As a high class piano man, Mr. Orth has established an enviable reputation, which is coming in good stead on phonograph business. Oftentimes a prospective customer calls Mr. Orth by telephone, and upon receiving his assurance as to Sonora quality, the order is placed without even a demonstration. Most of Mr. Orth's Sonora sales are above the \$100 mark, and a very few are below \$75.

The Aeolian-Vocalion was introduced to a distinct class of trade by the Edmund Gram Music House, 414-416 Milwaukee street, a short time ago when Mr. Gram gave a recital before 100 members of the Wisconsin Synodal convention of the Evangelical Lutheran Church. The ministers were loud in their praise of the Vocalion, particularly after the rendition of a selection like "Open the Gates of the Temple,"

by Evan Williams, with accompaniment on the Edmund Gram parlor grand piano by Mr. Gram himself. Paul Seeger, manager of the Aeolian department at Gram's, reports a splendid run of business, especially in the \$100 and \$150 styles. Every Steinway piano customer of the Gram house is being canvassed, and the campaign has resulted in a large number of sales of the costlier styles, with and without electric motor attachment. Mr. Seeger and his family have been enjoying a summer home on the upper Milwaukee River this summer.

Edison retailers in Milwaukee are forming an association for mutual benefit and sociability. Dealers and their employes will be eligible to membership, and one of the objects will be to effect a stronger co-operation between interests representing the same line in the same city. H. N. Hahn, manager of the Edison department at the C. Niss Furniture Co., is temporary chairman, and H. W. Gausewitz, manager of the retail department of the Edison Shop, 213 Second street, is secretary. The dealers include the George H. Eichholz Co., 542 Twelfth street; Edison Shop, Art B. Meyers, 460 Eleventh avenue, Miss Co., 709 Third street, and the Flanner-Hafsoos Music House, 417 Broadway.

Glynn and Sylvester Cremer, Cashton, Wis.,

have opened a music and jewelry store in the Granville Hall building and advertise both the Edison and Victor lines.

The remodeled Victrola department of the Milwaukee Boston Store is nearly ready for the grand opening planned by Manager James Schoonmaker during the week of August 14. Business has been conducted in spite of the handicap of remodeling work and torrid weather. The department is equipped with eight new large type booths, electrically lighted and ventilated. A large record room and a concert hall also have been provided.

Leslie C. Parker, manager of the Victrola department at Gimbel's, attended the recent World's Salesmanship Congress at Detroit, and upon his return to Milwaukee took the initiative in a movement to organize a Milwaukee Salesmanship Club. He has been given the co-operation of the Merchants and Manufacturers' Association, Advertisers' Club and other organizations. Mr. Parker is one of the leading sales managers of Milwaukee.

A. G. Kunde, Columbia jobbers, 516 Grand avenue, have had the busiest month in their experience. Mr. Kunde has been participating in numerous short excursions with the jobbers' division of the Merchants and Manufacturers' Association, and was a member of the week's handshaking tour, conducted by the Tripoli Temple, Mystic Shrine. The Columbia thus was the "official" talking machine on four special trains in less than two months. On July 31, Mr. Kunde made the jobbers' excursion to Delavan, and on the following Thursday night



## Truetone Combination Sets

MADE IN U. S. A.

Five different tones, each tone packed separately. 200 in a metal box, 5 boxes in a convenient container holding 1000 needles, retailing at 75c.

Five of these containers packed in a carton and sent prepaid to dealers anywhere in U. S. for \$1.50, and postage on 2½ lbs.

(Cash with order on sample lots)

NEW YORK DISC NEEDLE CO.

110 WORTH STREET, NEW YORK CITY

**Truetone**  
TRADE MARK

Highest Grade  
Ever Made

SEND FOR SAMPLES AND PRICES ON OUR COMPLETE LINE

accompanied the annual across-the-lake jobbers' excursion to Mainstee, Mich. The house of Kunde received valuable publicity by its donation of three Columbia machines and a supply of records to the Milwaukee companies of the Wisconsin National Guard forming the First Wisconsin Brigade now encamped near San Antonio, Tex. Letters from the soldier boys thanking Mr. and Mrs. Kunde for their much appreciated gift are still coming.

Harry A. Goldsmith, secretary of the Badger Talking Machine Co., 135 Second street, recently was elected a member of the Milwaukee Press Club. Mr. Goldsmith is a former newspaper man, and an expert writer on financial topics, but forsook the pen to job the Victor in Wisconsin and Upper Michigan two years ago.

J. H. Becker, manager of the Victrola department of the Twelfth street store, and O. Meyer, manager of the same division of the Mitchell street store of Edward Schuster & Co., Milwaukee, have been spending their annual vacations at their favorite lakes in Waukesha county. Mr. Becker spent his time at Nagawicka Lake, and Mr. Meyer, as usual, went to Oconomowoc Lake. During their absences, the work of remodeling the Victrola departments was carried on with extra vigor and rushed to completion. T. P. Lehrner, general manager of the piano and talking machine interests of the three Schuster stores, is now on his vacation.

August C. Quentmeyer, Premier dealer at Columbus, Wis., showed his public spirit by donating a Premier to the Columbus Municipal Park Commission to assist in raising funds required for building an ornamental entrance and otherwise improving the city park.

D. F. Roate, Algoma, Wis., has sold his stock of musical merchandise and will retire.

John Feuerstein is a new piano and talking machine dealer at Sturgeon Bay, Wis. He will handle the Victor exclusively.

The business of the Milwaukee Talking Machine Manufacturing Co., 416-418 Fourth street, has been incorporated with an authorized capital of \$75,000. Edward Heaney is president and Frank A. Welsand, secretary. The incorporation indicates no change in the business or policies of the company.

A. J. Boden, Victor dealer at Clintonville, Wis., drove to Milwaukee in his new car to call on the Badger Talking Machine Co. Mr. Boden placed a large order for fall delivery.

The Pathophone was exhibited by the Pathophone Co., of Wisconsin, 183 Fourth street, at the recent annual convention of the Wisconsin Retail Jewelers' Association. Manager Lawrence McGreal was in charge of the exhibit and gained a number of fine dealers among the jewelers. The Pathé was the only talker represented at the convention.

"There is only one trouble," says the reporter of a Berlin, Wis., newspaper, "with the new arrangement at Neumann & Hoyer's drug store and ice cream parlor since Mr. Doering sold them one of the \$250 Edison phonographs. There is such a variety of excellent music coming from the instrument, and so many good things to eat while getting the good music, that one is liable to forget that there is work to be done."

The Hatten Lumber Co., New London, Wis., one of the oldest and largest logging and lumbering companies in Wisconsin, has installed a complete Dictaphone system in its big offices.

G. F. Rueb, president of the Badger Talking Machine Co., 135 Second street, has returned from a two weeks' automobile trip through northern Wisconsin and upper Michigan with his family.

The Starr phonograph is enjoying a fine run of business in Milwaukee and throughout Wisconsin since the Hoeffler Manufacturing Co. took on the wholesale contract for this territory.

"Jimmie" Cox, former champion speedway motorcyclist of the country, and later a member of the retail force of the Badger Talking Machine Shop, is one of the Milwaukee music

trades men now on the Mexican border with the Wisconsin troops. Mr. Cox has been detailed to the motorcycle squad.

Several large chair and furniture factories in Wisconsin have recently made advantageous contracts for the manufacture of cabinets for talking machine manufacturers, and much capacity is being turned over to the new work. One of the largest producers at this time is the Wisconsin Seating Co., New London, Wis., which has contracted with the Edison interests for a large part of its cabinet requirements. The Wisconsin Chair Co., Port Washington, Wis., is also building an enormous lot of phonograph cabinets on contracts.

"We have experienced a summer resort business both on machines and records that is simply wonderful," was the report of R. H. Zinke, manager of the Badger Talking Machine Shop. Mr. Zinke said there was still cause for complaint on the shortage of machines, but records are coming more freely. Outside of summer resort business, trade is seasonable, but better than in any past year. The

black and white outing room told of in the last issue of The World has made such a decided hit with the Badger's trade that Mr. Zinke is now working out a Hawaiian room, furnished with real Hawaiian materials direct from the islands.

### DOMESTIC CO. ON PACIFIC COAST

Walter S. Gray, Pacific Coast manager of the Domestic Talking Machine Co., Philadelphia, Pa., has opened headquarters in the Chronicle Building, San Francisco.

### WILL NOT WHOLESALE TALKERS

Steinway & Sons, New York, this week officially denied any intention of wholesaling the Clayola talking machine to any Steinway dealers who might desire to handle this machine. Steinway & Sons will handle this machine in their Middle West stores, and any other rumors in connection with their activities in this direction are without foundation.

the Spokane Expert School of Business, has installed a Columbia graphophone in his school other fellow never thought of doing—and didn't do when he was told.

## Are You on the Border?

Not Mexico—but on the border of profits or no profits. To keep away the no-profit enemy, be well armed with machines and records, maintaining a battery of the different Victor styles and several regiments of records.

## Gately-Haire Service Is on a War Footing

It is ready at all times to rush to your assistance with plenty of reinforcements, so you won't waste a single selling shell. No gilt braid or frills but plenty of hard work and a co-operation that has had the experience of war campaigns in many commercial centres.



*Join the G-H colors. Service only as long as you are satisfied.*

**Gately-Haire Company, Inc.**  
JOHN L. GATELY, Pres.

121 N. Pearl Street  
Sumner Bldg.

**ALBANY**

# ALBANY

## "for capital service"

**NEED WE SAY MORE?**

**THE GATELY-HAIRE CO., Inc.**  
JOHN L. GATELY, President

# 13,000,000 People Attend Movies Daily

Are You Reaching This Tremendous Field?



Our animated film service in your territory identifies your store and business with the enormous drawing power of the Victor National Publicity.

This film service is another of our valuable "Helps to Dealers."  
Write for particulars.

**Chicago Talking Machine Company**

*Victor Distributors*

12 No. Michigan Avenue . . . . . Chicago



# FROM OUR CHICAGO HEADQUARTERS

E. P. VAN HARLINGEN, Manager  
HENRY S. KINGWILL, Associate

World Office  
Consumers' Bldg., 220 South State St., Chicago  
Telephone: Wabash 5774

CHICAGO, ILL., August 7.—It's really getting monotonous, this writing reviews of conditions in the talking machine trade. There is so little change from month to month. It's just the same old story—business showing a notable increase over the corresponding month of the preceding year—a continued shortage of goods notwithstanding continually increasing the output of the factories. Record stocks are in excellent condition and demands on them show that the dealers are doing considerable business right in the midst of the heated term. Never in the history of the trade have dealers generally placed their fall orders so early. Although some of the jobbers for the old established companies seemed to be a little perturbed for a while over the influx of the host of new talking machine manufacturers, they are inclined to look at the matter in a very philosophical manner now. Instead of a reduction in business it is steadily increasing at a wonderful rate. It is evident that this is going to continue, although the new concerns will also sell a lot of machines—those that are conscientious regarding their product and who pursue legitimate sales methods. It simply means that the consumer is going to be worked more intensively than ever before because there will be so many more dealers after him, and this educational process will increase vastly the number of purchasers. That's the view being taken by veterans in the distributing field, and it is no doubt the correct one.

#### Displays Dealers Efficiency Devices

Important changes are being made in the extensive quarters of the Chicago Talking Machine Co., at 12 North Michigan avenue with a view to giving visiting dealers practical demonstrations of the various efficiency devices and methods originated by the company with a view to enabling the dealer to systematize and organize his business on the best possible basis. The company's repair department has been housed in a well-lighted enclosure and made a model department in every way, in point of equipment, cabinets for repair parts, accessories, etc. The shipping department has been put on dress parade so to speak, and dealers are invited to inspect it and learn how the systems there employed can be adapted to their own business. Immediately opposite the dem-

onstrating booths in the main warerooms an addition to the efficiency and service department is being established, in the way of a room 12x10 feet in size in which the various forms and systems supplied by the company will be placed before the dealer in actual operation, such as the Tomaco record racks for dealers with the stock envelope signals for automatically keeping track of condition of stock and of good and slow selling records, etc. On a convenient table will be the Tomaco stock book for ordering records, while the monthly window card service and other advertising matter will be appropriately displayed.

#### To Open Woodlawn Pathé Shop

R. E. Rundell, formerly sales manager of the Pathé-Pathephone Co., of Illinois, which was recently withdrawn from business and whose offices were taken over by the phonograph division of the Hallet & Davis Piano Co., will enter the retail business and will open, about September 1, the Woodlawn Pathé Shop at 1314 East Sixty-third street. Mr. Rundell will have associated with him in his new venture H. D. Blodgett, formerly of the State Street Pathephone Shops.

#### Cable-Nelson Catalog Issued

The Cable-Nelson Piano Co., of Chicago, has made its first formal announcement of the "Cable-Nelson talking machine" through the medium of a neat little brochure that gives a concise but very clear and complete description of the machine and the parts that go into it. An illustration of the model factories of the company at South Haven, Mich., is also included in the booklet.

#### Sonora Takes Additional Space

Thomas R. Johnson, in charge of local activities of the Sonora Phonograph Corporation, announces that the company has taken the entire second floor of the building at 320 South Wabash avenue, where the concern is now located on the top floor. The new space will be almost entirely used for wareroom space, although a demonstration room in which to demonstrate the Sonora to dealers may be located there also. The new space amounts to between four and five thousand square feet, and should be a great help to the Chicago distributing center especially with the approach of the busy holiday season. According to Mr.

Johnson the summer season has proved to be anything but dull this year, and says his books show a doubling of business over last year.

#### Completes Important Deals

H. A. Yerkes, division superintendent of the Columbia Graphophone Co., is doing much traveling nowadays, and in the past month has consummated several important deals involving the wholesale distribution of Columbia goods from several pivotal points in the extensive territory under his jurisdiction. He recently made a trip, including Denver, Salt Lake City, Omaha and Lincoln. At Salt Lake City, he arranged for an extension of operations of Dalzell Bros., operating at Denver as jobbers under the name of the Columbia Stores Co. They will open another distributing point at Salt Lake, and have secured commodious exclusive wholesale quarters in the Dooley Block. They will also specialize on the Dictaphone.

On his return from the West Mr. Yerkes went to New Orleans. As a result of his visit the Columbia Co. will withdraw from the retail business in the Crescent City, devoting their energies to the dealers. Exclusive wholesale quarters have been secured in a large building on Canal street, and it will be fitted up in a manner enabling them to care for the wants of dealers in that section in a more efficient manner than ever.

#### Starting Right

Miss Elizabeth M. Shaw, for some years with the Chicago Talking Machine Co., and one of as pulchritudinous a group of young women as can be found out of captivity, surrendered her liberty last month and married Lloyd McLean Thomas, a prominent young business man of Little Rock, Ark. The wedding gifts were many, but none were more prized than a Victrola and records from her former employers. The standard of musical culcha will be rigidly maintained at the C. T. M. Co.

Mr. Creed hopes that Miss Shaw's example will not prove contagious, but the gleam of diamonds from feminine fingers gives rise to serious doubts.

#### New Stores and Departments

The South Shore Talking Machine and Lamp Shop is the name of a new concern that has opened very handsome quarters at 6719 Stony Island avenue. They handle Columbia goods.

(Continued on page 73)

## THE WADE—THE PRACTICAL—THE WADE Fibre Needle Cutter

The WADE embodies the right principle, worked out through long experience. It is simple, durable and accurate. It trims the needle at an angle resulting in the best tone. The WADE cutters are made of the best steel and are absolutely guaranteed.

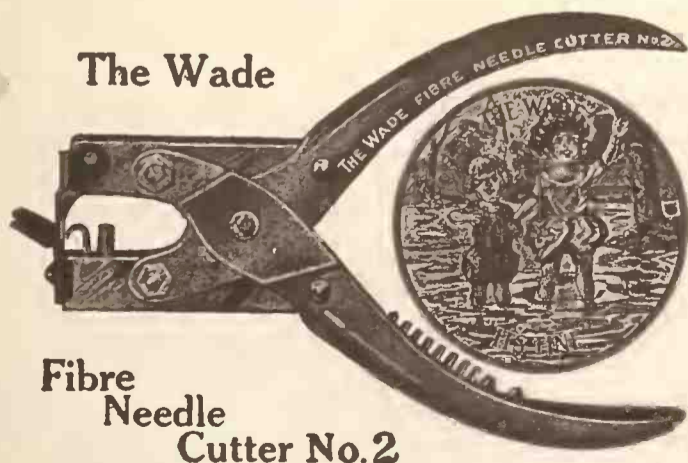

The WADE has a self-acting stop, which prevents waste and enables one to get from 12 to 15 perfect playing points from one fibre needle. No. 2 has a double action, making it especially easy to operate. No. 1 is a very popular cutter which has given excellent service. You save more than double the price of the Wade in the repointing of the first 50c. worth of needles.

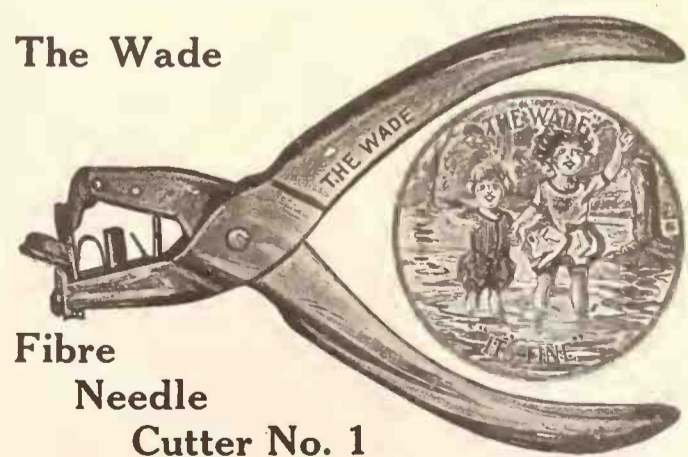

RETAIL PRICES—No. 1, \$1.50; No. 2, \$2.00

Order from your regular Distributor—we sell to Jobbers only

**WADE & WADE,**

3807 Lake Park Ave.  
CHICAGO, ILL.



## Turn that interest into sales!

**D**URING the Summer thousands of people have had their interest aroused in the Victrola, at camp, at the lakes, sea shore, their neighbors' or similar places. Prepare for these people now while they feel the effects of that "Buying Influence." They will greatly increase your volume of business.

An up-to-date stock and a constant supply of the latest releases is what will interest them.

Lyon & Healy have the largest jobbing stock of Victor Records in the country. We have a *Half Million Records* ready for immediate shipment.

Our specialty is SERVICE. We make quick deliveries. Our Victor Stocks are always as complete as possible in every detail, including many quick selling accessories.

Our SERVICE includes sales helps which make a dealer's store distinctive, sales helps which develop business and increase profits.

Enjoy the advantages of buying all of your musical goods from one house; it means one order, one shipment, one transportation charge, and a saving in freight as well.

## LYON & HEALY

World's Foremost Music House

Wabash Ave. and Jackson Blvd.  
CHICAGO



FROM OUR CHICAGO HEADQUARTERS—(Continued from page 71)

Hassmer Bros., piano merchants (905 Belmont avenue), have added a talking machine department, specializing on Columbia goods.

Nielsen & Leshner, 1961 North Halstead street, have added Columbia graphophones.

The Goldberg Furniture Co., who conduct several stores in Chicago, have opened a new one, and their largest, at 3014-20 Lincoln avenue. It has a frontage of 1010 feet and has a well equipped Columbia department as have their other establishments.

The Kennedy Furniture Co. have opened a new store at 3948 West Twelfth street. They will handle the complete Columbia line and are putting up two demonstration booths.

Other dealers who have added the Columbia line exclusively include S. Olkenitzky, music dealer, 8453 Burley avenue, Chicago.

The Central Music Co. is the name of a new concern just opening a music, piano and talking machine store at 5621 West Twenty-second street, Cicero. Richard Navatny and Joseph Chlebeczek are the proprietors. They have arranged for the Columbia line.

#### Tells About English Conditions

Frank Samuel, general manager of Barnett Samuel & Sons, Ltd., of London, made some interesting revelations regarding the effect of the great war on the English music trades in a chat with *The World* this month. Mr. Samuel's presence in America at this time is mainly due to the absolute necessity for a respite from the overwork and mental strain experienced since the outbreak of the war.

The house of Barnett Samuel & Sons, Ltd., was established in 1832 and Frank Samuel is a grandson of the founder. When the war started there were four men by the name of Samuel in charge of the destinies of the old house—two brothers and two cousins. All of them with the exception of Frank Samuel, who was selected to stay in charge of the business and look after government contracts, enlisted. Edgar Samuel, a lieutenant in charge of the bomb corps, was killed in France in January. The other two are still at the front. The company manufacture the Boyd pianos and the Boyd Pistonola player-pianola. The latter created a great deal of interest when it was exhibited in Chicago two or three years ago. The company also make band instruments and drums on a large scale and handle small goods of all descriptions. They publish an enormous catalog, handsomely illustrated, with color process cuts and do a large trade with the colonies. In the last three years they have supplied something like 12,000 drums to the British army and the drum shop is the only portion of the plant which has not been hampered because of enlistments. It has been to the interest of the government, of course, to keep that department working in force. They have also sold a large number of trumpets of the national army design to the British government.

Besides their other musical instrument activities Barnett Samuel & Sons have long been

an important factor in the talking machine manufacturing field. In April of 1913 they brought out the "Decca," an interesting machine which folds up into valise form, much after the fashion of the folding organs known to the American market. This was not a cheap machine as English prices go, ranging from five to ten pounds retail. It was designed originally for the summer resort trade, but when four months later the war broke out the house was quick to see the value of the machine as a means of furnishing musical entertainment and diverting the mental tension of the soldiers in the trenches. A strong advertising campaign was started in the daily papers and in periodicals advising people to send a "Decca" to the boys at the front. So far about 40,000 of these machines have been sold for that purpose. Mr. Samuel says that the talking machine business among the stay-at-homes in England is remarkably good, and that there is a greater proportion of the higher grade goods sold than ever before. The reason for this is dual. In the first place there has been a shutting off of competition of cheap foreign machines and the remarkable salaries paid to both men and women in the munition factories have made them large purchasers of what are usually termed luxuries.

#### Has Fine Summer Home

C. F. Baer, manager of the Chicago office of the Columbia Phonograph Co., gave a little "party" Sunday to a few of his friends in celebration of the completion of his fine new summer home on Lake Kathryn, near Antioch, Ill.



C. F. Baer's Summer Home

It stands on the site of the less pretentious cottage which he has had there for several years, and is one of the most beautiful and best equipped houses on the lake. Mr. Baer can spend Thanksgiving and Christmas there, if he chooses, as it is most substantially built, and besides screened sleeping porches, bathroom and all summering conveniences, has electric lights and hot water heat. In the photograph taken Sunday and here reproduced are seen Mr. and Mrs. Baer and the two little Baers in the foreground, while the trio in the rear consists of Arthur Boland, Fred Binger and R. G. Winter, all of the Columbia forces. Ed. Blimke, of the Chicago office, was off fishing while the picture was be-

"The last word" in re-creation of music. Produced by the

## "Orotund" Sound-Box

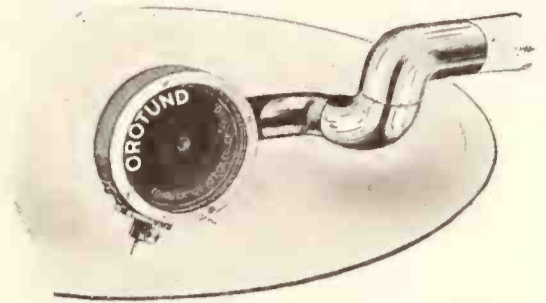

Dealers should handle the "Orotund" outfits to make their machines universal in playing all records. Sample price to dealers \$3.50, cash with order. Please mention make of machine when ordering.

COMBINATION ATTACHMENT CO.  
524 Republic Bldg. CHICAGO, ILL.

ing taken and W. W. Parsons, a former Columbia man, but now of the FlexiFile Sales Co., was operating the camera.

#### Talking Machine Shop's New Home

The Talking Machine Shop will occupy its new home at 234 South Wabash avenue, around the first of September. Though the whole building is leased by the company only two floors will be occupied by them. On the first floor there will be a reception room, record sales, and record stock room. The machine sales room will be on the second floor in addition to six more record sales rooms, office, and reception room.

#### Lyon & Healy Field Day

Six hundred store and factory employees of Lyon & Healy and all the officers and department heads took Ravinia Park by storm Saturday, July 29. Transportation and all expenses were borne by the house, and a delightful lunch was served in the casino and on tables spread under the trees. In the afternoon a magnificent concert by the famous Chicago Symphony Orchestra was enjoyed, and after that everybody adjourned to the magnificent athletic field where the baseball enthusiasts of the talking machine and sheet music departments, joined battle in a contest to decide the supremacy. As is usual in many such contests, the victory did not come to those who were in the lead at the start, and the skillful battery enabled the "Victrolas" to carry away the laurels. During the luncheon Miss S. G. Lessick, of the Victor record department, sang, and the L. & H. saxophone quartet gave several numbers.

Those who stayed for the evening concert had the pleasure of hearing Mabel Garrison, of the Metropolitan Opera Co., and whose Victor record of the "Doll Song" from the "Tales of Hoffman," and which she has sung at Ravinia, is meeting with a big sale.

#### "PlayRite" Motors in Demand

The American Phonoparts Co. reports a re-  
(Continued on page 75)

#### THE COVER WITHOUT A CATCH

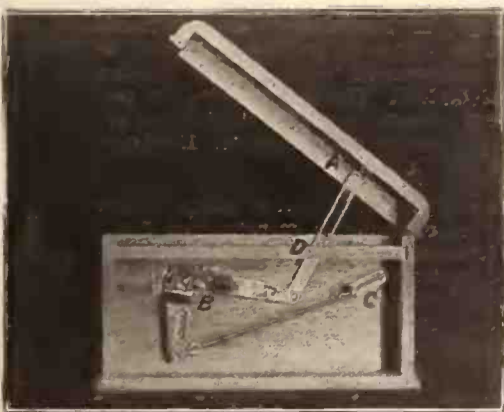

Showing How It Operates

## THE COVER THAT NEEDS NO CATCH

IT needs no catch simply because it catches itself. That is, it is self-controlled. Its own weight, reacting upon itself through simple mechanical principles, robs it of its weight. Thus it makes fingers, records and the top itself safe from being shattered by dropping.

Simple, safe and easily applied. An effective talking point and a great feature.

CHICAGO HINGED COVER SUPPORT & BALANCE CO., 144 S. Wabash Ave., CHICAGO

# The Mandel Phonograph

## A New Entry

It is not an ordinary talking machine, nor is it an assembled product constructed merely to sell.

But the MANDEL Phonograph is a high-grade instrument, every part of which is made by us in our big phonograph factories in Benton Harbor, Mich., and Chicago, Ill.

Yes, it's a masterpiece, not only in craftsmanship but in its performance as well.

The dealer who understands the value of consumer service, has a strong grip on the underlying principles of successful selling.

Consumer service is what you give with the MANDEL Phonograph. Its chief appeal is low price to the consumer, yet low price that is consistent with high quality—quality which demonstrates that not a detail was overlooked in making the MANDEL a Phonograph that is good to the eye and ear.

And for the dealer the MANDEL line earns profits unusually large. This is prompted by a liberal policy that will secure the right kind of co-operation between us and our dealers—co-operation that spells large sales and mutual profits.

Beauty, massiveness, refinement, true reproductive powers—these and more we claim for the MANDEL Phonograph.

Our exceptional equipment has enabled us to prepare adequately—we can actually make immediate deliveries.

Write for further details and our liberal terms.

**The Mandel Manufacturing Co.**

General Offices:

DEPT. A

501-511 LAFLIN STREET, CHICAGO, ILL.



**Mandel, No. 2**

Price, with Spring Motor.....\$30.00  
Price, with Electric Motor..... 45.00

Cabinet in genuine mahogany or quarter-sawed oak. Size of cabinet is 20 inches long, 15½ inches high, and 17 inches wide. Equipped with spring motor or electric motor. Has 10-inch turntable.



**Mandel, No. 3**

Price, with Spring Motor.....\$ 90.00  
Price, with Electric Motor..... 105.00

The size of this cabinet is 48 inches high, 23 inches deep, and 32 inches wide. Made in genuine mahogany or quarter-sawed oak. Special finishes if desired. Has two shelves for record albums and fifty individual upright record compartments. Hardware highly nicked.

Equipped with double spring motor or electric motor operating on direct or alternating current and on all voltages from 100 to 125, also 200 to 250 volts. 12-inch turntable. Equipped with tone graduator for increasing and diminishing the volume of sound. Reproducer, tone arm, sound chamber, speed regulator, brake—are all that can be desired in a high-grade phonograph.

# GET THIS CATALOGUE →

before you take a step toward selling Talking Machines

Competition is keen in the Talking Machine field, and the EMPIRE is the one machine that can cut out competition for you.

This beautiful, instructive book describes our entire novel dealer proposition, and the finest, biggest values, most profitable line of Talking Machines ever put out—the

## EMPIRE

the machine that plays any record

The EMPIRE has every improvement found on any Talking Machine, and many exclusive features. These, together with the wide selection of models and prices, make the EMPIRE the easiest and quickest selling machine in the field.

Don't delay—for the sake of your prestige and profits send for a copy of this Catalog now.

Just ask us to send you our new catalogue of EMPIRE TALKING MACHINES and complete information regarding our proposition and real dealer helps. There is no obligation on your part.

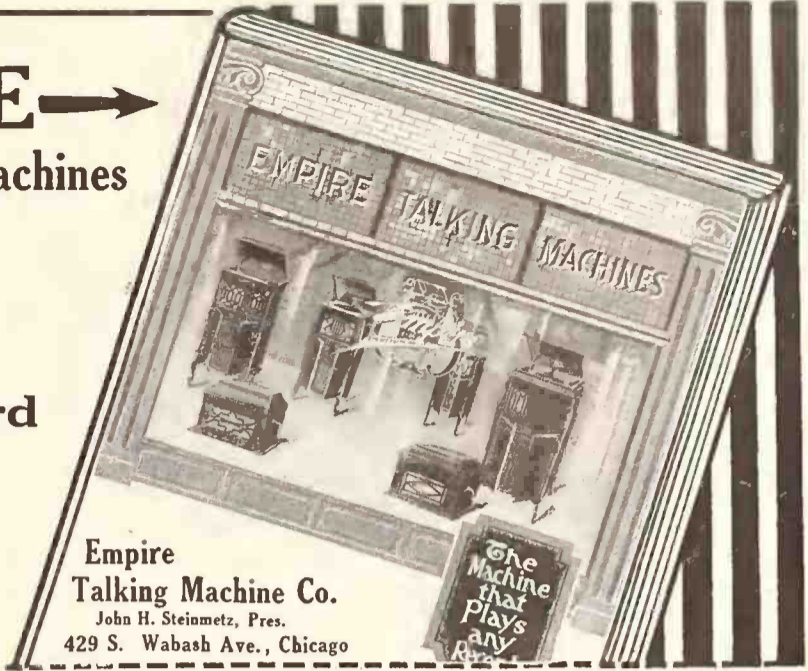

Empire  
Talking Machine Co.  
John H. Steinmetz, Pres.  
429 S. Wabash Ave., Chicago

### FROM OUR CHICAGO HEADQUARTERS—(Continued from page 73)

markable increase in interest upon the part of the trade in its "PlayRite" electric motor. "The trade seems to be more optimistic than ever over the future of the electrically driven phonograph and our business in this direction is increasing very rapidly," said S. S. Schiff recently. "Our motor attains an even, steady speed without making condensers or transformers necessary. No rheostats are necessary to regulate its speed. We claim that it eliminates spring troubles, is noiseless, will not blow fuses and costs but a cent a week to operate. Those manufacturers who are equipping with the electric motor seem satisfied that they are building for the future in marketing an electric-driven machine. As for ourselves we have unbounded faith in the electric's future and, of course, in the future of the 'PlayRite' motor in particular." An interesting announcement from this company appears on page 77.

#### Exhibits at Furniture Show

There were quite a few talking machine exhibits at the furniture show in the big permanent building on Michigan avenue last month.

The Vitonola Talking Machine Co. had an extensive showing of their line and opened a number of new accounts as a result.

The Wisconsin Chair Co., of Port Washington, Wis., showed the new Dennett talking machine named after the president of the company. An unique feature is that the machine is so constructed that the record files are in the upper part of the cabinet making it possible to procure and replace them without bending. Unusual size and length of horn and consequent volume and sonority of tone is claimed. Other exhibits were those of the Lyrphone Co., of New York, and of Schram Bros. and M. J. Foyer, both of Chicago.

#### B. B. C. Conference

The Brunswick-Balke Collender Co. held a big conference at their Muskegon, Mich., factories last week. Over a hundred and fifty department and sales managers from all over the country were in attendance. They were shown through the phonograph and other plants and listened to lectures by superintendents and technical men.

Special attention was naturally given to the Brunswick-Pathé phonograph, as this is one of the company's latest and most important departures. Martin Nystrom, manager of the talking

machine department, gave a whole day to the crowd which was very enthusiastic over the exhaustive demonstrations of the Brunswick-Pathéphone and Pathé records. The constructional and acoustic features of the machine were fully explained and sales campaigns formulated.

The company is preparing to open handsome and well equipped wholesale and retail ware-rooms on the ground floor of a building a few doors north of the company's general offices at 623-33 South Wabash avenue. Ivan L. Webster, who has been with the Pathé since the line was opened in Chicago, is in charge of the record department.

#### Personals

C. E. Goodwin, general manager of the Phonograph Co., after spending several days in Charlevoix, Mich., golfing with Gustave Babson, has gone to Duluth to finish up his vacation. He will return about the 19th. When he returns, his assistant, D. L. Dubois, will go on an automobile trip among the fishing grounds of Wisconsin. Wm. H. Guild, wholesale traveler for the Phonograph Co., is spending his vacation in Michigan. A. D. Wayne, retail manager, leaves next week for a fortnight's vacation at Eagle Lake, Wis.

Charles F. Winegar, general sales manager of the Chicago Hinge Cover, Support and Balance Co., has returned to Chicago after a sojourn among Eastern trade during which he had his headquarters at the New York office. Mr. Winegar will spend some little time visiting important prospects in the West and for the present can be reached most directly at the Chicago office. The company has made splendid progress with its specialty which is now being incorporated in the product of about a score of talking machine manufacturers.

George Davidson, of the Talking Machine shops, is accompanied by his wife and several friends on an auto trip to Denver. He is expected back about the 15th of the month.

S. O. Wade, of Wade & Wade, makers of the Wade fibre needle cutters, spent considerable time in the East after the jobbers' convention. He was accompanied by Mrs. Wade, and they were the guests at Buffalo for several days at the home of B. M. Andrews, of the house of W. D. Andrews. Distributors in New York, Philadelphia, Boston and other points were visited, and some excellent orders for the firm's product secured. Mr. Wade is now in Iowa.

Will Knabe, vice-president of the Knabe Bros. Co., of Cincinnati, O., makers of the Knabe-Crystola line of talkers, was in Chicago this week in conference with Al. Bruckner, local representative.

Fred A. Siemon, manager of the talking machine department of the Rudolph Wurlitzer Co.'s Chicago branch, is on a vacation that he is spending at Delavan Lake, Wis.

George Chopin, manager of the talking machine department of the Bry-Block Mercantile

(Continued on page 77)

# Majestic PHONOGRAPHS

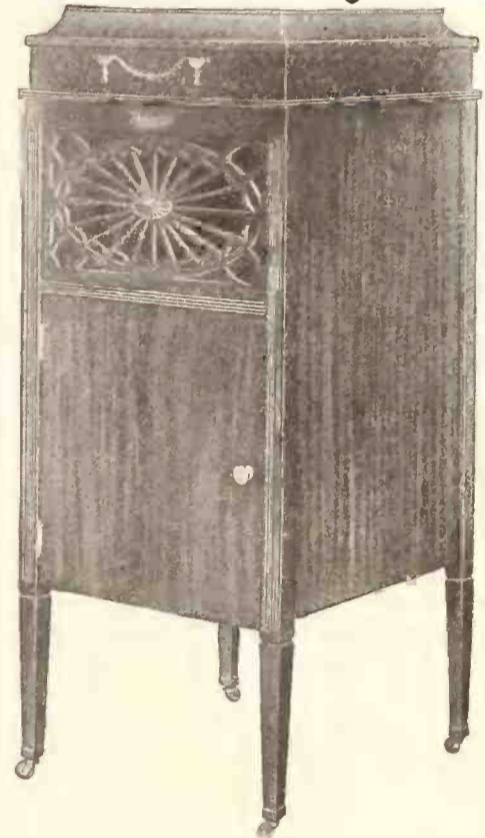

"MODEL J" \$100, (Electric Motor)

## 8 Eight New Patented 8 IMPROVEMENTS 8

affecting every vital part of a Talking Machine and reproduces perfect disc records of all makes.

#### NATURAL AS LIFE

The Majestic improved features are

- No. 1. MAJESTIC REPRODUCER  
*"Natural as Life"*
- No. 2. MAJESTIC "SURFACE" SILENCER  
*eliminates scratching*
- No. 3. MAJESTIC ADJUSTABLE TONE-ARM  
*plays any make disc record.*
- No. 4. MAJESTIC AUTOMATIC-STOP  
*correct and positive.*
- No. 5. MAJESTIC MODULATOR  
*does not choke nor muffle.*
- No. 6. MAJESTIC DOUBLE & TRIPLE TONE-CHAMBERS  
*Tone voluminous, not tense.*
- No. 7. MAJESTIC REVOLVING RECORD FILING SYSTEM  
*easy to reach.*
- No. 8. MAJESTIC ELECTRIC MOTORS  
*adaptable any current.*

Prices: \$50, \$75 Spring Motors  
\$100, \$150, \$200, Electric Motors

Dealer's territories now being allotted

Built by

**Majestic Phonograph Co.**

McClare Building 218 S. Wabash Avenue, Chicago

## For REPAIR PARTS

OF ALL KINDS WRITE ME

at my new location

180 North Dearborn St.

CHICAGO

Repair parts bought and sold.  
Expert Repairing a Specialty.

**Charles Bryan**

## Dealers Who Sell Small Machines—

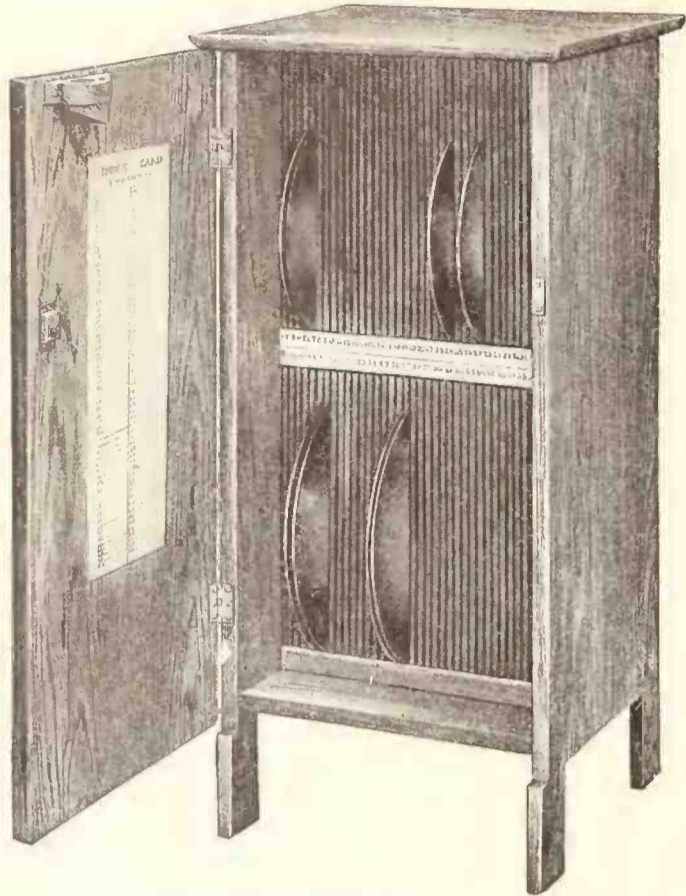

No. 752—Cabinet 35 inc. high. Top 17 x 17 in. Felt-lined compartments holding 72 records. Wood rack compartments holding 132 records. Index system, needle holder, etc. Used for small machines generally. Finished in Oak or Mahogany.

*Should* and *can* easily make large additional profits by disposing of a SALTER cabinet with every machine sale.

Machine owners must have a place to put records and they must have something to set the machine upon.

They realize that and think of it at once. Here is where the cabinet sale comes in and invariably it comes quickly!

There is nothing easier to sell in a situation of this sort than a good cabinet and especially one of the

# Salter Felt-Lined Cabinets

They come in a large number of styles and sizes and in different finishes.

There is no small machine that a SALTER cabinet will not accommodate. There is no machine that is too good for a SALTER cabinet and there is no purchaser who is not impressed immediately with SALTER quality.

Here are two styles that fairly sell themselves.

Wake up your salesman on this, get our catalogs and start right in!



No. 166.—Height, 30 in.; top, 25 x 20 in. Records can be laid on front when open. Felt-lined compartments hold 52 records. Wood rack holds 96. Any color in Mahogany or Oak.

# SALTER MFG. CO.

337-349 N. OAKLEY  
BLVD.

CHICAGO

ORIGINATORS OF  
FELT-LINED CABINETS

FROM OUR CHICAGO HEADQUARTERS—(Continued from page 75)

Co., of Memphis, Tenn., and E. T. Anderson, of the Cable Music House, of Rock Island, Ill., were recent visitors to the local talking machine trade.

H. R. Fitzpatrick, Lyon & Healy traveler in Michigan and Indiana, and H. Royer Smith, L. & H. booster in Illinois, are back in their territories following enjoyable vacations. J. E. Meagher, Lyon & Healy ambassador in Wisconsin, is spending a vacation in the East.

Rumors are around that Frank Johnson, of the Talking Machine Shops, is to be married ere long. The only possible clue to the lady's name is found in the fact that the young Romeo is always playing a record with something in it about "Marguerite."

Edward Williams, Bloomington, Ind., and Mr. Rix, of the Rix Furniture Co., of Big Springs, Tex., were members of the trade visiting the Great Central Market a few days past.

Messrs. Callahan and Kendrick, Pacific Coast Victor travelers, stopped in Chicago recently en route to Camden.

L. C. Wiswell, head of the Lyon & Healy talking machine department, followed up his work at the convention with a little rest that included a motoring trip through Indianapolis, Columbus, Cleveland, Toledo and back home.

J. B. Ryde, assistant manager of the L. & H. department, is on a vacation to White Lake with his family.

**Mandel Brothers Establish Department**

The firm of Mandel Brothers, one of the best-known of the State street department stores, has established a talking machine department, and has taken on the full line of Columbia machines and records. The section will be located on the ninth floor and will be in charge of Mr. Ling, who announces that the department will be formally opened about the middle of this month. In addition to the Columbia line the Starr, Little Wonder and Emerson records will be carried. The Stewart is to be carried in the toy department.

C. R. Ely, who negotiated the deal for the Columbia Co. is to be congratulated upon establishing the line with such a large institution.

**Playerphone Making Progress**

The Playerphone Talking Machine Co. of Chicago, has been making rapid progress since its inception and visitors to the offices in the Republic Building have been surprised with the activities to be seen there. In a little talk with D. W. McKenzie, the president of the company, he said, "We are opening some very large assembling rooms at 21-23 South Wabash avenue, and all five factories making cabinets for us will ship in here. We are delivering at the rate of fifty to a hundred a day.

"Williams-Davis-Brooks & Hinchman Sons, wholesale druggists, of Detroit, Mich., are meeting with great success jobbing the Playerphone. We have several traveling men on the road, shipping them from one to a hundred instruments monthly. The Oklahoma Book Co., of Oklahoma City, Okla., is doing the same thing. The J. W. Crowder Drug Co., of Dallas, Tex., has a monthly demand as large as the two preceding companies. We closed up with quite a number of other large distributors, one in Indianapolis and several on the Western coast. The Playerphone in a very short time will be equipped with an automatic stop. We have also made improvements on our electric motors that we are going to equip our instruments with by next month."

**Opens Offices for Crescent Co.**

The Crescent Talking Machine Co., of New York, will have representation in Chicago from now on, as Wm. R. Everett has opened offices in Suite 502, 23 East Jackson boulevard, and is pushing the line in such fashion as to insure its being a factor in the local trade ere long. Mr. Everett has had wide experience in manufacturing and selling, and while in his past connections showed a wide knowledge of the talking machine field. The Crescent line ranges in retail price from \$12.50 to \$200.

**Brings Out New Automatic Brake**

The Perfect Automatic Brake Co., of this city, has entered the market with an automatic brake. The stop is somewhat similar to other brakes and is set by simply moving the tone arm to the inside as far as it will go and then setting the stop at the place desired. The stop is said to be very easily attached, simple to operate and can be used with any machine.

**MANDEL MFG. CO. IN THE FIELD**

**Prominent Manufacturers Enter Into the Manufacture of Talking Machines**

CHICAGO, ILL., August 5.—The Mandel Manufacturing Co., of Chicago and Benton Harbor, Mich., recent entrants into the field of phonograph manufacture, has completed both its organization and its product and has started in upon a powerful campaign for the fall trade.

The company acquired some time ago the



Mandel Manufacturing Co.'s Chicago Plant large plant formerly occupied by the Spencer Barnes Co., manufacturers of high-grade furniture at Benton Harbor, Mich., and the splendid equipment which that plant was possessed of is seen in the construction and finish that characterize the first of the Mandel machines to be shown.

The Mandel Co. is in a favorable position in that its instruments are not assembled products.

(Continued on page 79)

**Phonograph Manufacturers—**

we have "Just what you are looking for"

**"PLAY-RITE"  
Electric Phonograph Motors**

Simple and substantial. Praised by all who have seen it.  
Can be installed by any ordinary workman.

**PUSH THE BUTTON—The "Play-Rite" Motor Does the Rest**

**Seven Reasons why you should use Play-Rite Motors:**

- 1st—Price about the same as an ordinary spring motor.
- 2nd—No more winding.
- 3rd—No more spring troubles.
- 4th—Cost less than one cent per week to operate.
- 5th—Guaranteed not to burn out or blow fuses.
- 6th—Guaranteed to run steady regardless of variation in electric current.
- 7th—Motors are furnished complete with 12-inch turn-table, speed regulator, 10 feet of cord, plug and switch ready for installation. Furnished for either Direct or Alternating Current. Quick Deliveries.

**The "PLAY-RITE" Universal Tone Arm**

is the one and only device that possesses all of the advantages and none of the annoyances of other tone arms.

Will Play Any Record  
MANUFACTURERS who are making talking machines should investigate this device.

HIGH GRADE SPRING MOTORS on hand for immediate delivery.

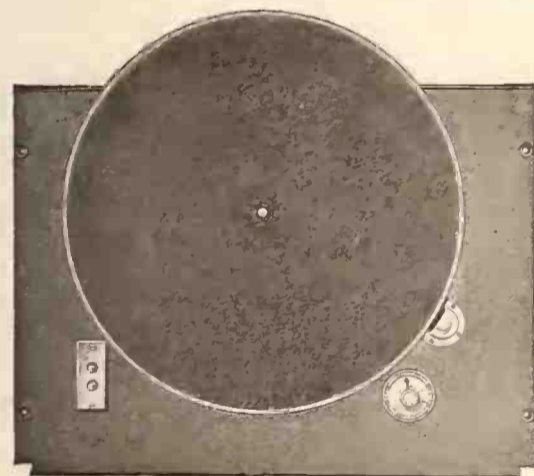

Top View

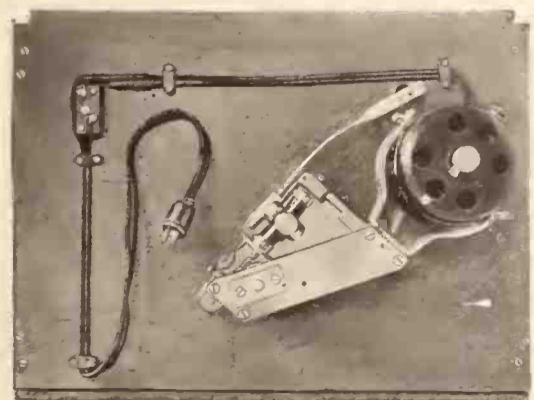

Bottom View

Showing method of mounting on motor board

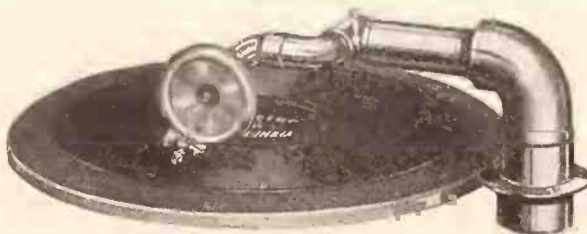

**American Phono-Parts Company**  
208 South Wabash Avenue  
Chicago

## DEALERS—A THOUSAND MORE WRITE OR WIRE US NOW For the Brunswick-Pathephone Agency

OUR first announcement of the new Brunswick-Pathephone and Pathé Disc Records has created a stir throughout the trade that probably has no equal. Telegrams and letters came from dealers everywhere. Hundreds applied for the agency of this revolutionary line.

Now heavy advance orders are coming daily. And we shall soon be ready to start the initial shipments.

But please remember this—our first allotment is limited. Those who secure this agency at once will be in a strong position to make a flying start when our impressive campaign of advertising starts this fall throughout the nation.

Never have values like these been known before on high-class phonographs. And Brunswick's leadership as the maker of fine cabinets plus Pathé attainments in Records and Reproduction—these two great forces bring a companion proposition that experts predict will dominate the field.

## Brunswick-Pathephone and Pathé Records

Write us today for full particulars. See the beautiful models, the wonderful cabinet construction, the marvelous attainments in sound box and tone chamber. And get our low prices and trade-winning offer to one good live merchant in every city and town. No obligation. Don't be late.

**The Brunswick-Balke-Collender Co.**

Brunswick-Pathephone Department 203

623-633 S. Wabash Avenue :: Chicago

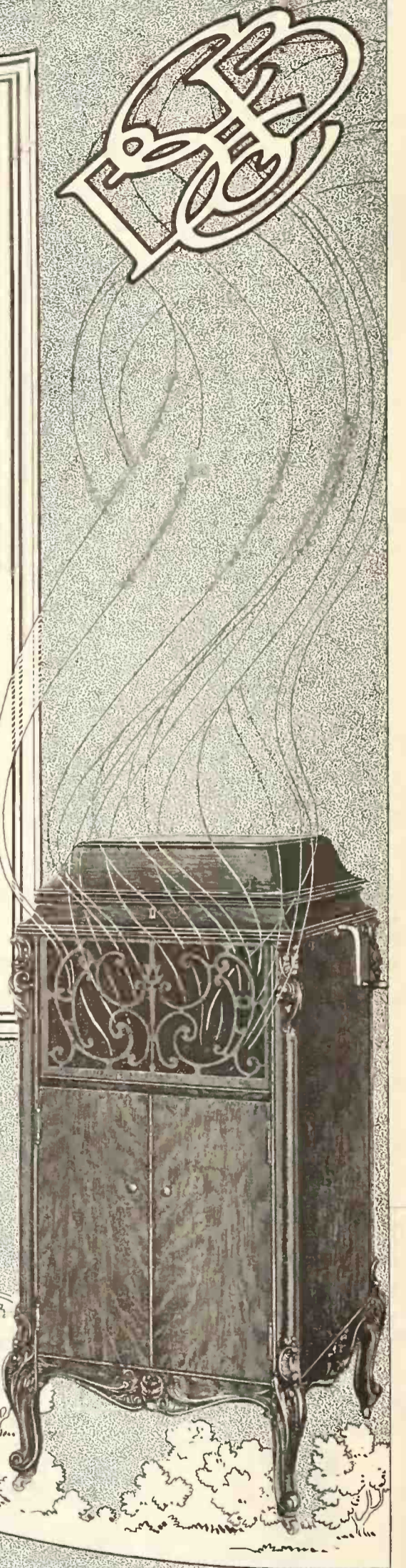
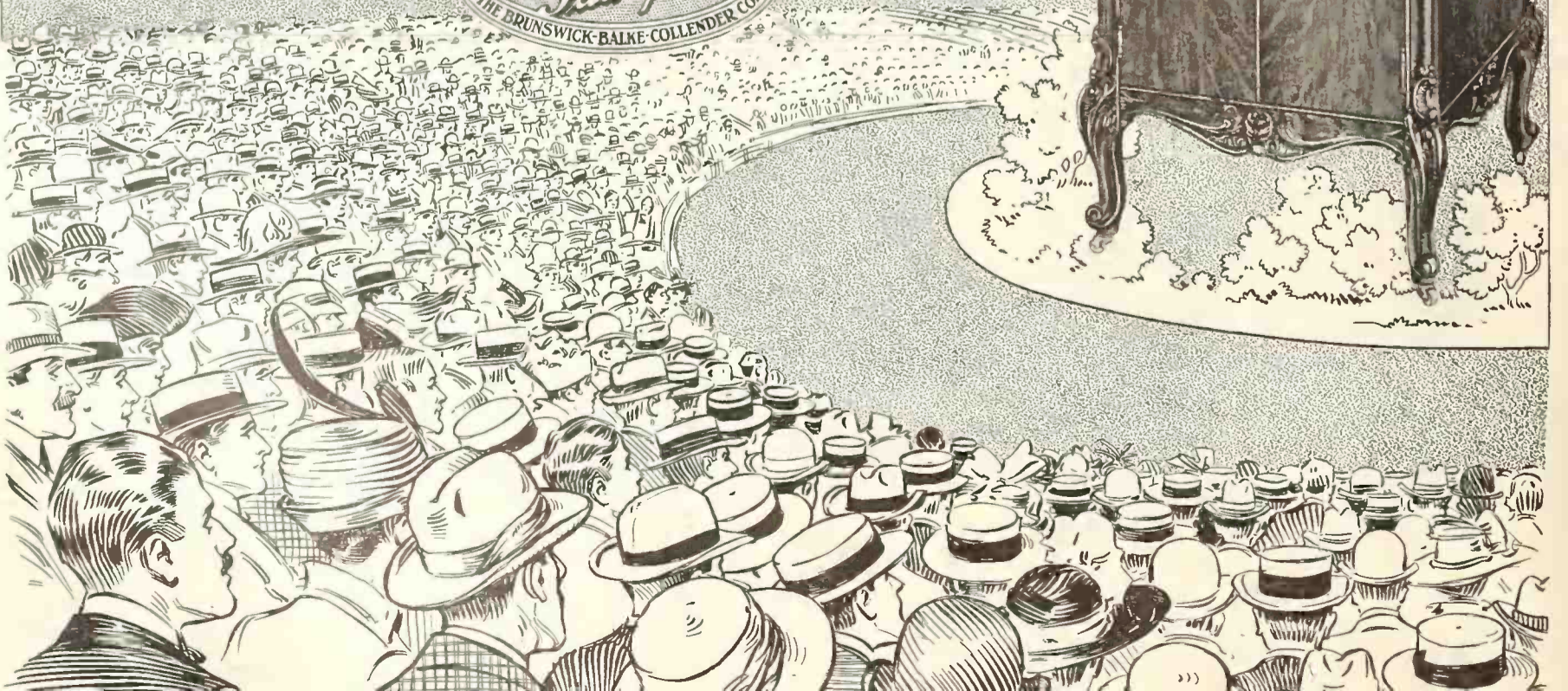



FROM OUR CHICAGO HEADQUARTERS—(Continued from page 77)

but are manufactured in their entirety, including the manufacture of all metal parts in the Mandel factories.

In addition to the styles equipped with spring motors the company is bringing out two styles that are to be equipped with electric motors.

The proprietors of the Mandel Manufacturing Co., Messrs. M. and L. Mandel, have been in the manufacturing business over ten years, and they have been, and still are manufacturing cameras and photographic materials under the firm name of the Chicago Ferrotyping Co. The rise of this company from an insignificant beginning to its

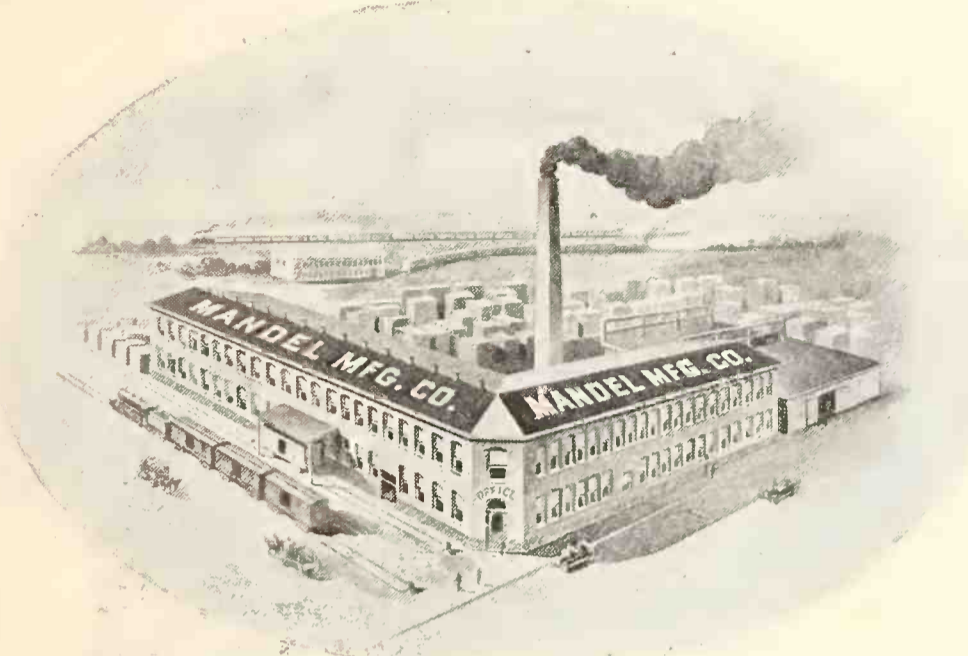

Mandel Manufacturing Co.'s Factory at Benton Harbor, Mich.

endeavor. The general offices of the company are located at the Chicago plant at 501-511 South Laflin street.

**TO FEATURE FIBRE NEEDLES**

The B. & H. Fibre Manufacturing Co. Seeks a Broader Market and Re-Establishes Direct Communication With the Trade

CHICAGO, ILL., August 7.—The B. & H. Fibre Manufacturing Co., 33 and 35 West Kinzie street, the patentee, owner and manufacturer of the fibre needle, announces that after six years it is again able to re-establish direct communication with the trade. For the past six years it has made its product exclusively under the name

of the Victor fibre needles and Columbia fibre needles. It will still manufacture as in the past for these companies but will also produce fibre needles under its own "B. & H." label.

F. D. Hall, the president of the company, and who invented the fibre needle and placed it on the market a decade ago, has been tireless in his efforts to bring it to the highest point of perfection. A large force is employed in the factory on Kinzie street, and new machinery of special design is constantly being added. The merits of the fibre needle are recognized

by the trade all over the country. In many stores salesmen are instructed to demonstrate with fibre needles not only because of the character of the tone secured and the absence of scratch, but also because they do not injure the records.

**C. E. ELTING CO. IN MOTOR FIELD**

Well-Known Spring Manufacturers Enter Talking Machine Trade and State They Are Ready to Make Motor Deliveries Immediately

CHICAGO, ILL., August 1.—The Charles H. Elting Co. has made formal announcement of its entry into the field of talking machine manufacture. In discussing the move, A. O. Elting said: "About all that we can say is that we equipped ourselves to manufacture motors the early part of May and are now ready to make deliveries. Our reason for venturing into the phonograph motor manufacturing business is that we are spring manufacturers and have for years supplied motor springs. When the present stringency of the market took place and everybody wanted springs, we could not help but feel that it would be more advantageous to use our own springs and put them into motors. This is our sole reason for having gone into the motor manufacturing business. We have unlimited facilities for any quantity of business we may get. We have all the raw material we may require and are in a position to take care of any business which may be offered to us."

**A NEW RECORD FILING SYSTEM**

Number of Commendable Features in New Filing Cabinets Intended for Use in Homes

CHICAGO, ILL., August 5.—A new record filing system Richmond has entered the field. The FlexiFile Sales Co., of 327 South LaSalle street, is placing on the market a patented method of storing records for instant use in the home,

(Continued on page 81)

**How is This for Value?**



**Style 100 International**  
Stands 48 inches high, 20 inches wide and 22½ inches deep. Mahogany or oak.

We claim that one of the best values in the talking machine trade today—both to the retail buyer and the dealer—is in our Model 100

**INTERNATIONAL**

**\$100 RETAIL**

It is finished artistically in choice mahogany or oak, equipped with fine quality nickel-plated metal parts and a powerful motor that can be wound while playing. Speed regulator and indicator. Equipped with jeweled needle to play hill and dale records. We also supply 200 steel needles for use with lateral cut records.

*Our line ranges from \$15 to \$200 retail.*

**Get our Catalog**

**International Talking Machine Co.**

**1719 West Van Buren Street**

**Chicago, Ill.**

# FlexiFile DISC RECORD CABINETS

Devised by Business System Experts Combining Greatest Capacity with Perfect Accessibility



FlexiFile No. 1—(Closed)  
Capacity 75 Records—10 or 12 inch  
RETAIL PRICE, \$15.00

THESE cabinets, made in three models, are especially adapted for machines ranging from \$5 to \$35 in retail price.

When a record is wanted, the top, with machine, slides to one side exposing contents of entire record receptacle. Our patented FlexiFile system, illustrated below, gives double the storage capacity of other systems. There are no albums—no wooden partitions or shelving.

Records do not come in contact, cannot break or mar, double-faced records are instantly located by a perfect alphabetical and numerical index.



FlexiFile No. 1—(Open)  
Capacity 75 Records—10 or 12 inch  
RETAIL PRICE, \$15.00

RECORD INDEX						
No.	A	TITLE	No.	TITLE	No.	TITLE
1			1		1	
2			2		2	
3			3		3	
4			4		4	
5			5		5	
6			6		6	
7			7		7	
8			8		8	
9			9		9	
10			10		10	

THE RECORDS ARE INDEXED ALPHABETICALLY AND CROSS-INDEXED NUMERICALLY. SEVEN TO TEN GUIDE CARDS NUMBERED CONSECUTIVELY ARE PLACED IN EACH CANVAS POCKET. EACH RECORD IS INDEXED ALPHABETICALLY ACCORDING TO ITS TITLE AND GIVEN A NUMBER, AND FILED IN FRONT OF THE CORRESPONDING NUMBER SHOWN ON INDEX TAB OF GUIDE CARD. IN THE CASE OF A DOUBLE-FACED RECORD, IT IS INDEXED ALPHABETICALLY TWICE ON THE INDEX CARD, BUT BOTH TITLES CARRY THE SAME NUMBER.

The FlexiFile is an exclusive system fully covered by U. S. and Canadian patents.

It is revolutionizing record filing as it has office work.

NOTHING TO HANDLE EXCEPT THE PARTICULAR RECORD THAT IS DESIRED—THE PLACE FROM WHICH IT IS TAKEN REMAINS OPEN UNTIL IT IS RETURNED.

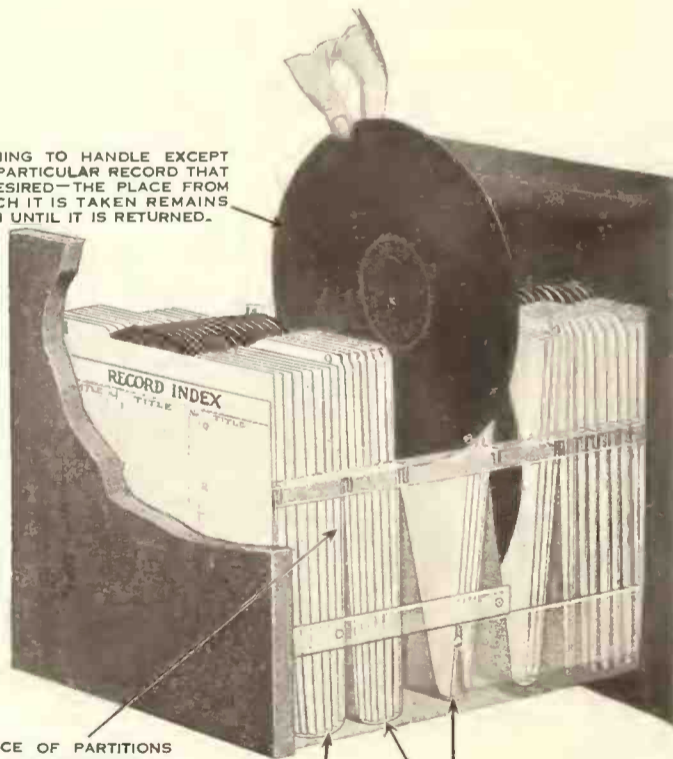

NOTE ABSENCE OF PARTITIONS AND ALBUMS—FULL CAPACITY OF DRAWER UTILIZED. SEVEN RECORDS (INCLUDING GUIDE CARDS) ARE FILED TO EACH LINEAL INCH OF THE DEPTH OF DRAWER.

RECORDS NEVER CHIP OR CRACK AS THEY DROP INTO CANVAS POCKETS.

THE POCKETS OPEN, MAKING RECORDS ACCESSIBLE, OR CLOSE COMPACTLY BY A TOUCH.

## LIST PRICES

Liberal Discounts to Dealers

- (Shown in illustrations.) Extension top, 18" x 18". One filing compartment, capacity 75 records with 75 index guide cards, \$15.00.
- Extension top, 19" x 28". Two filing compartments, capacity 150 records with 150 index guide cards, \$30.00.
- Extension top, 24" x 38". Three filing compartments, capacity 300 records with 300 index guide cards, \$40.00.

Finished in either Mahogany, Fumed or Golden Oak. Cabinets 2 and 3 have Cane side panels.

## SPECIAL LINE

Special cabinets for dealers' stock records. Price on application.

Above prices do not include talking machine shown in illustration.

# FLEXIFILE SALES COMPANY

327 South La Salle Street, CHICAGO

## DISTRIBUTORS:

For Illinois:  
FlexiFile Distributing Co.  
306-7 Webster Bldg.

For New York City, Connecticut, Rhode Island, New Jersey  
FlexiFile Co. of New York, Inc.  
Suite 305, 395 Broadway, New York

We say to you here, and we stand ready to prove it, that Columbia records are *uniformly* the best that your money or your customer's money can buy. Bring the argument down to brass tacks if you like; pick your own point; record material, record surface, record tone, record wear, repertoire, timeliness, artists—any one or all of them!

(Write for "Music Money" a book "full of meat" for those dealers interested in quick and frequent turnover of capital.)

Columbia Graphophone Co.  
Woolworth Building, New York



FROM OUR CHICAGO HEADQUARTERS (Continued from page 79)

which appears to have most commendable features. The merit of the principle involved has already been demonstrated in the world of business and the FlexiFile letter filing cabinets are being used by many large concerns in this and other cities. To adapt the system to the task of caring for disc records was an easy matter, and this was done by President Frank P. Read and W. W. Parsons, a man well known in the talking machine field, who secured an interest in the business and has been elected secretary.

The company is already negotiating with a number of large talking machine manufacturers with a view to the incorporation of the FlexiFile system in their cabinet machines. Not content with this, however, the company is also bringing out a line of neat cabinets of their own for use with the small popular-priced machines, ranging say from \$5 to \$35 retail and of which there are a number on the market.

As will be seen in the illustrations on page 80, the records are kept in a vertical position, but are suspended in canvas pockets or "hammocks" which do not come in contact with the bottom or sides of the filing receptacle. There is no chance, therefore, of the record being damaged should it slip from the fingers. Each pocket contains seven records which are separated from each other by guide cards. The FlexiFile is telescopic, but when a record has been taken out the pocket remains open until it is returned. Only one record need be removed in order to get the one desired.

The alphabetical numerical index is the front-piece, so to speak, of the file proper. By it selections on double-faced records are quickly located.

The FlexiFile record cabinet, which the company is now ready to supply the trade, is made in three models, the storage capacities of which are for 75, 150 and 300 records respectively. The top of the cabinet slides back with the machine on it, enabling free access to the records.

President Read is a man of long experience in organizing and launching important business enterprises and has devoted the last year in the promotion of the FlexiFile proposition.

W. W. Parsons has been associated with the talking machine business since 1893, at that time being associated with the North American Phonograph Co., and in later years was associated with the Columbia Graphophone Co., in 1902 having opened their Milwaukee musical store and later returned to Chicago, where he has been associated with them in executive positions until a short time ago. He is not only secretary of the FlexiFile Sales Co., which controls the FlexiFile for the entire country, but is also president of the FlexiFile Distributing Co., which controls the sales for the State of Illinois.

R. R. Schotta, formerly manager of the Office Equipment Mart, of Chicago, has opened Eastern offices at 395 Broadway, under the title of the FlexiFile Co. of New York, Inc.

A POSTER ON THE VICTOR "STARS"

A large folder that is designed for billboard service and which calls the attention of the public in an effective way to the wonderful galaxy of stars that are making records for the Victor library has been produced by Lyon & Healy in connection with the comprehensive Victor advertising service that the big Chicago house has designed for its dealers. This poster is being syndicated to Victor dealers in all parts of the country so popular has it been with the trade.

Another feature of the service is a series of forty-eight advertisements, four of which are furnished to the dealer in mat form each month. This copy is mainly of the "human interest" variety and in every instance bears out one or more of the manifold advantages of Victrola ownership.

INTERNATIONAL CO. IN NEW FACTORY

The International Talking Machine Co., which was formerly located at 1216 South Jefferson street, has just completed moving into a much enlarged and improved factory and has begun shipments of goods from the new quarters. The offices of the company are now located at 1719 West Van Buren street, while the factory is located on Hermitage avenue, just south of Van Buren street. The offices, however, are directly connected with the factory. Besides the office and storage space there are three floors of factory space, each amounting to 7,500 square feet. New machinery and other equipment is being installed and the company is now able to turn out a remarkably increased number of machines daily.

EQUIPMENT IN NEW SALTER FACTORY

The work of equipping the new Salter factory with woodworking and finishing machinery has been completed and the factory's capacity has taken the expected large increase without any delay.

Indications are that dealers are not to be caught napping on cabinet deliveries this year and A. H. Grim, who was formerly with the Tonk Manufacturing Co., and who now cares for the local business of the Salter Co., reports a large number of orders on holiday goods that are to be delivered immediately.

LYON & HEALY'S SUMMER WINDOW

Every summer Lyon & Healy devote a show window to the unlimited pleasure that a Victrola



An Artistic Vacation Window Display

owner can get out of a machine while at summer resort or in camp. The display occupies the large window at the corner of Jackson boulevard and Wabash avenue, and has been seen and

admired by many thousands of people. In the foreground on both sides, in the shape of a right angle, is a large tank, which is arranged to look like a brook. The bottom of this tank is covered with stones and sand. Darting about in this deep pool are about two dozen large, live brook trout. The sides of the pool are covered with rocks and moss, where the fish at first were wont to hide, in order to keep away from the crowds of people at the window. In the center foreground are a man and a woman in a canoe. The young lady is operating the Victrola, while her escort is furnishing the motive power for the boat. In front of the brook some snipe are feeding, and on a log on the further bank of the brook are a family of mud turtles, while some birds are flying high in the air. This window display has caused considerable favorable comment and many sales.

CRESO ELECTRIC PHONOGRAPH MOTOR

will be ready for delivery Sept. 15th

Can make deliveries of spring motor parts, governor, gears, stampings, etc.



Chicago Recording Scale Company  
210 Spring Street  
Waukegan Illinois

## WHOLESALE TRADE SHOWS BIG GAIN IN ST. LOUIS

Extreme Heat Hurts Retail Sales But Dealers Are Busy Preparing for Unusually Active Fall—Dealers' Association to Discuss Trade-in Values and the Approval System—Election of E. C. Rauth to Presidency Pleases Friends in Home City—Other News

St. Louis, Mo., August 7.—The trade in talking machines is progressing nicely and some high merchandising records are being made, but the latter half of July showed a strong slump in the record business in the downtown stores. For the first time in the remembrance of downtown merchants the Victor Monthly advertisement came and went without a distinct showing in the cash sales. But at that time the mercury was reaching almost 100 daily and the dealers did not blame the customers for not going out of their way for anything even as attractive as new records. It was the same with other lines. There was only a small, steady trade and nothing the dealers could do would stir anything but more heat.

The greatest gains, perhaps, for the month was in the wholesale business. At the Columbia warerooms C. R. Salmon, wholesale manager, said, "we had a whale of a month." Mark Silverstone said, "we have more than doubled previous records." E. C. Rauth, of the Koerber-Brenner Music Co., said for the Victor line, "trade is excellent in all sections of our territory."

The jobbers are strongly of the opinion that a good many dealers are planning not to be caught short of machines next winter, and for that reason are placing very heavy orders early in the season. Most of the orders now being booked are for immediate delivery. The jobbers are quite sure that these orders, as large as they seem, will not help much for the holiday trade, as the retail trade is going forward to such an extent that the stocks that the retailers anticipated for holiday trade help will be eaten up in a hurry when the fall buying begins.

This view is founded on the trade in those sections of the country where the crop money has been cashed in. Also on the fact, which is substantiated by the last Federal Reserve Bank report, that this section of the country is just now coming into its own in the wave of prosperity that swept the Eastern country a few months ago. Almost without exception, crops are good and money is in demand, factories are working overtime and labor is about the only scarce commodity.

### Dealers' Association to Discuss Trade Matters

The Talking Machine Dealers' Association has called its next meeting for the Century Boat Club, which is high on the bluffs on the south side of the city. At this meeting the "trade in" committee will make its report, and from the amount of consideration and discussion given to this question by members, it is believed that the report will be adopted. It probably will set a value of 10 per cent. of the original price on all old style machines that are offered in part payment. Also that the customer must buy a machine priced at at least ten times the amount of this allowance to get full benefit. No arrangement has been made for setting a value on comparatively new machines, this being left for the present to the dealer. But all values put on trade-ins must be reported at once to the secretary who will card index them and report such values to any other dealer who may inquire. This latter method is depended upon to check the evil that arises over pianos and other instruments that are offered as trade-ins.

The record approval committee has not been as successful in reaching more rigid provisions than those now in force, according to reports. The present plan is that the customer must keep at least 25 per cent. of the records taken out and must make returns in twenty-four hours. It is believed that the percentage will be raised to 50 per cent.

### Going After Motor Boat Trade

Retail Manager Philipps at Columbia warerooms, reports exceptional sales of small ma-

chines to motor boat owners and club houses. This season he employed as salesman a man in another trade, but whose passion is the river. He goes to the water at every opportunity and knows all the regulars. He had never tried his hand at selling, but has made good with Columbias as a side line. He has had two or more sales every week and has brought in some customers who bought high priced machines, but his own sales all have been the small ones.

I. J. Goldwasser is the latest addition to the Columbia sales staff.

Mark Silverstone, of the Silverstone Music Co., Edison jobbers, is maintaining his newspaper advertising throughout the summer months by occasional remarks in facsimile penmanship, personally signed and carried under his picture. Mr. Silverstone is already beginning to mention a forthcoming tone test in his advertising, although it will not be given until some time in October. He says that the crowd for this already is assured.

### Congratulations for Secretary Rauth

E. C. Rauth went North for a vacation after attending the meeting of the Talking Machine Jobbers' Association at which he was elected president of that body. There was considerable inquiry for him here after the Talking Machine World had brought the report of the meeting, as many dealers, including those in other lines than the Victor, which is Mr. Rauth's special study, wished to offer their congratulations to him and also to the association. When Mr. Rauth got home the first of the month he found an accumulation of business and affairs awaiting him, so that he has had little time to give attention to affairs of the future. He found a good many things concerning the local Talking Machine Association, of which he has been one of the active members, that had been postponed until assured that he would be here to attend the meeting.

## ENVELOPES

are far superior to wrapping paper for wrapping records. Your customers will appreciate this kind of package more than you imagine. We make them of gray or brown kraft with string and button fastener, either printed to your copy or plain. Try our corrugated paper packing boxes. Samples upon request.

J. L. GILLESPIE CO., Pittsburgh, Pa.

Manager Irby Reid, of the Columbia Co., was at Memphis the first of the month for several days.

H. A. Yerkes, district manager of the Columbia line, was here from Chicago for several days the first of the month reviewing the local situation.

Manager Hallahan, of Aeolian Hall, talking machine department, was glad to get away early this month for a vacation. The hot season, it seems, has been more wearing on the Aeolian-Vocalion staff than on the trade. As a last word Mr. Hallahan expressed amazement that the machine trade had continued into the hot season and quoted this as the progress the Vocalion was making and the hold it was gaining on the St. Louis public. At Aeolian Hall considerable pride is taken in the service department, and this feature is said to have sustained the record sales at a very high mark through the heated season.

### NEW TYPES OF TONE ARMS

The Consolidated Phono Parts Corp., New York, has just placed on the market two types of universal tone arms. According to its present plans the company will have a line of four styles of these tone arms, all of which will be ready in the near future. During the past few weeks the company's sales staff closed a number of important deals for the various parts it manufactures, including two motor deals, totaling many thousands of motors.



## PERSONAL SERVICE

The members of our Company are always available and will gladly see you personally or write you at any time we can possibly serve you.

Why not communicate at once with us?

**BADGER TALKING MACHINE CO.** 135 Second Street  
MILWAUKEE, WIS.  
VICTOR DISTRIBUTORS

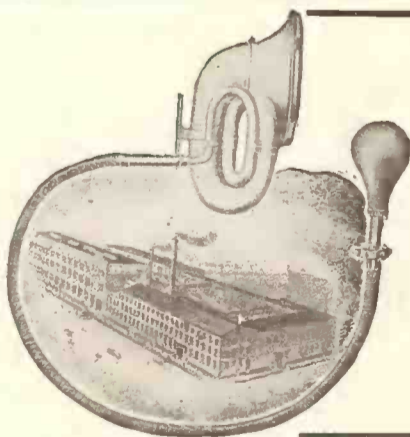

## TONE ARMS TURNTABLES

For many years we have been the only manufacturers of good metal phonograph horns, and recently we have added equipment for making Tone Arms and Turntables of highest quality.

These products are made to your specifications only. Ask for estimates.

Phonograph  
H O R N S **Standard Metal Mfg. Co.**  
227 CHESTNUT STREET NEWARK, N. J.



## THE PREMIER CABINET CO.

Makers and Distributors of the

*Premier*

TALKING MACHINES and CABINETS



CHICAGO, ILL.  
WILLIAMSPORT, PA.  
GOSHEN, IND.

Williamsport, Pa.

## THE FLOAT THAT MADE ADVERTISING MEN ENTHUSIASTIC

The winning by the Victor Talking Machine Co., of the silver cup offered for the best float in the parade held during the recent convention of the Associated Advertising Clubs, in Philadelphia, was told in all reports of the convention, published in all sections of the country and proved a means of publicity well worth the effort put in designing and arranging the float in question. That one of the country's largest

portions. Lights hidden in channels on each side of the float, similar to the foot lights in the theatre, and supplied by current from storage batteries, kept the float brilliantly lighted through the line of march. The second section

Towering over everything was the Victrola. Almost as high was an heroic figure in armor of Die Walküre—at the rear an equally heroic figure of Lohengrin. There were Siegfried, Aida, Tosca, Mme. Butterfly, Faust and Pagliacci, Parsifal, Bohème and many others. Then, to emphasize the universality of Victor music,



Prize Winning Display of Victor Co., in Advertising Clubs' Parade

advertisers secured the award is a matter of particular interest. The attractiveness of the float, which is illustrated herewith, indicates that the judges could not be far wrong in presenting the prize as they did.

For the first section of the float, one of the Victor Co.'s big Packard trucks was covered with a platform hidden under white cloth with valances reaching close to the ground on each side. On the platform the Victor trade mark, dog and all, was reproduced in mammoth pro-

of the exhibit consisted of a wagon used to transport scenery and covered with a platform measuring twelve by thirty-six feet. The float was also lighted as was the first one, with the addition of four automobile searchlights playing on the Victrola from the four corners of the platform.

On this float were thirty persons in costume—not intended to represent artists, but to be a sort of personification of the opera itself. Here, of course, is magnificent material for a pageant.

there was a chorister to represent sacred music, a violinist and a bandmaster. Vaudeville, and even the "nigger" minstrel music, were represented, though not so prominently.

The characters were costumed and made-up in the Metropolitan Opera House dressing rooms and with the aid of expert costumers. Two pages followed the floats throughout the parade, tossing balloons carrying the Victor advertisement into the crowds.

## TO TAKE RECORDS TO LABRADOR

MONTREAL, CAN., July 31.—Dr. Wilfred Grenfell, of Labrador fame, recently purchased a liberal supply of patriotic and popular Columbia records from Layton Bros., which he will take along with him on his coming trip to Labrador.

# 25¢ MAJESTIC RECORDS 25¢

(VERTICAL CUT)

## DOUBLE DISC RECORDS

### A Business Talk With Jobbers About a 7" Record

It's a changed situation. The demand for a lower priced record is even greater than it was a year ago.

In about three months or sooner the demand will be many times greater than it is today.

Probably the greatest factor in bringing about this change will be the **Majestic Record**.

**Because:** The Majestic Record is 7"

—plays as long as most 10" records  
—qualifies with the best and sells for 25c.

When we put **Quality**—three minutes—and brought the price to 25c—we did something for the trade.

No other record sells with such ease as the **Majestic**. Deliveries in quantity **Now**.

Get in touch with us now—we are ready to "talk turkey" with live dealers where we are not already represented.

**Majestic Phonograph Co., Inc.,**

247-253 West 19th Street  
New York City

# THE TRADE IN NEW YORK CITY AND VICINITY

The local talking machine trade closed a very healthy July, as there was very little evidence of the expected midsummer depression, and the sales totals showed a good-sized gain over last year. August has started in equally as well, and from all indications the coming fall will be a record breaking season for all factors of the talking machine industry.

#### Machine Situation Improving

Machine shipments have improved considerably the past few weeks, although there is still a shortage of the machines retailing at \$75 and \$100, with the usual scarcity of the lower-priced models which always have a big sale during the summer months. The record situation was never better than it is at the present moment, and the distributors are filling practically all

record orders on a 100 per cent. basis. The summer record supplements issued by the various manufacturers have been especially praiseworthy this year, containing a wealth of material suitable for summer presentation. The better class of music has also been well represented in these record supplements and the dealers report a very gratifying demand for these records. In fact they state that this summer's record sales have consisted in the main of the better class of music.

#### Getting Ready for Fall Trade

Quite a number of the local dealers have taken advantage of the summer months to redecorate and refurnish their warerooms in preparation for fall trade. The prosperity of the talking machine industry is well evidenced by

the activities of the trade in this direction, and in all parts of the city carpenters, masons and decorators are busily engaged in improving the appearance of talking machine warerooms, constructing new booths and generally putting the various establishments in order for the coming season.

#### Price Cards Well Received

The new price cards recently prepared by the efficiency department of the New York Talking Machine Co., Victor distributor, have met with phenomenal success, and dealers throughout the country have been ordering complete sets of these cards for use in their warerooms. These cards were prepared in four different designs so that the dealer may choose the design best suited for his particular requirements. The many other dealer helps issued by this efficiency department are continuing to give perfect satisfaction to the company's dealers and have been heartily praised by Victor representatives everywhere.

#### Pleased With Fall Outlook

"July business was very satisfactory," said R. F. Bolton, district manager of the Columbia Graphophone Co., in a chat with *The World*. "Our sales totals were considerably ahead of last year, and would have been much greater if we had been able to receive sufficient merchandise from our factory. The outlook for fall is very gratifying, and we have on hand at the present time more orders for fall deliveries than at any time in the history of this organization. We expect to complete deliveries of these orders during the next two months so that our dealers will be adequately prepared for the fall trade." Mr. Bolton left Monday for a two weeks' trip up State, upon which he will visit the Columbia distributing branches in the various cities included in his territory.

#### Activities of the Local Dealers

A fair idea of the actual status of the local talking machine trade may be gathered from the reports of the dealers in the various sections throughout the city. For example, the stores in the Washington Heights section report a slight depression during the month of July, owing to the fact that so many of their customers leave town for the summer. At the same time, however, these dealers report business considerably ahead of last year, especially in their record departments.

#### Reports From the Washington Heights Dealers

The Secord Piano Co., which recently opened piano warerooms at 3493 Broadway and is handling the complete Pathé line, is achieving very pleasing success with these products. Mr. Secord is making plans for a splendid fall trade and will concentrate to a great extent on the sale of the higher priced Pathéphones.

The Abelowitz Phonograph Co., at 1353 St. Nicholas avenue, which handles the Victor line exclusively, recently redecorated its store and added two new demonstration booths. This company makes a specialty of handling the complete catalog of Victor records, together with a large proportion of the foreign records issued by the Victor Co. Mr. Abelowitz, in comparing this year's business with 1915, stated that the first seven months had shown an increase of over 100 per cent.

The Audubon Grafonola Shop, 3750 Broadway, handling the Columbia line exclusively, reports an exceptionally active summer demand for Columbia records. This shop has been somewhat handicapped by the Columbia machine shortage, but expects to have its stock of machines completely filled within the next week or two.

Summer business at the Edison Shop, 160th street and Broadway, has been fully up to expectations, and preparations are being made for a healthy fall trade. This store is one of

(Continued on page 86)

## BRUNO The House Reliable

ESTABLISHED 1834



**S**ERVING the dealer only  
has always been our  
policy — not an innovation.

**C. BRUNO & SON, Inc.**

*Victor Distributors*

351-353 Fourth Avenue

NEW YORK

**WE DO NOT RETAIL**

**DID IT EVER OCCUR  
TO YOU JUST WHAT  
AN EXCLUSIVE WHOLE-  
SALER MEANS TO YOU?**

---

---

**New York Talking Machine Company**

119 WEST 40th STREET

NEW YORK, N. Y.

## TRADE IN NEW YORK AND VICINITY

(Continued from page 84)

the most attractive retail establishments on upper Broadway, being decorated and furnished along the most up-to-date lines.

The Daly & Cool Music Shop, 556 West 181st street, handling the Victor and Columbia lines, recently added three new demonstration booths for their store equipment, and generally rearranged their warerooms to accommodate these new booths. The appearance of the store has been greatly improved the past few weeks, and in its present shape every convenience is afforded visitors and prospective purchasers.

The recently opened Pathé Shop, at 3909 Broadway, which has only been in business a few months, has already developed a very profitable trade with this line. The new Pathé records have been very popular with this store's clientele and according to the plans of the Pathé Frères Co. Pathé dealers will be given every possible co-operation and service during the next few months.

## Harlem Trade Very Satisfactory

In the 125th street district July business was unusually active and from a talking machine standpoint this street is gradually becoming one of the city's important retail centers.

The retail Victor department of I. Davega, Jr., will shortly be improved by the addition of several new demonstration booths, which will be ready in ample time to handle the fall trade. Herman Lowenstein, manager of this department, is most enthusiastic in his predictions for the future, especially as his company's summer business has been far ahead of expectations.

The Grafonola Shop, 143 West 125th street, handling the Columbia line exclusively, closed a very satisfactory July trade. Courtland Shaw, manager of this store, recently visited Boston, and while there gathered some new ideas in connection with the handling of his repair department, which has greatly enhanced the efficiency of this important department.

Winterroth & Co., the well-known piano house, recently arranged to handle the complete Pathé line in the company's Harlem store, at 14 West 125th street. J. E. Winterroth, manager of this store is well pleased with the results already achieved in his Pathé department, and expects to close a splendid fall trade.

Harry W. Acton, manager of the Victrola and Grafonola departments at the Kranich & Bach store, 16 West 125th street, states that business for the month of July was far ahead of expectations.

J. A. Kraus, manager of the Triton Phonograph Corp., 41 Union Square, New York, is recovering from a serious operation.

## REGISTRATION OF TUNGS-TONE

Some Interesting Data Leading to the Acceptability of This Word by the United States Patent Office Filed by the Victor Co.

In a recent issue of Printers' Ink, an interesting article appeared relative to the success of the Victor Talking Machine Co. in securing registration for the name "Tungs-tone" from the Patent Office, at Washington, D. C. As this article points out, below, the Victor Co. was obliged to overcome numerous obstacles before it was finally successful in its claims.

"Wonder that the Victor Talking Machine Co. was able to 'get by' at the Patent Office with 'Tungs-tone,' its latest trade-mark, has been freely expressed in advertising circles. As a matter of fact, the word was rejected by the United States Examiner of Trade-Marks at Washington until he was instructed from the office of the United States Commissioner of Patents to rule differently. The decision, on appeal, makes it appear that 'Tungs-tone' was never warrantably in danger at the Patent Office, and this opinion from headquarters may be interesting to advertisers in general as shedding additional light upon the acceptability of the suggestive word—most sought of all types of trade-marks.

"'Tungs-tone' was proffered for registration by the Victor Co. as a mark for its new-style talking machine needles or styli, and since the needle points are admittedly made of tungsten the trade-mark examiner promptly made a ruling that 'Tungs-tone' is too near tungsten. Of course the examiner had to take cognizance of the fact that the word as used by the Victor, is divided into two parts, and that in pronouncing it the average retail dealer in talking machines is prone to place the emphasis on the last syllable in pursuance of the Victor advertising policy that always plays up the 'tone' of its products. However, that aspect of the case did not disconcert the head of the trade-mark division, for he held that even though the word be divided it fell under the ruling in the case of the Shumate Razor Co., wherein it was decided, some time since, that 'Tungsteel' could not be registered as a trade-mark for razors and pocket knives.

"As a reward of merit for originality, however, the first assistant commissioner gave his sanction to the Victor Co. when it appealed the 'Tungs-tone' case. He has pointed out, in justification of his action, that 'Tungs-tone' is a newly coined word, not in the dictionary, and that therefore no one would need it in describing his needles. In other words, he holds that it leaves open to everybody else all words in-

## REPAIRS

All Makes of Talking Machines  
Repaired Promptly and Efficiently

**TALKING MACHINE REPAIR  
AND SALES CORPORATION**  
ANDREW H. DODIN, President  
25 East 14th Street New York  
TELEPHONE, STUYVESANT 292

cluding 'tungsten' that would be useful in describing any quality or property appertaining to phonograph needles. \* \* \*

"Counsel for the Victor Talking Machine Co. were able to cite, in pressing their appeal, a number of comparatively late decisions at the Patent Office as indicating the recent leniency of Patent Office practice with respect to suggestive words. That familiarity on the part of an advertiser with the concessions as to trade-marks that have been made to other advertisers may prove a genuine asset is indicated by the final 'Tungs-tone' decision which seemingly gives partial credit for the reversal of the trade-mark examiner to the mustering of precedents.

"Among the current admissions that the Victor instanced to justify the entry of 'Tungs-tone' were the acceptance of 'Porceliron' for enameled ware; 'Benzo-Boreine' for an anti-septic lotion; 'Kromoke' for leather belting; and best of all because in the musical field and embracing 'tone,' the word 'Interpretone' lately allowed for mechanical music-playing instruments. Confronted with this array the first assistant commissioner of patents said with respect to 'Tungs-tone': 'In view of these decisions and the instances showing the trend of the office practice, it is believed that this word should be allowed.'

## TO OPEN OFFICE IN CHICAGO

R. D. Wyckoff, general manager of the Emerson Phonograph Co., New York, announced this week that the company had arranged to open a branch office at 7 East Jackson boulevard, Chicago, Ill., in order to handle its fast growing trade in the Middle West. F. W. Clement has been placed in charge of this branch, which will carry a complete stock of Emerson records and make deliveries to the dealers in that territory.

L. L. McMaster, of Wakefield, Mass., has secured the local agency for the Columbia.

# Hermann Thorens, Ste-Croix

(Switzerland)

## Talking Machine Works

SPECIALTY:

# First-Class Motors

AND ALL ACCESSORIES FOR THE TALKING  
MACHINE INDUSTRY, SUCH AS:

SOUND BOXES, TONE ARMS, Etc.



**TALKING MACHINES FOR HAITI**

**Consular Agent Reports a Good Opening for Inexpensive Machines There**

WASHINGTON, D. C., July 31.—According to special agent Garrard Harris, there is an opening in Haiti for an inexpensive talking machine. He says "It should be as simple and durable as it is possible to make and as near 'fool proof' as ingenuity can devise. Wax records will not do on account of their liability to breakage and also because of climatic conditions. The flat rubber records should be provided and, if possible, should contain a selection on each side.

"If an agency could be established to sell instruments on the instalment plan, the number disposed of would be large. The Haitians, or the vast majority of them, are not able to make purchases involving a considerable outlay at one time, but on a payment down and a certain sum per week will undertake and carry through financial outlays otherwise impossible. They are very fond of music and would undoubtedly welcome the opportunity to purchase talking machines, of which there are very few, indeed, on the island. There would be a limited demand for the more expensive kinds also.

"Records in French would prove most popular. Representatives should be thoroughly familiar with and fluent in the French language to be successful."

**TO HOLD ANNUAL OUTING**

The New York Talking Machine Co., Victor distributor, has made arrangements whereby its employes will hold their annual outing and games on September 9 at Beech Hill Inn, Rye Beach, N. Y. A comprehensive program of athletic events has been prepared for this year's outing with the star attraction in the shape of the annual baseball game between the single and married men. Last year's game was won by the bachelors, but this year's tussle promises to be even more thrilling than the 1915 game. W. L. Garber and R. G. Craig are in charge of all arrangements and a banner attendance is expected.

**LOOK OUT FOR THIEVES**

Sol Lazarus, the well-known Victor and Columbia dealer at 216 East Fifty-ninth street, New York, reported last week the loss of two Columbia and nine Victor sound boxes from his establishment. The thieves have not yet been apprehended, although no effort is being spared to bring them to justice. This thievery of sound boxes has been prevalent in the East the past few months, and there is apparently an organized band concentrating in this field.



**Dealers Appreciate**

the efficiency and good judgment of manufacturers who ship their cabinet machines in

**ATLAS PACKING CASES**

(3-ply veneer—clear spruce cleats)

These cases save freight charges and the contents arrive in perfect condition.

*Write for complete information*

**NELSON & HALL CO.**  
MONTGOMERY CENTER VERMONT

**D. D. O'NEILL BECOMES MANAGER**

Of the Talking Machine Department of Gimbel Bros., New York—An Experienced Man

D. D. O'Neill was this week appointed manager of the Victrola department of Gimbel Bros., New York, succeeding George W. Morgan, who had been in charge of this department in connection with the piano, sheet music and musical merchandise sections.

Mr. O'Neill is thoroughly versed in all details of the Victor business and recently conducted his own Victor establishment in Philadelphia, Pa. The Gimbel Victor department is one of the most successful in this city and will offer Mr. O'Neill unlimited opportunities for development and expansion.

F. E. Fitzgerald retains charge of the piano sheet music and musical merchandise departments.

**"ALONG BROADWAY" POPULAR**

The latest Edison publication, "Along Broadway," is growing in popularity with each succeeding issue. It contains interviews with the

great personalities of the opera, notes and comments on various developments along musical lines, and information bearing on the Edison Diamond Disc phonograph. While designed primarily for circulation among owners of Edison machines it has proven so interesting that it is being sought by persons who are not owners of machines, but who wish to keep themselves posted on musical events and progress. The magazine is attractive from a typographical standpoint, and the increasing demand for it shows that it is fulfilling its mission well.

**CASES ON THE CALENDAR**

Judge Mayer, in the United States District Court, called the calendar for the cases to be argued in the court's September and October terms. A number of talking machine manufacturers have actions on this calendar, including the following: Victor Talking Machine Co. vs. Sonora Phonograph Corp. (three actions); Victor Talking Machine Co. vs. Globe Talking Machine Co.; American Graphophone Co. vs. Emerson Phonograph Co.; Gibson vs. Sonora Phonograph Corp.

**Biggest Hits of the Year!**

**Mascot Nos. 1 and 2**

**STYLE No. 1**

Hornless, cabinet style machine, with a good strong motor. All metal parts nickel plated. Height 16 inches, width 8½ inches, depth 9 inches. Plays 5 and 7-inch records. White Enamel, Mahogany, or Walnut Finish. Packed in individual cartons. Wholesale, \$4.

**STYLE No. 2**

This is the only phonograph of its size that plays all sizes and makes of records. It stands 30 inches high, 15½ inches wide, 14½ inches deep. All metal parts are nickel plated. Equipped with a very strong double-spring motor, a 10-inch turntable and Universal Tone Arm. Highly polished cabinet, MAHOGANY finish. Wholesale, \$15.

*Write for complete catalog*

**Mascot Talking Machine Manufacturing Co.**

66 West 37th Street NEW YORK



Mascot No. 2



Mascot No. 1



The new line of Columbia Burl Walnut Grafonolas are practically non-competitive. Have you seen your Distributor regarding these new models?

(Write for "Music Money," a book "full of meat" for those dealers interested in quick and frequent turnover of capital)

Columbia Graphophone Co.  
Woolworth Building, New York

### ENGAGE THE RIALTO ORCHESTRA

This Organization, of Which Hugo Riesenfeld Is Conductor, to Make Records for Emerson Co.

The Emerson Phonograph Co., New York, has completed arrangements whereby the Rialto Orchestra, conducted by Hugo Riesen-



Hugo Riesenfeld

feld, will make a series of records for the Emerson disc library. This orchestra, consisting of thirty-five selected musicians, has proven a big attraction at the Rialto Theatre, Forty-second street and Broadway, New York.

Mr. Riesenfeld is prominent in musical circles both here and abroad, having been concert

master at the Imperial Opera House in Vienna, and in recent years being associated with the Manhattan Opera House and the Century Opera House in New York. The Rialto Orchestra has already recorded several selections for the Emerson library which will be ready for the Emerson trade in the very near future.

### TALKING MACHINE MEN, INC., MEET

Discussion of Misleading Advertising a Feature of Monthly Meeting

The monthly meeting of the Talking Machine Men, Inc., was held July 19 at Keen's Chop House, 70 West Thirty-sixth street, New York, and was well attended, in spite of the fact that a large number of members were on vacation.

A luncheon was served at 1 o'clock and the business session immediately followed. In the absence of President Hunt, Vice-President J. T. Coughlin presided. He opened with a few brief remarks and stated that owing to the hot weather business would be transacted as rapidly as possible.

Chairman Shepard, of the committee on credentials, presented several applications for membership, which were voted on and accepted. This committee also reported that it was succeeding in getting publicity for the organization that would be of great benefit in enlarging its membership. Mr. Shepard also stated his committee was preparing a card for use in windows and other conspicuous places, showing that the displayer was a member of the Talking Machine Men, Inc.

The association went on record against misleading and detrimental advertising. A resolution was also passed instructing the secretary to prepare letters to be presented to the different manufacturers of records giving them all the information the association possessed in regard to price cutters. After the meeting was officially adjourned, several informal talks took place.

### INSTALL DEMONSTRATION BOOTHS

Prominent Concerns Find Use for the Van Veen "Bed Set" Booths—Numerous Inquiries

A. L. Van Veen, president of A. L. Van Veen & Co., New York, manufacturer of Van Veen "Bed Set" demonstration booths, stated this week that the company had received quite a number of letters of praise from local dealers for whom it had installed booths during the past few weeks. Among these concerns are the following: Kraukauer Bros., Christman Sons, Stultz & Bauer and Savidge & Reed.

Mr. Van Veen also stated that he had received numerous inquiries from dealers throughout the country who are planning to add to their equipment before the fall season starts. Baumann & Co., 162d street and Third avenue, New York, arranged this week for the installation of a complement of Van Veen booths.

### RECEIVER FOR ALBANY CO.

ALBANY, N. Y., July 31.—The Albany Diamond Disc Co., retail distributors of talking machines, was placed in the hands of a receiver last week, Nathan D. Griffen being appointed as the same. The petition in bankruptcy which was filed shows liabilities of \$44,000 and assets of \$35,000. The receiver has been given permission to continue the business of the concern, under a bond of \$20,000. The creditors of the concern are being represented by H. D. Wright, of Gloversville, N. Y.

### MAKING DETERLING MACHINES

MUNCIE, IND., August 5.—The Deterling Talking Machine is being built by the Deterling Music Co. in the factory of the Bell Bros. Piano Co., space having been rented in the factory for that purpose. Contrary to a report recently published, there is no connection between the Deterling concern and the Bell Bros. Co.

## John M. Dean Corporation

Putnam, Conn.

Manufacturers of

# Talking Machine NEEDLES

Dean Service covers every essential need in talking machine needles. Needles furnished in bulk or in special packages. Quality needles only.

# THE TRADE IN THE SOUTH

## TRADE BOOMING IN THE SOUTH

**Crop Conditions Excellent in Most States, Though Floods Have Done Some Damage—Increasing Demand for Machines and Records**

Talking machine business in the South continues to show a very favorable trend despite the fact the summer season usually brings a cessation of activities in almost every line of business. Aside from the growing popularity of the talking machine, the enhanced prosperity of the South has greatly increased the number of people to whom a talking machine is now a necessity rather than a mere luxury. The agricultural and industrial conditions in the South as a whole are very promising.

Crops are in good shape in Virginia and most of the wheat and oats have been cut and have shown a bountiful yield. Corn is making a fine showing, the same condition prevailing in West Virginia, where the setback to the corn crop which occurred in the early part of the season has been entirely overcome. In Kentucky the outlook is very bright. The hay crop was excellent and the corn and tobacco prospects are very rosy. The yield of wheat is not as high as was expected but the quality is excellent. Unusually good prices are being offered for live stock.

The recent weeks have brought a great deal of rain in the South, which, on the whole, has been beneficial. In Tennessee, however, there has been little rain, and while the cotton crop is good, the corn crop would be greatly benefited by more rain. Prospects of a good crop of cotton in Texas are excellent. There have been good rains in the southern section of the State although the Pan-Handle complains of some drought, which is not serious, however. Crops are better in Louisiana than for several years.

Cotton is in full bloom and the corn crop is excellent and is practically made.

The erection of a large packing house at Statesboro, Ga., which is in the center of the finest agricultural section, and for which a contract has recently been completed, will greatly stimulate the production of live stock. Heavy rains in the southeast section have reduced crop prospects somewhat. The corn crop, especially, will suffer, and the cotton crop will show a decrease, but conditions on the whole are fairly good. The situation in Alabama is not as favorable as might be wished. The heavy rains and floods did considerable damage, although the crops on the highlands are excellent. Increasing indications of diversified farming are seen on every hand, which will enhance the future prosperity of the State.

Unusually good crops are reported from the northern section of Mississippi. In other sections of the State the outlook is not so good, as thousands of acres of corn and cotton have been ruined by the water overflow.

Continued prosperity is shown in the manufacturing centers throughout the entire South and unemployment has been greatly diminished. The people generally are making more money than they have for some years past, and they are evincing their love for music, which is characteristic of them, by investing a fair proportion of their earnings in musical instruments. Talking machine distributors in every section of the country report a demand which has actually resulted in a shortage of goods. There is an excellent call for the better class of records and the average price of talking machines sold is much higher than formerly, all of which indicates prosperous conditions in the talking machine trade, and bright prospects for a continuance of the same in the future.

## ORIGINAL ADVERTISING WINS

**How the Victor Department of the Rhodes-Mahoney Co. Has Increased Its Business**

CHATTANOOGA, TENN., August 1.—The Victor talking machine department of the Rhodes-Mahoney Furniture Co., of this city, which is under the capable management of H. G. Ray, is one of the most enterprising in the South. Advertising in the local papers is a favorite means of concentrating attention on the establishment, and a recent ad, which called attention to the resources of this department, its offer of one year's service on any Victrola purchased, with an expert mechanic at the buyer's service, has been no small factor in the growth of the business.

A recent advertisement which contained pictures of the various styles of Victrolas and portraits of Manager Ray, Mrs. L. R. House, in charge of the record department, and J. B. Wilbanks, of the repair department, has come in for considerable praise. In this connection Mr. Ray remarked: "This campaign of advertising has more than doubled our business, and has caused considerable comment because of its originality." It is worth noting that concerns that do advertise in this original way win out.

## TRADE CONDITIONS IN SAVANNAH

SAVANNAH, GA., August 1.—Trade for July and August in this locality is usually rather quiet while the cotton is in the making, for most of our people are either at the seashore or in the mountains. While there has been considerable damage to some of the crops in the Southwest and Northern Georgia by recent floods, yet this immediate vicinity has not been very seriously

(Continued on page 90)

**"A Winner of Trade—Where-ever Displayed"**

**JUST OUT!**

Retails for  
**\$6.00**

## Corley Victrola Carrying Case

Sells like "hot cakes"—every owner of a Victrola IV will want one! Will increase your sales of machines. Pays the dealer a good profit! As handy to carry as a suit case—as strong and durable as a trunk.

### Fills a Long-Felt Want!

Extra well made from three-ply veneer, covered with hard fibre, including bottom. Inside measurements, 17½" long, 13¼" wide, 11" deep. Fibre bound, heavy steel braced trimmings, excelsior lock; strap hinges, bolts, cloth lined. Fitted with blocks to hold Victrola in place when traveling.



**Be First**

to reap the profits from this big seller. Sample case \$5.00. In lots of 6 or more, \$4.50. Immediate shipment made.

**The Corley Company**

The Victor House of Dixieland—Distributors

213 East Broad Street, Richmond, Va.

**VICTOR**  
Service is Supreme  
in the South!



The Columbia selling methods and effective advertising are bringing the line more and more into public notice every day—and the dealers not yet carrying the line are feeling this, as well as those who do. We have the clearest kind of evidence of that fact before us all the while.

(Write for "Music Money," a book "full of meat" for those dealers interested in quick and frequent turnover of capital.)

Columbia Graphophone Co.  
Woolworth Building, New York

### THE TRADE IN THE SOUTH

(Continued from page 89)

affected. The local dealers handling the leading talking machine lines are looking forward to a very fine fall business. The trade outlook is excellent in every respect and the dealers are well prepared.

### CARRYING TRUNKS FOR VICTROLAS

Corley Co. Announces New Convenience for the Owners of Smaller Types of Machines

The problem of the Victrola owner who desires to carry his machine to camp or country, and who has been faced with the alternative of having the instrument securely boxed or take chances on having it damaged, has been solved by the Corley Co., of Richmond, Va., which has placed on the market its new trunks for Victrolas VI, VIII and IX. The trunks are made of exact size to fit the machines, are constructed of three-ply veneer and covered with hard fibre, have metal corners and substantial locks and are fitted to carry the Victrolas securely without packing. The trunks should appeal not only to the talking machine owners but also to the salesmen who have occasion to carry sample machines on their travels. Straps are provided so that the trunk may be carried as a suit case and it is also strong enough to permit of its being checked as ordinary baggage. It should prove to be an all-year-round trade feature.

### HOW THE GRAFONOLA AIDED RECRUITING IN NEW ORLEANS

NEW ORLEANS, LA., August 6.—The B. Grunewald Co., of this city, took advantage of a timely opportunity recently when the National Guard

the recruiting by means of a Grafonola. The power of music and particularly the power of the Columbia list of double-disc patriotic records

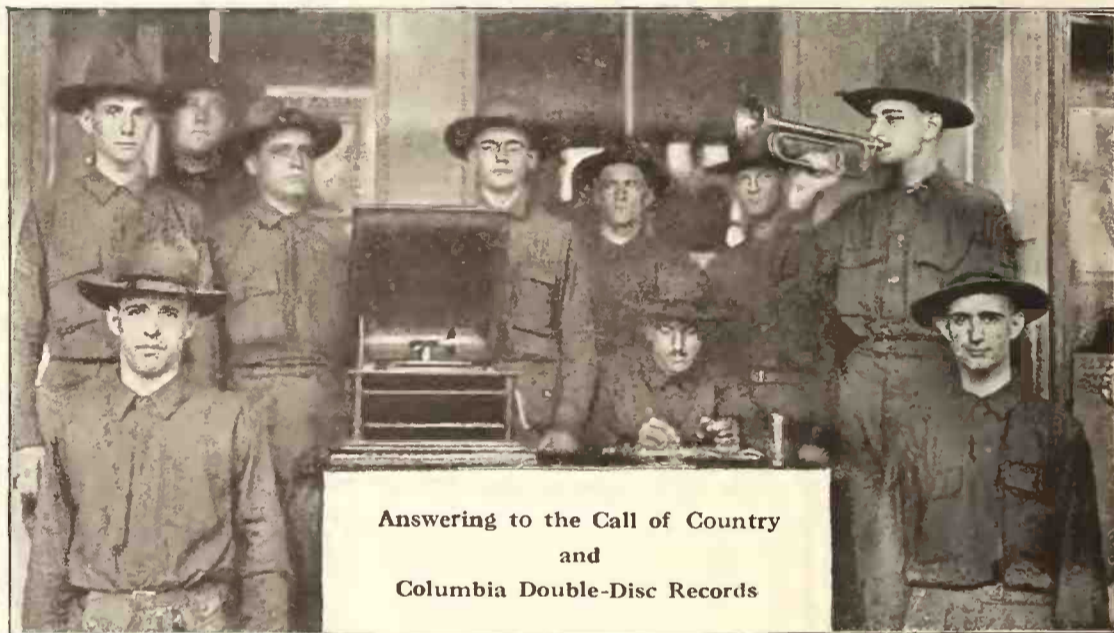

Answering to the Call of Country  
and  
Columbia Double-Disc Records

of this city prepared to mobilize in response to instructions from the Government officials, and it was found that artillery companies A, B and C lacked a full complement of men.

A recruiting office was opened and at this point the B. Grunewald Co. suggested aiding

resulted in the three companies recruiting to desired strength in a few days.

### LARGER QUARTERS IN ATLANTA

The Columbia Graphophone Co., of Atlanta, Ga., has leased the entire third floor of the Rosser & Porter Building at 63 North Pryor street for a term of three years. The company formerly occupied a portion of the third floor, but their increasing business made additional space necessary. Their new lease gives them 10,000 feet of floor space.

### PRIZE ESSAY CONTEST ON VICTROLA

MACON, GA., August 5.—The Oberry-Williams Co., Victor dealers, recently conducted a prize contest for the best essay on the subject, "The Victrola in the Home." Many really good essays were received, the prize, a \$50 Victrola, being awarded to Mrs. Louis Carter, the committee of award being composed of three ladies interested in literary work.

### VICTOR ADS ON WRAPPING PAPER

ARLINGTON, TEX., August 7.—Coulter & Son, Victor dealers in this city, are advertising Victrolas and Victor records in a rather unique manner by having their Victor advertisements appear on the wrapping paper on each package that leaves their store. By changing these advertisements frequently the company has been able to carry into the homes of all visitors to its store a very effective Victor message.

The Lenoir Phonograph Shop was recently opened on West Main street, Lenoir, N. C.; a recital hall being one of the features of the new store, which will feature the Edison Diamond Disc phonographs and records.

# BUFFALO

## RAILROAD — EXPRESS — STEAMSHIP

Look at the list of railroads running out of Buffalo: New York Central, West Shore, Lake Shore, Nickel Plate, Wabash, Erie, Pennsylvania, Lackawanna, Grand Trunk, Michigan Central, Lehigh, B. R. & P. and B. & S.

Four express companies will give you a complete service: American, National, Adams & Wells-Fargo.

Boat lines touch a great many cities, on the Lakes, and Andrews' Service can catch any boat on fifteen minutes' notice.

Doesn't it stand to reason that we mean what we say when we remark: Andrews' Victor Service is *Fast* and *Complete*.

W. D. Andrews, Buffalo, N. Y.

# ANDREWS

# FROM OUR EUROPEAN HEADQUARTERS

2 GRESHAM BUILDING, BASINGHALL STREET E. C., LONDON, W. LIONEL STURDY, MANAGER.

General Feeling of Financial Insecurity Has Effect on British Talking Machine Trade—Scarcity of Competent Workmen a Factor—Increase in Imports Reported—Planning for Active Trade Campaigns After the War—New Russian Records Listed by British Houses—What the Newest Record Lists Contain—Court Asked to Decide on Standard Record—Enterprise Shown by Certain Concerns in Face of Adverse Conditions—Records to Instruct in Wireless Operation—More German Firms Ordered to Liquidate—Shortage of Packing Boards Announced

LONDON, E. C., ENGLAND, July 26.—In the gramophone and musical instrument domain general trade conditions are not overbright at the moment. Except perhaps in particular centers, sales have fallen off considerably all over the country, mainly we should imagine in consequence of a widespread feeling of insecurity as to the effect of calling-up wage earners and business men generally for military service. These days money is not so freely spent on things-one-can-do-without, and there is now a more general desire to invest in war loans, or otherwise earmark surplus earnings for deposit in the bank. All men up to the age of forty-one not yet in khaki or exempt come under the military service acts, and this gigantic domestic upheaval obviously is going to turn things inside out. Dealers therefore fear to add to their stocks or otherwise tie up capital. The trade has reached a kind of ragtime stage when orders are placed piecemeal as conditions demand, though in bulk, quite a fair business is being done. Of the prospects for the season, I feel sanguine that trade will not be unsatisfactory,

conditions and difficulties considered. Once we reach a level and know, or rather be, in a better position to estimate possibilities and probabilities at their true value, definite plans of campaign and expenditure can be more safely embarked upon. As it is, one is shy of taking action, though necessity has compelled in certain quarters commitment to confirmation of contracts. Despite little individual forebodings, which happily find only secret expression, there is, broadly speaking, an unshaken confidence in the industrial and political future. The war has reached a stage when reasonable optimism is more than ever justified. But in the present stage of the conflict it were foolish to indulge in estimates of an early peace, and we have therefore schooled ourselves to look both ways determined to make the best of things as they are, proceed cautiously, and be ready for anything that may eventuate.

#### A Glance at Trade Conditions

A glance at the inner workings of the gramophone trade in relation to official prohibitions, etc., may be of interest. The question which takes precedence of all others is that affecting the right of the trade to import certain necessary parts and accessories. Although the position in this respect is still a little uncertain it is becoming clearer each day, and is by now pretty well known that the Board of Trade has conceded the music trade permission to import under license a specified portion of its annual imports. France and Switzerland, I understand, may be authorized to sell us goods up to about 50 per cent. of the total value we imported during twelve months prior the prohibition order. These goods represent articles required by the whole music industry, as for instance, piano

actions, and certain metal parts; gramophone motors, tone arms, sound boxes, horns, etc.

In regard to imports from America, the position is somewhat better than was at first thought possible. Official restriction, which for a long time held just against all argument, has at last been removed to the extent of permitting the importation of metal parts up to 140 tons per month. Being perhaps the freest and most flexible center of the world's metal markets at the present period, American foundries are in the best position to look after our small musical requirements promptly. The weight allowed is a mere fleabite, yet so urgent are our requirements on shipping capacity—every available foot of space being required for the transport of other or more necessary merchandise—that it was only after very considerable difficulty and argument, our officials were moved to make the concession of this small amount of tonnage. Small, yes!—but withal vital to the existence of the music trade industry, vital out of all proportion to the other interests at stake? This 140 tons will not go far. It has to be spread over the pianoforte, player, organ, gramophone, and every other section of the trade. Still, we are grateful under the circumstances, because it will enable us to keep things going pending a return to the good old times, of now, it seems, so long ago!

#### Planning Post Bellum Campaigns

So far as is possible under the present difficult conditions it is pleasing to note that quite a number of British gramophone firms have prepared a plan of campaign to go into effect as soon as the war is over. These plans in the main are, by the exigencies of the situation,

(Continued on page 92)



"His Master's Voice"

Copyright

This intensely human picture stands for all that is best in music

—it is the "His Master's Voice" trade-mark, and it brings to you, no matter where you are, the very best music of every kind, sung and played by the world's greatest artists—the greatest singers, pianists, violinists, orchestras and bands—all enshrined in the unequalled "His Master's Voice" records

## 'His Master's Voice'

—the trade-mark that is recognized throughout the world as the

## HALL-MARK OF QUALITY

#### Branches

**DENMARK:** Skandinavisk Grammophon-Akti-selskab, Frihavnen, Copenhagen.

**FRANCE:** Cie. Française du Gramophone, 115 Boulevard Richard Lenoir, Place de la République, Paris.

**SPAIN:** Compañía del Gramófono, 56-58 Balmes, Barcelona.

**SWEDEN:** Skandinaviska Grammophon-Aktiebolaget, Drottning Gatan No. 47, Stockholm.

**RUSSIA:** The Gramophone Co., Ltd., 45, Nevsky Prospect, Petrograd (Petersburg); No. 1 Solyanka, Solyanoi Dvor, Moscow; 9, Golovinsky Prospect, Tiflis; Nowy-Swiat 30, Warsaw; 33, Alexandrowskaya Ulitsa, Riga; 11 Michailovskaya Ulitsa, Baku.

**INDIA:** The Gramophone Co., Ltd., 139, Bal-laghatta Road, Calcutta; 7, Bell Lane, Fort, Bombay.

#### Great Britain:

## The Gramophone Company, Ltd.

HAYES - MIDDLESEX - ENGLAND

#### Agencies

**AUSTRALIA:** S. Hoffnung & Co., Ltd., Sole Concessionaries of The Gramophone Company, Limited, 163, Pitt Street, Sydney.

**NEW ZEALAND:** Gramophontum, Ltd., 118-120 Victoria Street, Wellington.

**SOUTH AFRICA:** Darter & Sons, Post Box 174, Capetown; Mackay Bros., Post Box 251, Johannesburg; Mackay Bros. & McMahon, Post Box 419, Durban; Ivan H. Haarburger, Post Box 105, Bloemfontein; Franz Moeller, Post Box 108, East London; B. J. Ewins & Co., Post Box 88, Queens-town; Handel House, Kimberley; Laurence & Cope, Post Box 132, Buluwayo; The Argus Co., Salisbury.

**EAST AFRICA:** Bayley & Co., Lourenço Marques.

**HOLLAND:** American Import Co., 22a, Amsterd Veerkade, The Hague.

**ITALY:** A. Bossi & Co., Via Orefici 2, Milan.

**EGYPT (Also for the Soudan, Greece and the Ottoman Empire):** K. Fr. Vogel, Post Box 414, Alexandria.



We do not rely on giant advertisements for Sales—We depend on intrinsic Merit alone.

No amount of advertising can increase the value of

## WINNER RECORDS: ("The World's Super-Disc")

They outwear all others.

Only up-to-date songs and selections recorded.

Winners leave the dealer a generous margin of profit.

**THEY SELL ON THEIR MERITS**

Independent LIVE REPRESENTATIVES WANTED—in U. S. and British Colonies  
Write the manufacturers for Trade Terms

### THE WINNER RECORD CO., Ltd.

Willowbrook Grove, Camberwell, London, England

FROM OUR LONDON HEADQUARTERS—(Continued from page 91)

merely on paper, so to speak, yet none the less merit encouragement. As time passes they will mature and take practical shape. In examining every detail of what is likely to prove a somewhat complex situation when peace shall again reign, we are on the right track to preserve and develop our trade interests to the exclusion of after war enemy propaganda. All that can be urged at the moment is to perfect our system and organize not for defensive purposes, but for an immediate trade-war offensive the moment conditions permit. This is what we are doing, and when expedient so to do I shall advise World readers, especially its huge army of Colonial traders, just what exactly they may expect from this market.

One concrete instance of British enterprise that may now be mentioned is furnished by the house of J. E. Hough, Ltd., Glengall road, Peckham, London. Suitable plant has already been installed for the manufacture of complete gramophones which will render the firm independent of foreign supplies. The labor and supply difficulties are serious handicaps at the moment, but there is already sufficient evidence that Messrs. Hough will be in a position to meet all afterwar machine requirements. Good luck to them!

#### What is a Standard Record?

A novel point bearing upon the playing size of a record was raised in a recent law action between the Regent Fittings Co. of Old St. London, and Hall Bros., Heath road, Ilford. The latter was sued by the Regent people for 5 guineas, the price of a gramophone supplied. On the day of sale plaintiff demonstrated that the instrument contained a motor that would play eight records, but the next day defendant returned and complained that when he tried it at home, the machine would not play more than four records with one winding. On this

ground defendant repudiated the transaction, hence the action-at-law. The evidence at the first hearing being somewhat conflicting, Judge Graham adjourned the case for production of the instrument. Subsequently this was brought into court, and on the Magistrate's advice, taken into the courtyard for purposes of demonstration. After a thorough test it was found that the motor would run not quite to the limit of five records. These particular records, it appears, were supplied by defendant whose counsel said that plaintiff had brought up a lot of records—all short tunes, and he could not allow a test with those on the ground that they were not "standard" records. Plaintiff interpolated that "defendants' records were of very large size, and it was not a fair test . . . he should take records of an average size (length) which I have with me . . . the motor will play eight." After further argument Judge Graham remarked: "I have nothing about standard records on my notes. It was suggested the plaintiff said it would do eight tunes with one wind: the defendant did not suggest the plaintiff said standard records, and when he got home he tried standard records and they would not work." Defendants' counsel: I took it for granted that it was agreed they must be standard records. Judge: You may have done so, but there is no mention of it here, and the plaintiff says he has actually got eight records which can be played by this motor with one wind; isn't that fair on his part? You have proved that it will not play eight standard records, but there is no evidence that he purchased it with the idea that it would do so. Counsel: You will recognize that this case raises a very important point in the trade as to what a record really is. We bought this gramophone to work 10-inch records, the records recognized in the trade, and it raises a big

question if a man can put you off with anything. Judge Graham: I see nothing in the point. The defendant himself admits he took plaintiff's word it would play eight tunes; no mention was made of standard size, but it is not right to say it will not do eight tunes. There will be a verdict for plaintiff for the amount claimed, with costs.

As far as my experience goes, this is the first instance in law of distinction being made between tunes and records. The attempt to raise a question on what counsel was pleased to term "standard" records as measured by length of playing time, is to say the least, ingenious. Plaintiff having demonstrated that his machine would play eight records, there being no guarantee as to the length of each record, only one judgment was possible, in this particular instance. At the same time one cannot help giving expression to the opinion that the contention of defendant's counsel, from a common sense point of view, was quite good. Apart from the case in question, one must agree that in general the claims made as to the playing strength of gramophone motors are often misleading. If these claims are to be based on the number of records a motor will play, it is scarcely fair to determine it by the shortest record that can be found, any more than by the longest. An average should be and could be struck, but I am of the opinion that it would be far more honest to describe this or that machine as containing a motor that will play for so many minutes. By so doing any question of alleged misrepresentation would be entirely eliminated. Towards this desirable end, the law action under review will materially assist.

Grammavox Record for Oversea Buyers  
Far removed from the district known as Phonoland, the Sound Recording Co., Ltd.,

## Mr. DEALER: You Will Be SHORT OF RECORDS This Season!



You lost business last season through the demand exceeding the supply. Don't let it happen again.

Get into touch with us right away, and make sure of your stock for the busiest Fall trade you've ever had.

Our Records are *better*, our Prices are *better*, and our Deliveries are *surer* than any brand you've ever handled.

All enquiries to:—The Manufacturers

THE INVICTA RECORD CO., LTD., 1 New Inn Yard, London, E. C., England

Cables

FROM OUR LONDON HEADQUARTERS—(Continued from page 92)

with its headquarters on Swallow street, Piccadilly, London, W., seems rather to court a certain seclusion outside the publicity limelight so frequently reflected upon the doings of other gramophone houses. While not wholly so, there is nevertheless a measure of truth in the fact that the company are not at the moment desirous of proclaiming too loudly the active work which they are accomplishing in behalf of gramophone traders abroad. Like most other firms the Gramnavox record people have been seriously affected by the shortage of labor, but arrangements are now happily almost complete whereby this difficulty will soon be but a memory. In conversation with the general manager, M. W. Chapman, we were assured that the company's facilities for prompt recording and dispatch of 5,000 lots and up, will enable them to offer oversea buyers the best service towards the complete ousting of enemy firms and oversea record buyers are therefore invited to commence immediate negotiations for adequate supplies of the all-British Gramnavox records at competitive prices. As an earnest of their enterprise and determination, the Sound Recording Co. has already secured additional premises in Swallow street, and as they aptly put it: "We hope to get more of this street in good time." The Gramnavox record (10-inch double) has behind it many years of good reputation abroad for quality and general value, and in this direction there can be no doubt but that the company is on the high road to achieve further successes.

#### Issue Series of Records in Russian

The existing ties of friendship between Britain and Russia will undoubtedly be further strengthened along commercial lines after the war, and sincere commendation is due to any enterprise that will assist in bridging the wide and difficult gulf between the distinctive habits and general intercourse of each country. To a closer commercial understanding a knowledge of the somewhat intricate Russian language is a first essential. Upon that will arise the commercial edifice which it is hoped to build up. In this grand work it is encouraging to know that "His Master's Voice" will speak with no uncertain voice. The policy of the Gramophone Co., Ltd., has ever been one of high ideals and in musical and educational achievement, it stands unquestionably pre-eminent in its successful endeavors to raise the tone of our industry and place it upon a plane as closely allied to art as, under present methods of production, it may attain. In this regard the company's reputation is endorsed by the issue of a fine series of Russian language records, which will make considerably easier the students' task of learning the accent, grammar, and correct phrasing of this intricate language. The records have been spoken by a Russian master—no less a person than Nevill Forbes, M.A., reader in Russian to Oxford University. The chapters are from the "First Russian Book"

(Forbes) published by the Clarendon Press.

#### False Declaration Brings Fine

For making a false declaration with regard to musical instruments imported to Dittlehampton and London, Messrs. Joseph Wallis & Son, Ltd., London, were recently mulcted in fines amounting to £60.

#### Attractive Winner Records

Oversea records buyers are offered a very attractive line in the "Winner" double disc, which, in point of popularity occupies a prominent place on the British markets at home and abroad. The Winner quality is second to none as judged by artistic and recording standards. A new list of good selling titles is issued each month, and dealers have come to place implicit reliance upon the sales value of these issues. That is the supreme test, and as the "Winner" record output increases each month commensurately with the demand, it may be accepted without question as a sign of strength and vitality. This, of course, reflects good service in that provision is made for every musical taste by the issue of records which have all passed a special examination by trained assistants. Apart from this quality test, the Winner boasts a splendid number of star-bill artists, many exclusive, and whose contributions are chosen from the very latest of London's musical programs. A typical example is the current Winner list, and dealers are well advised to obtain it, together with a complete Winner record catalog and trading terms. The company's address will be found in their announcement elsewhere in this section.

#### Variety in Zonophone Records

The essence of Zonophone record issues is "variety," to which also one might add "topicality," for centered in the company's August supplement is about the most comprehensive choice alike welcome to dealer and public. It includes a "special!" What that means the Zonophone public will readily recognize. Many and varied are the songs for Tommy and Jack, but none for the tireless munition workers—until now. This Zono special, as may be guessed, is the one that fills the bill, and fills it very effectively, too! Aptly named "The Munition Workers' Song—an inspiration by, we are glad to note a young British musician, Miss Kathleen Bruckshaw—it portrays in vivid words that will evoke the admiration of all who hear them, a fine tribute to the men "behind" whose lot it is to undergo the stress and strain of continuous weeks and months of hard work at the bench, lathe, or other machine, in support of our gallant army and navy. That pre-eminent artist, Robert Radford (bass) has exclusively recorded this magnificent song for the British Zonophone Co. On the reverse is recorded "The Victor March," by the Black Diamond Band, and altogether nothing is wanting to make the record the success which it undoubtedly merits.

The Zono August list is otherwise well collated in up-to-date numbers, talent and quality!

#### Bid for Suffrage Patronage

Among recent record programs, we notice that the Gramnavox Co. make a bold bid for the suffrages of keen buyers. It may be noted here that special attention is given to oversea trade requirements, details of which are set forth in the company's announcement elsewhere in this section. A fine array of popular selling titles, numbering well over 2,000 and covering every phase of music both vocal and instrumental, is available in big or small parcels at keen prices. Covering a host of standard songs, orchestral, band, and solo-instrumental "hits," the repertory is withal up-to-date, as witness, for example, the production of London's very latest musical delight—"Razzle Dazzle" within seven days of its stage appearance. This Revue is a remarkable success, and the Sound Recording Co. have been called upon to press heavily to insure that no order may go unfulfilled or delayed.

A find profit-making line is offered and publicity matter, lists and terms of trading can be obtained from the Sound Recording Co., Ltd., Swallow street, Piccadilly, London, W.

#### Interested in Canadian Suit

Great interest is being taken by British record manufacturers in the action of the Berliner Gramophone Co., Montreal, to restrain the Winnipeg Piano Co. from offering for sale the Coliseum records, which are made in London. The matter being sub judice, comment for the present is precluded. But we may say that in London trade circles there is a general desire to have this and other patents affecting the sale of British records in a British Dominion, cleared up once and for all.

#### Diminishing Supply of Workers

With most of their "eligibles" either in the army or about to be called up, British firms find it no sinecure to keep things going on the depleted staff at their disposal, and as may be surmised an unusual strain is thereby imposed upon those at the helm to whose lot falls the arduous duty of maintaining an adequate service. It is no wonder, therefore, that under such conditions prevalent over an all too long period nature at last rebels. A case in point is that of Frank Samuel, of the well-known musical instrument house of Barnett Samuel & Sons, Ltd., this city. For many months past Frank has been doing the work of two or three ordinary men, with the inevitable result. Upon medical advice he has been forced to take a prolonged rest, and at the moment of writing is in America. From cablegrams received by Nelson Samuel, I learn that he has much benefited by the sea voyage, and is rapidly regaining his normal good health. Mr. Samuel is expected home early in August, if not before, when we shall hope to find him completely restored.

(Continued on page 94)

## THE EDISON-BELL VELVET-FACE (VF) RECORD

DOUBLE-SIDED—NEEDLE-CUT—10 inch and 12 inch  
IS THE SUPREME EFFORT OF GRAMOPHONIC ART

10 inch  
2/6

12 inch  
4/—

There are no faulty VF's, as Every Record has to pass a crucial test before it is released for sale. The production is of the highest quality. The Titles and Subjects recorded are by the most prominent artists in the Gramophone world.

If your jobber doesn't stock them, try our Direct Service. It will pay you both for quality and price. For full particulars, Wholesale and Retail, apply to



J. E. HOUGH, Ltd., Edison Bell Works, Glengall Rd., Peckham, London, England

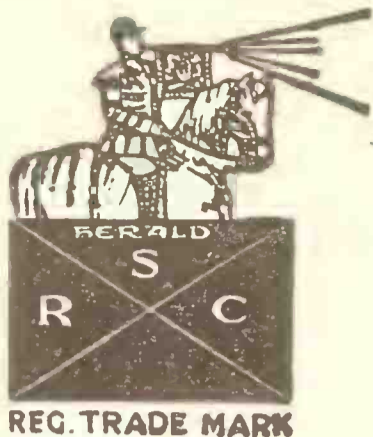

# Gramophone Records

## Special Points for Overseas Keen Houses

"A British Firm of Repute"

"Offers Close Quotations"

"5000 'Five Thousand'  
Lots and Up"

Address: **EXPORT MANAGER**  
**SOUND RECORDING COMPANY, LIMITED**  
Swallow Street, Piccadilly, London, England  
CABLES:—**"GRAMMAVOX, LONDON"**

### POINTS

- Repertoire, nearly 2000 Titles.
- Hundreds of Superb Bands and Orchestras.
- Lightning Shipments under Export Licenses.
- Packing by Experts.
- Special Labels if Required.
- Real Rock Quotations.
- F. O. B. London or Port of Entry.
- The Finest 10 inch Needle Cut in the Market.

FROM OUR LONDON HEADQUARTERS—(Continued from page 93)

#### Need Not Pay Over Enemy Debts

As British traders are unable to obtain payment of debts due to them by enemies, the president of the Board of Trade announces that they will not be compelled to diminish capital by paying to the public trustee moneys owing to enemy firms. Verb sap!

#### Music of New Revues on "H. M. V." Records

An attractive window poster from the Gramophone Co. reminds us that all the best and latest Revues and musical comedies may be obtained on "H. M. V." records. A few are: "The Bing Boys," "Follow the Crowd," "Bric-a-Brac," "Joyland," "Watch Your Step," "Tina," "Betty," "Pell Mell," "To-Night's the Night," and last but not least, "Razzle-Dazzle," and "Half-Past Eight." The services of the original artists have been secured for many of these fine records!

#### German Firms Ordered Wound Up

The Board of Trade has made orders for the following German firms to be wound up: Reifurt & Co., pianoforte dealers, 30 City road, London; Kastner & Co., Ltd., dealers in player-pianos, 191 Regent street, London, W.

In the case of Auguer, Ltd., music publishers, a reference was made in Parliament to the transference of shares from a German to certain British nominees. It was, however, officially stated that payment for the shares transferred was made by promissory notes payable six months after the war. The advisory committee reported that they were unable to say that the transaction was only colorable, but "Steps were now being taken to transfer the (other—ed.) shares still held by German subjects to British subjects, and to place the company under British control."

#### Wireless Instructions on Records

Yet another field of practical endeavor is being cultivated by means of gramophone records. Made by the Gramophone Co., Ltd.,

the Wireless Press is now in possession of instruction records for radio-telegraphic students who are thereby enabled to perfect their knowledge of "receiving," and enter upon earlier examinations with better chances of success than under the old system of teaching. The records are usable on all needle-disc instruments and may be purchased from the Wireless Press, Ltd., Marconi House, London, W. C.

#### Shortage of Packing Boards

Owing to the great shortage of millboard,

#### HAS HOUSEFUL OF MUSIC

How E. E. Thompson Pipes Talking Machine Music Through His Dwelling

The problem of distributing music throughout an entire house has been solved by E. E. Thompson, of Brazil, Ind., who recently piped talking machine music through his house from a central plant in the basement. By simply touching an electric button on the wall music of melodious tones issues from the cold air duct and the hot air registers in the floors. Every room having a register is provided with music. Even the cook can peel potatoes to the tune of a lively one-step or broil a steak to an aria from grand opera.

The invention of Mr. Thompson is based on the principle of the talking machine. On a large circular table in the basement, supported by gas pipe legs, are a series of ten iron discs. Each of the discs supports a standard phonograph record. All of the discs are kept in motion by a long sewing machine belt, which is propelled by a small electric motor attached to the under side of the table. In the center of the table is a big plaster of paris horn pointing downward like a morning glory. At the base of the horn is a tube which, in turn, conveys the music from the needle and sounds through the horn. Down the center of the tube

the Gramophone Co., Ltd., ask their dealers to use every endeavor to ease the situation by making up individual orders to not less than eight records. Each order for one or two records claims a cardboard box made to hold eight or ten records. The request calls for immediate action on the part of dealers, as otherwise the company might be compelled to charge for the box where an order is for less than eight records, in order to keep overhead costs as low as possible.

is a tiny shaft which terminates in a little cork roller. This rolls around on the wavy surface of the top of a wooden rim around the edge of the table.

The needle is allowed to descend to the discs at points where it drops into the outside grooves of the records by depressions cut in the rim. After a selection is played the cork roller reaches the raise on the far side of the depression in the outer rim, climbs up, lifts the needle from the record and carefully places it on the next record. Thus the needle moves from record to record until the whole ten records are played and starts all over again, running as long as the motor is kept going, and supplying music at any hour of the day or night.

### J. Stead & Co., Ltd.

Manor Needle Works

SHEFFIELD, ENGLAND

MANUFACTURERS OF

Talking Machine

Main Springs

Best Prices—Best Quality  
Inquiries Solicited

# EBONITIS LIMITED

MANUFACTURERS OF PLASTIC MATERIAL

*Manufactureros de materias primas*

FOR  
para

## GRAMOPHONE RECORDS

*los discos de Gramophone*

QUOTATIONS GIVEN. ADDRESS

*Se envian precios. Direccion*

**EBONITIS LIMITED, Willowbrook Grove, Peckham, London, S. E.**  
ENGLAND



FEATURING THE EDISON PHONOGRAPH IN HAVANA, CUBA

The group of pictures herewith shows three views of the establishment the of Harris Bros. Co., Havana, recently appointed distributor of

unique window display. The large white disc had circular lines drawn on the face to indicate the grooves of a record. This disc was kept re-

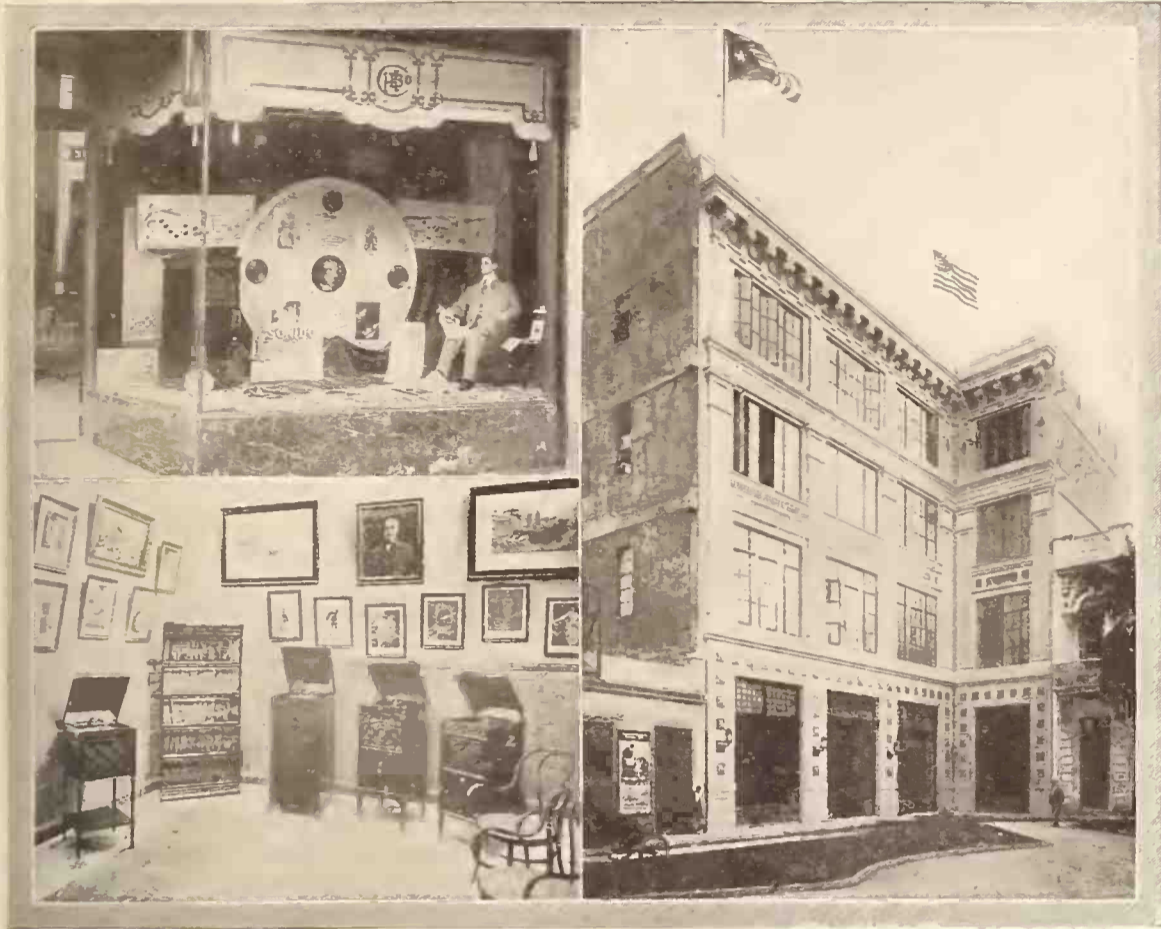

Window Display, Demonstration Room and Exterior of the Harris Bros. Co.

Edison phonographs and records in Cuba. The picture to the right shows the exterior of the Harris Bros. Co. building, which is considered one of the most attractive in the business section of Havana. The upper left illustration shows an

unique window display. The large white disc had circular lines drawn on the face to indicate the grooves of a record. This disc was kept re-

G. W. LYLE ORGANIZING STAFF

George W. Lyle, who recently joined the forces of the Domestic Talking Machine Corp., Philadelphia, Pa., as sales agent, with headquarters in New York, has opened offices in the Trinity Building, 111 Broadway, and is now organizing a capable sales staff which will cooperate with the Domestic dealers along practical lines.

VISITORS AT PATHE OFFICES

Among the visitors last week at the offices of the Pathé Frères Phonograph Co., New York, were W. J. Craig, Toronto, James Malcolm, Kincardine and N. G. Valiquette, Montreal, Can. These gentlemen are the officers of the Pathé Frères Phonograph Co. of Canada, and they visited New York to discuss a number of important matters relative to the manufacturing and distribution of Pathé products in their

country. They were most optimistic in their predictions for the future, stating that there is certain to be a tremendous demand for Pathé phones and Pathé discs throughout the Dominion of Canada.

OPENS COLUMBIA DEPARTMENT

The Allison Furniture Co., of Americus, Ga., has opened a fully-equipped Columbia Grafonola department, with a complete line of the various styles, and a full selection of records.

ESTABLISHING MANY AGENCIES

The Mascot Talking Machine Manufacturing Co., New York, has placed on the market a line of machines ranging in price from \$6 to \$90. It has been establishing a number of agencies in different sections and has been particularly successful with its Styles Nos. 1 and 2, retailing at \$6 and \$25 respectively.

WE ARE PREPARED

To Your Without



Fill Order Delay

Avail Yourself of Our

SPECIAL SAMPLE OFFER

WM. F. NYE

New Bedford, Mass.

THE VALUE OF THE TRADE-MARK

A Display of the Columbia Trade-Mark Secured a Large Record Order from Japan

The Columbia department in the store of Spear & Co., 22 West Thirty-fourth street, New York, filled an order for Columbia records recently which furnished a significant tribute to the popularity of the Columbia "Note the notes" trade-mark.

Dr. Richard Goldschmidt, who had been traveling in Japan, and at the time war was declared, was interned as a prisoner of war, in a recent letter, requested a friend in this country to forward him a representative collection of Columbia records for the entertainment of himself and fellow prisoners. In his letter he particularly asked that the records be of Columbia manufacture, pasting a copy of the Columbia trade-mark on his letter.

The man who had been commissioned to purchase the records happened to pass Spear & Co.'s establishment on West Thirty-fourth street, where he noticed a large "Note the notes" trade-mark in the window, and accordingly decided to buy his records there. With the assistance of Manager Freedman, a splendid collection of records was selected and forwarded to Dr. Goldschmidt.

DIVIDEND FOR BREMNER CREDITORS

Judge Hand recently instructed the trustee of the Bremner Talking Machine Co., of 187 Broadway, to declare a dividend of 12½ per cent. to creditors. Liabilities, as filed at the time of bankruptcy, were \$16,133. After payment of the first dividend there will not be a large amount left over.

ESTABLISHED 1868

EDWARD B. JORDAN & CO., Inc.

127-135 DEGRAW ST.—36-60 TIFFANY PL., BROOKLYN, N. Y.

Talking Machine Cabinet Manufacturers

We made the first talking machine cabinets created in this country, and we have specialized in this particular line ever since.

We will submit special designs of talking machine or record cabinets, or quote you from blue prints or samples. We manufacture to order only.



They all look their money's worth, and they all demonstrate it. They all make their own friends, and keep them. The Columbia line of upright Grafonolas pay as they go.

(Write for "Music Money," a book "full of meat" for those dealers interested in quick and frequent turnover of capital.)

Columbia Graphophone Co.  
Woolworth Building, New York

**NEW HEINEMAN MOTOR ANNOUNCED**

Otto Heineman Phonograph Supply Co. Places Model No. 3 on the Market—Some Exclusive Features Which Will Appeal to the Trade

Otto Heineman, president of the Otto Heineman Phonograph Supply Co., New York, announced this month the latest addition to the company's extensive motor line, consisting of a new model to be known as the Heineman No. 3 motor, 1917 model.

In a chat with The World, Mr. Heineman, referring to this new motor, said: "For several months we conducted numerous experiments and tests in our factory with the idea of developing and perfecting a new motor which could be utilized as a standard motor for floor machines. Our engineers and factory experts spent quite some time on the different phases of the motor problem and finally perfected a motor which we believe has a number of very important new features.

"We have already shipped quite a number of these motors to the leading talking machine concerns throughout the country and I am pleased to say that this new No. 3 motor, 1917 model, is giving perfect satisfaction in every respect. We are now ready to ship this motor in large quantities and the new departments which we recently opened in our factory will enable us to turn out a sufficient number of these No. 3 motors to adequately handle the demands of our trade."

The Heineman No. 3 motor, 1917 model, has

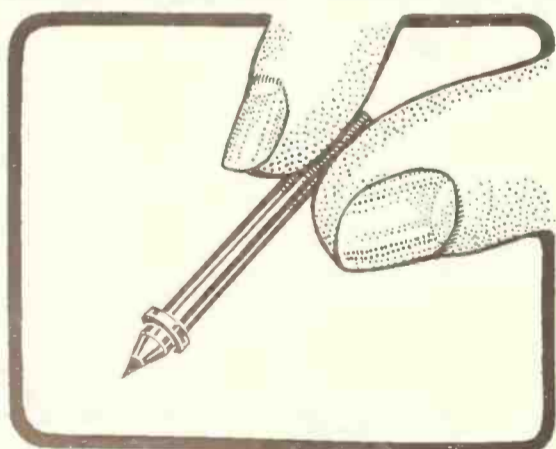

**Sapphire Needles**

Jewel Points

for the reproduction of hill and dale cut records.

Samples

Full Tone - - - 30c each  
Half Tone - - - 35c each

Special prices in dozen, hundred and thousand lots.

**A. F. Meisselbach & Bro.**  
Congress Street NEWARK, N. J.

a screw handle and screw shaft, the turntable shaft is on the end, burnished, hardened and polished. The governor has thrust bearings and the end of the governor shaft is also burnished and polished.

The frame of the Heineman No. 3 motor, 1917

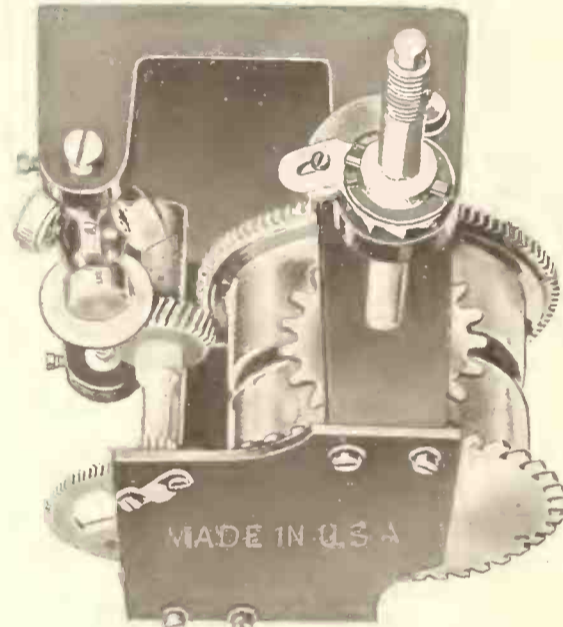

Heineman No. 3 Motor, 1917 Model

model, embodies a number of valuable features which contribute considerably to its mechanical value. When the frame goes on the milling machines great care is taken that there is an exact and precise distance between the winding gear and the ratchet. This aids materially in making the motor absolutely noiseless. Instead of nickel plating the frame the Otto Heineman Co. has arranged to use japanned enamel on all Heineman No. 3 motor frames. This also applies to the spring barrels. The use of japanned enamel not only greatly improves the appearance of the motor, but makes it rust proof.

There are quite a number of other features embodied in the Heineman No. 3 motor, 1917 model, as for example, every screw has lock washers. No effort or expense was spared to make this Heineman No. 3 motor thoroughly representative of Heineman quality, and the reception already accorded this motor indicates that it will achieve a very large measure of success. An agreeable volume of advance orders for this motor have already been received.

**LATEST UDELL LITERATURE**

Just issued by the Udell Works, Indianapolis, Ind., are catalogs Nos. 51 and 52, the former being devoted exclusively to disc record cabinets for Columbia Grafonolas and the latter exclusively to disc record cabinets for Victor Victrolas.

The Udell Works has specialized in record cabinets for many years and the quality of its merchandise is well known by the thousands of merchants of this country.

Tom Griffith, advertising and sales manager, is the prime mover behind the Udell drive, which has resulted in such a big business for the house, and speaking about the new cabinets and catalogs, Mr. Griffith said, "We figure that it is better to have separate catalogs, as where dealers handle Victrolas they want a catalog that does not show anything but Victrolas, and the same is true of the Columbia dealers." Our plant is humming, and we expect this fall and winter to go ahead of all previous records. We not only have cabinets for the Columbia and Victor portable types, but will shortly have folders ready illustrating cabinets for the Pathé, Vocalion, Sonora and Empire machines.

**CRAIG CAMPBELL WITH PATHE**

The Pathé Frères Phonograph Co., New York, closed arrangements recently whereby Craig Campbell, a tenor who has achieved considerable success on the concert and vaudeville stages, will record for the Pathé record library. Mr. Campbell's first records will be announced shortly.

Craig Campbell has made a number of successful tours in different sections of the country, and his rendition of operatic and standard selections has won praise from newspaper and musical critics in the leading cities he visited. His repertoire is extensive and his first recordings will include selections which should meet with a ready sale.

A rather interesting feature of the September list of records issued by the Victor Talking Machine Co. is a double disc pipe organ record, which is claimed is one of unusual excellence. It is difficult to secure a clear reproduction of the pipe organ on a talking machine record.

**"MAGNET" DECALCOMANIE NAMEPLATES**

**FOR TALKING MACHINE CABINETS ETC.**



We can furnish the same or similar style as shown herewith, according to the price scale given below.

	250	500	1000
Gold letters, black edged . . .	\$12	\$15	\$20
Black letters, solid gold background, with fancy border	\$16	\$20	\$25

Samples upon application.

**GEO. A. SMITH & CO., Inc.**  
136 Liberty Street, New York, N. Y.



**WALTER D. MOSES & CO.**  
103 E BROAD STREET  
RICHMOND, VA.

**J. E. STRATFORD**  
AUGUSTA, GA.

The  
**Union Phonograph Supply Co.**

Successors to  
The Union Specialty & Plating Company

**Manufacturers of Talking Machine Supplies**

announce the removal of their general offices and factory  
to their new and modern building

**1100-1108 West Ninth Street**  
Corner of Front Avenue  
**Cleveland, O.**

containing 50,000 square feet of floor space and equipped  
with all the latest modern improvements.

Thanking you for past favors and soliciting your future  
business, we are

Very truly yours,  
**The Union Phonograph Supply Company.**

**HOW MUSIC INCREASES OUTPUT**

Value of the Talking Machine as a Means of  
Enjoying and Stimulating Work Illustrated

The accompanying picture shows the use of a  
talking machine in a glove factory. The em-

This is simply another concrete indication of  
the modern trend of using music as the means  
of relieving nervous strain in the factory. This  
picture first appeared in "System," the well-  
known magazine of business, under the inter-  
esting caption: "Does Music Increase Output?"  
This latter sounds like a proposition in which



Talking Machine Music Stimulates Glove Workers

ployer of these girls says that they can clean  
almost twice as many gloves every working day  
when the phonograph is playing lively music as  
they do on days when it is silent. Conse-  
quently, he believes that investing in a phono-  
graph or two for use in work rooms is well  
worth while.

talking machine dealers ought to offer a pretty  
strong affirmative side, and indeed get some  
new business on the strength of their arguments  
that music does increase output, for the fact  
has been proven on numerous occasions and is  
being generally recognized by employers in  
factories and elsewhere.

**ISSUE IMPOSING CATALOG**

The Lucky 13 Phonograph Co., New York,  
manufacturers of the Cleartone and Lucky Star  
phonographs, has just issued an eighty-two  
page catalog which, in addition to listing the  
various instruments comprising these lines, con-  
tains illustrations and descriptions of every  
part entering into the manufacture of phono-  
graphs. The company carries all conceivable  
parts in stock so that it can supply the trade.

The Weber-Knapp Co., Jamestown, N. Y.,  
suppliers of hardware trimmings for cabinets,  
recently doubled the capacity of its plant.

**UKULELES**

The biggest sellers in the small musical instrument  
business. Why handle inferior machine-made  
American imitations when you can get at similar  
prices the genuine hand-made instruments of

**Jonah Kumulae, Honolulu**

The old, thoroughly seasoned native Hawaiian Koa  
of which they are constructed is greatly superior to  
any other wood in tone quality—Kumulae instru-  
ments have no superior in this respect.  
Send for wholesale price list.

**SHERMAN, CLAY & CO.**  
163 KEARNY ST. SAN FRANCISCO  
Sole Distributors for the United States and Canada

**SUMMER ACTIVITY IN JERSEY CITY**

Leading Stores Across the Hudson Make Most  
Encouraging Reports Regarding Conditions

JERSEY CITY, N. J., August 5.—The talking  
machine dealers of this city have been closing  
an excellent summer business, as the follow-  
ing reports indicate. Record business has kept  
up remarkably well and the shortage of ma-  
chines, as a whole, has slightly abated.

Wissner's warerooms, 134 Newark avenue,  
states that the summer talking machine busi-  
ness has been exceptionally large. Miss Nellie  
Hanly, who is in charge of the talking machine  
department, says her sales have been greatly  
aided by the complete stock of records that her  
department carries. Several new soundproof  
demonstration rooms are soon to be added.  
The Victor, Columbia and the Sonora lines are  
handled by this house.

The Lauter Co.'s store at 149 Newark avenue  
has had a good summer business with the Victor  
line. The demand here for records has also  
been above expectations. The infantile paraly-  
sis scare has kept many home who usually  
spend a part of the summer season at the re-  
sorts, and this has influenced sales of both ma-  
chines and records.

At the Mathushek warerooms, 150 Newark  
avenue, Victrola sales for the summer months  
have been good. C. J. Collins, manager of the  
store, reports the sale recently of a Victrola to  
Chief Monohan, of the Jersey City police force.

Andrew Brunton, whose salesrooms are at  
111 Newark avenue, reports many sales of Edi-  
son Diamond Disc phonographs. He is the ex-  
clusive Edison disc dealer in the shopping dis-  
trict. This store is doing some splendid adver-  
tising in the daily papers and is using original  
ideas.

At the Jacob Doll & Sons' warerooms, con-  
certs on the Pathephone are given daily, and  
are greatly aiding the sales of these machines.  
Samuel D. Metz, manager of the store, states  
that the sale of both machines and records are  
surprisingly large and the outlook for the future  
never was brighter.

**GROUND BROKEN FOR NEW PLANT**

New Factory for Columbia Products Will Cost  
About \$300,000—Is East of Newly Acquired  
Birdsey-Somers Factory

BRIDGEPORT, CONN., July 24.—Ground has been  
broken for the new plant of the American (Co-  
lumbia) Graphophone Co., on Barnum avenue,  
east of the recently acquired Birdsey-Somers  
factory. It is estimated that this new plant will  
cost about \$300,000, and several hundred men  
in the employ of the contracting company are  
rushing the work to an early completion.

The new building is to lie between Bar-  
num avenue and Grant street, along Summer-  
field avenue. It will be of reinforced concrete,  
110 feet wide by 428 feet long, three stories  
high. It will be similar in appearance to the  
former corset factory, but will be of different  
architecture.

Occupation of the Birdsey-Somers plant by  
the Columbia Co. is being taken at the present  
time, the corset machinery and equipment be-  
ing moved out and new machinery being moved  
in. The Columbia Co. has been adding to its  
factory plants in all sections to handle its tre-  
mendously increasing trade, and it is said that  
the end is not yet in sight.

**Hardware for  
Talking Machine Cabinets**

Lid Supports, Tone Rods, Needle Cups,  
Knobs, Continuous Hinges, Etc.

Write for Samples and Prices

**WEBER-KNAPP COMPANY**  
JAMESTOWN, NEW YORK

## LATEST PATENTS RELATING TO TALKING MACHINES AND RECORDS

WASHINGTON, D. C., August 8.—METHOD OF MAKING PHONOGRAPHIC RECORDS.—Hagar H. Byron, Chicago, Ill., assignor by mesne assignment of one-third to A. H. Adams, Ada E. Pickard and J. L. Jackson, same place. Patent No. 1,185,056.

This invention has for its object to provide a new and improved method by which continuous records of any desired length may be made having one or more grooves corresponding with the sound waves to be reproduced; also to provide for making such sound grooves by photography and thus make practicable the simultaneous making of sound records and photographic records on the same medium, such as a flexible film, thereby insuring perfect synchronism.

In the accompanying drawings, Figure 1 is a vertical sectional view showing one form of apparatus that may be conveniently employed for photographing sound waves upon a continuous film and at the same time photographing views thereon; Fig. 2 is an enlarged detail,

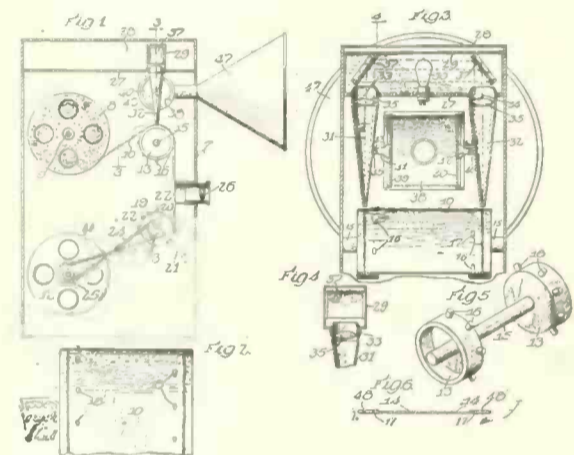

showing the face view of a portion of a combined phonographic and kinetographic record as made by such apparatus; Fig. 3 is an enlarged detail, being a partial vertical cross section on line 3—3 of Fig. 1; Fig. 4 is an enlarged detail, being a partial vertical section on line 4—4 of Fig. 3; Fig. 5 is a perspective view of the guide wheels and shaft, and Fig. 6 is a cross section of the finished record.

SOUND REPRODUCING OR RECORDING MACHINE.—George H. Underhill, Boston, Mass. Patent No. 1,185,149.

This invention consists in improvements in sound reproducing or recording machines, being particularly, though not exclusively, concerned with machines employing a plurality of records which are brought successively into operative relation with the sound recording or reproducing mechanism.

Herein is illustrated one specific embodiment of the invention as applied to a sound reproducing or recording machine employing a feeding mechanism by means of which the records are singly and automatically transferred from a traveling magazine or holder into operative relation with the sound reproducing mechanism of the machine. Subsequently, after reproduction of an individual record, the latter is then automatically withdrawn from its operative position upon the machine and replaced in the holder, which then advances to bring a fresh record adjacent the machine. The new record is then automatically transferred to the machine, the stylus mechanism restored to its initial position, and the operations of the machine, which, during the interval of feeding the records on and off the holder have been suspended, are repeated as described.

In the drawings, Figure 1 is a plan view of the machine; Fig. 2 is a sectional elevation of the record feeding mechanism taken on the line 2—2 in Fig. 3; Fig. 3 is a sectional elevation looking toward the right, and on the line 3—3 in Fig. 2; Fig. 4 is a section on the line 4—4 in Fig. 5 looking toward the right and showing

the feeding carriages; Fig. 5 is a plan view on an enlarged scale of the feeding mechanism with the traveling carrier removed; Fig. 6 is an elevation, partly diagrammatic, showing the

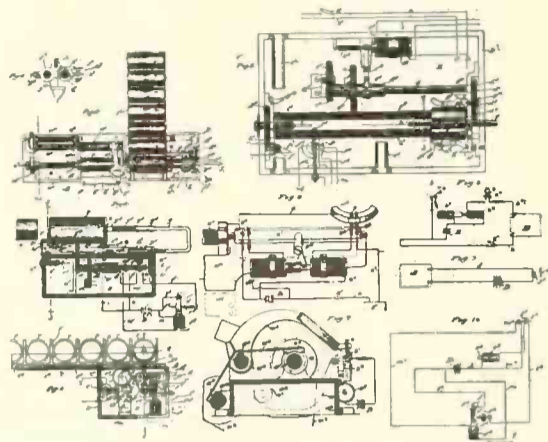

tilting shelf and the control thereof; Fig. 7 is an enlarged cross sectional view of the phonograph, showing the phonograph feed and the tilting shelf in end elevation, and Figs. 8, 9 and 10 are diagrams of the circuit connections.

tone VARYING ATTACHMENT FOR REPRODUCING NEEDLES.—Richard H. Vesey, Denver, Col. Patent No. 1,185,266.

This invention relates to improvements in means applied to the reproducing needles of talking machines and consists in equipping the needle holder with a number of pieces or blocks composed of substances varying in hardness or density, all of them preferably being of less density than metal of which the usual needle holder is composed.

In the improvement the needle holder is simply extended, the extension consisting of a hollow part which may be integral with the ordinary needle holding member, within which hollow part is located a number of members of varying density or hardness as heretofore stated. These members are perforated to register with the recess or socket of the ordinary needle holding part. The needle, if relatively loud results are required, should extend into the metal socket or recess of the ordinary metal part. When it is desired to vary the tone by making it lower or softer, the needle is withdrawn from the metal socket so that its inner extremity shall engage one of the members of the improvement. As these members themselves are of varying density or hardness, as many different primary or basic variations in tone may be obtained, as there are different members or substances employed. In the construction illustrated in the drawing there are shown three blocks or pieces, composed of different material from the metal holder, the said blocks or pieces also varying in density as compared with one another. Consequently four different primary tone variations may be obtained, one when the needle is in the socket of the metal holder, and others as the inner extremity of the needle is left within the other blocks or pieces of the improvement. Furthermore a great variety of sub-tone variations may be obtained by varying the distances which the needle pene-



trates any one of the said members. In order to vary the tone it is only necessary to adjust the needle by moving it outwardly or inwardly as may be required.

In the drawing, Figure 1 is a perspective view of a sound reproducing machine of the disk type, the needle holder being equipped with the improvement. Fig. 2 is a detail view of a needle and needle holder likewise equipped. Fig. 3

is a similar view showing a slightly modified form of construction. Fig. 4 is a sectional view in detail showing the improvement applied to a needle holder of ordinary construction, the latter being indicated by dotted lines. Fig. 5 is a similar view showing a slightly modified form of construction. Figs. 6 to 9 inclusive are detail sectional views showing the improved needle holder construction with the needle in different positions of adjustment, the parts being shown on a larger scale than in the other views.

LIGHT AND SOUND DISTRIBUTING APPARATUS.—George E. Emerson, Newark, N. J., assignor by Mesne assignments to Emerson Phonograph Co., Inc., New York. Patent No. 1,185,987.

This invention relates to light and sound distributing apparatus, and comprises means for producing sound waves, said sound waves coacting with the heat of light rays, produced by the appurtenances of the invention, and from which results a distribution of the said sound waves.

The invention assumes the form of a piece of artistic furniture, and specifically comprises a sound producing apparatus coacting with the heat resulting from a source of light, preferably a lamp, the lamp generally consisting of an electric bulb, although other sources of light may be used. The lamp is positioned to coact with the sound waves produced by the apparatus

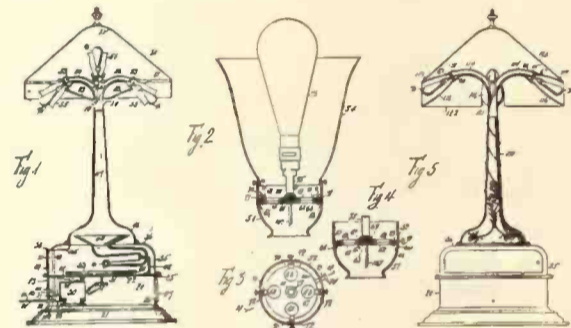

without interfering with the vibrations thereof.

Some of the forms in which the invention may be embodied are shown and described in this application, although the disposition of the elements shown, may be varied in numerous ways without departing from the invention.

The source of light or lamp of the invention is surrounded by an envelop of heated air, the hottest layer being adjacent to the lamp, and the temperature of the layers decreasing with their distance from the lamp. The velocity of sound increases with the temperature of the transmitting medium, the velocity increasing at about the rate of 23.9 inches with one degree centigrade. The end of the sound wave nearest to the lamp travels faster than the portion more distant from the lamp. The direction of advance of the sound wave before entering the

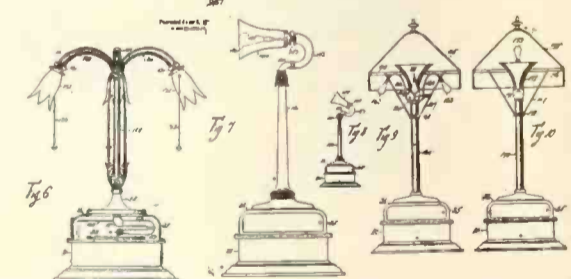

unequally heated mass of air surrounding the lamp is parallel to the axis of the lamp, and variably heated strata of air about the lamp cause a turning of the sound wave, so that the direction of advance thereof is diverged from the axis of the lamp, thereby producing a distribution of the sound waves.

In the various forms of the invention shown and described, in which the source of illumination consists of a lamp within the sound duct or horn of the apparatus, the lamp is separated or stepped off from the latter, so that the advance of the sound waves is not obstructed. When a lamp shade is used it is preferably made of a translucent material that will reverberate from the effects of the sound waves impinging thereon, and thereby perform the functions of a sound horn.

Referring to the accompanying drawings, Figure 1 represents an elevation and partial axial section of one form of the invention; Fig.

2 shows an enlarged fragmentary portion of Fig. 1; Fig. 3 is a top view of Fig. 2 with some of the elements omitted; Fig. 4 shows a section of Fig. 3 on the line 4-4; Fig. 5 represents an elevation and partial vertical axial section of a modification of the invention; Fig. 6 shows an elevation and partial axial section of a second modification of the invention; Fig. 7 shows an elevation of a third modification of the invention; Fig. 8 represents a modification of Fig. 7, and Figs. 9 and 10 show elevations of further modifications of the invention.

**SOUNDING BOARD FOR PHONOGRAPHS.**—Owen B. Williams, Seattle, Wash. Patent No. 1,186,869.

The object of this invention is to eliminate certain objectionable qualities in the sounds reproduced in talking machines, particularly such sounds as harsh and unnatural tones and the squeakiness or shrill character of sounds as sometimes produced. This comprises an improvement in the tonal qualities of the sounds reproduced making them a more correct reproduction of the original sounds.

Figure 1 is a vertical section taken through the rotative bell or table upon which the reproducing disc is supported while in use. Fig. 2 is a half plan view of one type of construction for the novel device which constitutes the invention. Fig. 3 is a like half plan view of the same member with slight modifications of structure, and Fig. 4 is a section showing in detail the construction of the supporting foot or projection.

**MEANS FOR MAKING AND REPRODUCING PHONOGRAPH RECORDS.**—Charles F. Winch, New York. Patent No. 1,187,119.

This invention relates to apparatus for use in connection with sound recording and reproducing machines and has to do more particularly with a means for taking up and transmitting the sounds to or from the stylus or needle which engages the record.

A principal object of the invention is to produce a greater amplitude of movement of the stylus in response to the vibrations set up by the speaker or singer than is possible by previous constructions and at the same time to secure an action of said stylus that shall follow positively and faithfully the vibrations produced by the speaker or singer whose voice is to be recorded.

Essentially this invention consists of a liquid holding receptacle having a diaphragm closing one wall or side thereof and of larger area than the stylus carrying diaphragm and having also a liquid outlet by which the body of liquid with which the diaphragm is in contact may be placed in communication with the diaphragm carrying the recording stylus or needle.

The preferred form of carrying out the invention is shown in the accompanying drawings wherein a horn like the ordinary sound gathering horn of a phonograph recorder or reproducer is shown constructed as a liquid tank with a sound receiving or producing diaphragm located in or near the mouth

of the same, suitable means being also provided for permitting the filling of the tank with a liquid. This particular form of the invention may be conveniently described as a phonograph tank horn.

The drawing shows this form of the invention in vertical central section.

**SOUND BOX FOR PHONOGRAPHS.**—Newman H. Holland, West Orange, N. J., assignor to the New Jersey Patent Co., same place. Patent No. 1,187,146.

This invention relates to sound boxes and more particularly to that part of a sound box which carries the diaphragm and the stylus. It

has heretofore been customary to mount the stylus of a recorder in an arm or lever disposed of at an angle with reference to the diaphragm and secured thereto both at the center and at the periphery thereof. This construction is objectionable in that the inclined stylus arm acts as a brace and thereby brakes or dampens the vibrations of the diaphragm.

It is the object to eliminate this objection by securing the stylus arm to the diaphragm in such a way that the portion of the said arm

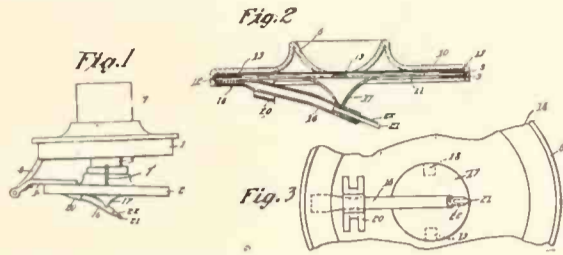

which is adjacent the periphery of the diaphragm will be movable with reference to the latter. Another object is to provide a new and improved means for securing the diaphragm to its support without the use of adhesives, screws or other similar fastening means.

Figure 1 is a side elevation of a recorder embodying the invention; Fig. 2 is a central, vertical section of the diaphragm support and the parts carried thereby, the diaphragm being shown in end elevation, and Fig. 3 is a bottom plan view partly broken away of the device shown in Fig. 2.

**SOUND REPRODUCING MACHINE.**—John C. English, Camden, N. J., assignor to the Victor Talking Machine Co., same place. Patent No. 1,187,892.

The main objects of this invention are, to provide a compact talking machine having actuating mechanism, and sound reproducing and sound amplifying mechanism inclosed within a casing; to provide a talking machine having sound reproducing mechanism, and a sound amplifier inclosed in a casing having an improved adjustable cover arranged to receive the sound waves delivered from the sound amplifier and to deflect the same in any desired direction; to provide a talking machine having a record support mounted within a casing, sound reproducing means and sound amplifying means arranged to co-operate with the record support, and supported within the casing from the rear wall thereof, the sound amplifying means having a delivery end opening upwardly beneath the plane of the record support; to provide a talking machine having a casing provided with an adjustable cover and improved means for holding the cover in adjusted position; to provide a

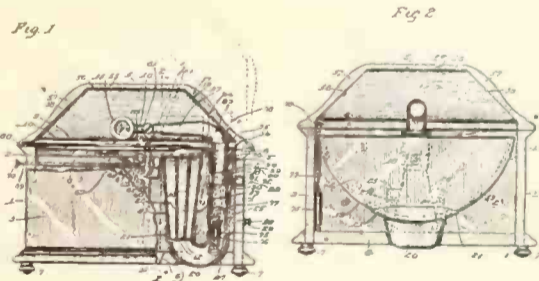

talking machine having a casing provided with a movable cover, and improved means for preventing the sudden closing of the cover; to provide a talking machine having a casing recessed internally to permit of the use of a relatively large record.

In the drawings, Figure 1 is a fragmentary side elevation partly in vertical section of a talking machine constructed in accordance with this invention, and Fig. 2 a transverse vertical section on line 2-2 of Fig. 1, looking in the direction of the arrows.

**SOUND BOX FOR TALKING MACHINES.**—Alva D. Jones, Philadelphia, Pa., assignor of one-half to John S. Latta, same place. Patent No. 1,188,079.

This invention consists of an attachment for the sound box in a talking machine by which such box constructed to be used with a record having its sound groove laterally waved, can be adapted to be employed with a record of the "hill and valley" type.

It further consists of means for supporting

such a sound box in a horizontal plane instead of in a vertical plane from the tone arm; for attaching a tube extension between the sound box and the tone arm to present the former in the proper position to the record; means for preventing relative rotation of the box upon its support and the dislocation of the stylus.

In the annexed drawings, Figure 1 represents a side elevation of the end of the tone arm, of a gooseneck and sound box of a talking machine embodying the invention. Fig. 2 represents a plan view of a talking machine having the invention applied to it. Fig. 3 represents a section on the line x-x in Fig. 1. Fig. 4 represents a plan view of the sound box and stylus mechanism. Fig. 5 represents a detail view of the tone intensifying elements. Fig. 6 represents a detail view of a detachable form of such elements. Fig. 7 represents a perspective detail

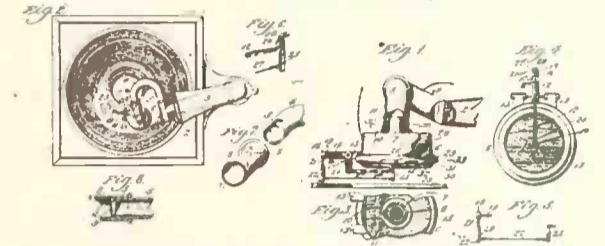

view of the end of the gooseneck and of the sound box tube, detached from each other. Fig. 8 represents an axial section of such parts when joined.

**SOUND REPRODUCING MACHINE.**—John C. English, Camden, N. J., assignor to the Victor Talking Machine Co., same place. Patent No. 1,188,374.

The main objects of this invention are, to provide a compact talking machine having actuating mechanism, and sound reproducing and sound amplifying mechanism inclosed within a casing; to provide a talking machine having sound reproducing mechanism and a sound amplifier inclosed in a casing having an improved adjustable cover arranged to receive the sound waves delivered from the sound amplifier and to deflect the same in any desired direction; to provide a talking machine having an amplifier provided with an upwardly opening delivery end and inclosed in a casing having an adjustable cover arranged to deflect the sound waves delivered by the amplifier and to throw the same forwardly in any desired direction; to provide a talking machine having an amplifier with a delivery end inclosed in a casing provided with an adjustable cover arranged to deflect the sound waves delivered by the amplifier, and having an adjustable damper or closure arranged adjacent the delivery end of the amplifier to vary the quantity of sound waves directed against the deflecting surface of the cover of the casing, and thus modify the intensity of the sound waves delivered by the talking machine; to provide a talking machine inclosed in a casing having a movable cover and improved means for holding the cover in position of adjustment; to

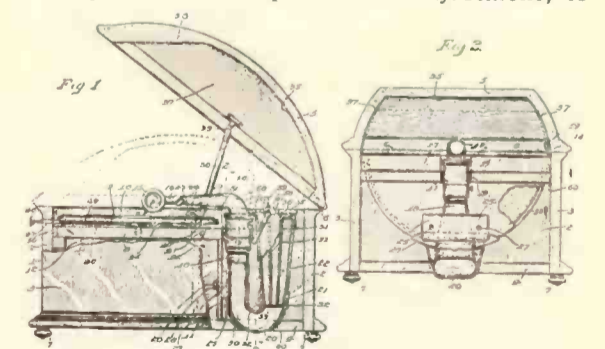

provide an improved sound amplifier; to provide sound modifying means for a sound amplifier.

In the drawings, Figure 1 is a fragmentary side elevation, partly in vertical section, of a talking machine constructed in accordance with this invention, and Fig. 2 is a fragmentary transverse vertical section partly in elevation on line 2-2 of Fig. 1 looking in the direction of the arrows.

M. T. Abernathy has purchased an interest in the business of Kors & Meinhardt, of Independence, Kans., Edison Diamond Disc dealers, the firm now being known as Abernathy, Kors & Meinhardt.

RECORD BULLETINS FOR SEPTEMBER, 1916.

COLUMBIA GRAPHOPHONE CO.

- BLUE-LABEL DOUBLE-DISC RECORDS**  
*Popular Songs*
- A2039 Keep a Place Down in Your Heart for Ireland (Von Tilzer). Tenor Solo, orch. accompaniment. De Los Becker 10  
Welcome, Honey, to Your Old Plantation Home (Gumble). Orch. accompaniment, Peerless Quartet 10
- A2045 On the South Sea Isle (Von Tilzer). Orch. accompaniment. Sterling Trio 10  
I Lost My Heart in Honolulu (Edwards). Orch. accompaniment. Sterling Trio 10
- A2046 America Prepare! (Day). Orch. accompaniment, Broadway Quartette 10  
Medley of American Patriotic Airs (arr. by Maurice Smith), Introducing "America," "Yankee Doodle," "Columbia, the Gem of the Ocean," "Marching Through Georgia," Prince's Band 10
- A2038 By the Sad Luana Shore (Goetz). Tenor Duet, Orch. accompaniment, Albert Campbell-Henry Burr 10  
Come Back to Arizona (Paley). Tenor-Baritone Duet, Orch. accompaniment, Reed Miller-Frederick D. Wheeler 10
- A2037 Johnny Get a Girl (Puck). Baritone-Tenor Duet, Orch. accomp., Arthur Collins-Byron G. Harlan 10  
If You Love Your Girl in the Summertime (Piantadosi). Baritone-Tenor Duet, Orch. accomp., Arthur Collins-Byron G. Harlan 10
- A2043 Oh, How She Could Yacki Hacki Wicki Yacki Woo (That's Love in Honolulu) (Von Tilzer). Tenor Solo, Orch. accomp., G. Harlan 10  
Some Girls Do and Some Girls Don't (Johnson-Gerber-Jentes). Baritone Solo, Orch. accomp., Oscar Shaw 10
- A2042 Suzanne (Carroll). Soprano Solo, Orch. accomp., Anna Wheaton 10  
I Didn't Know That Lovin' Was So Good (Von Tilzer). Soprano Solo, Orch. accomp., Anna Wheaton 10
- A2040 If I Knock the "L" Out of Kelly (It Would Still be Kelly to Me) (Grant). Soprano Solo, Orch. accomp., Marguerite Farrell 10  
The Greatest Battle Song of All (Ruby). Tenor Solo, Orch. accomp., Irving Kaufman 10
- A2044 There's Someone More Lonesome Than You (Von Tilzer). Tenor-Baritone Duet, Orch. accomp., James Reed-James F. Harrison 10  
Don't Leave Me, Daddy (Verges). Baritone Solo, Orch. accomp., Arthur Fields 10
- A2041 You're a Dangerous Girl (Monaco). Orch. accomp., Al Jolson, comedian 10  
On the Old Dominion Line (Botsford). Orch. accomp., Peerless Quartette 10
- DOUBLE-DISC RECORDS**  
*Dance Records of the Month*
- A5837 Down Where the Swanee River Flows (Von Tilzer). Fox-trot. Prince's Band 12  
I Sent My Wife to the Thousand Isles (Von Tilzer). (a) "It's a Hundred to One You're in Love," (b) "Pretty Please." One-step, Prince's Band 12
- A5836 Your Wife (Piantadosi). Introducing "Let My Dream Come True." One-step. Prince's Band 12  
On Your Way (MacClure). One-step, Prince's Band 12
- A5838 Missouri Waltz (From an original melody procured by J. C. Appel, arranged by F. K. Logan). Prince's Orchestra 12  
The Waltz We Love (Vecsey) Prince's Orchestra 12
- BLUE-LABEL DOUBLE-DISC RECORDS**  
*Two Hymns by Mixed Quartette*
- A2030 Holy God We Praise Thy Name (Ritter). Orch. accomp., Columbia Mixed Quartette 10  
Mother Dear, Oh Pray for Me. Orch. accomp., Columbia Mixed Quartette 10
- A2032 Manzanillo (Mexican Dance) (Robyn, arr. by Recker). Prince's Orchestra 10  
Sunshine and Roses (Rolfe). A Novelette, Prince's Orchestra 10
- A2033 Manna Kea—Medley. Hawaiian Guitar Duet, Helen Louise and Frank Ferera 10  
That Ukulele Band (Granville). Hawaiian Guitar Duet, Helen Louise and Frank Ferera 10
- A2034 Hill and Dale (Lodge). Syncopated Fox-trot. Banjo, Saxophone and Piano. Van Eps Trio 10  
Daly's Reel (Daly). Banjo, Saxophone and Piano. Van Eps Trio 10
- A2035 I Keep On Toddling Along (Rule and Pelham). Orch. accomp., Billy Williams, comedian 10  
I'll Have to Ask My Mother (Williams and Godfrey). Orch. accomp., Billy Williams, comedian 10
- A2036 Medley of Irish Jigs. Introducing "Haste to the Wedding," "Larry O'Gaff" and "The Smash." Joe Linder at the Piano, John J. Kimmel, Accordion 10  
Medley of Irish Reels. Introducing "Bonnie Kate," "Swallow Tail," "Star of Munster." Joe Linder at the Piano, John J. Kimmel, Accordion 10
- DOUBLE-DISC RECORDS**  
*Master Overture Masterfully Played*
- A5829 Tannhäuser—Overture (Wagner). Part 1, Prince's Symphony Orchestra 12  
Tannhäuser—Overture (Wagner). Part 2, Prince's Symphony Orchestra 12
- SYMPHONY DOUBLE-DISC RECORDS**  
*Graveure's Art at Its Height*
- A2047 Flow Thou Regal Purple Stream (Arnold). Baritone Solo. Louis Graveure 10  
Tommy Lad! (Margetson). Baritone Solo, Louis Graveure 10
- A5831 Etude, Op. 25, No. 3, in "F" Major and Prelude, Op. 28, No. 16, in "B" Flat Minor (Chopin). Piano Solo, Vladimir De Pachmann 12  
Polonaise—Cadenza (Liszt). Piano Solo, Vladimir De Pachmann 12
- A5835 Lohengrin. In Fernem Land (In Distant Lands). Lohengrin's Narrative (Wagner). Tenor Solo, in German, with orchestra, Johannes Sembach 12  
Die Walküre, Siegmund's Liebeslied (Siegmund's Love Song), Winter Sturme Wichen Den Wonnemond (Now Winter Storms Are Waning) (Wagner). Tenor Solo, in German, with orchestra, Johannes Sembach 12
- A5839 Do You Remember? (Carrie Jacobs-Bond). Baritone Solo, Orch. accomp., Oscar Seagle 12  
A Perfect Day (Carrie Jacobs-Bond). Baritone Solo, Orch. accomp., Oscar Seagle 12
- DOUBLE-DISC RECORDS**
- A5441 On the Road to Mandalay (Speaks). Basso Solo, Orch. accomp., Frank Croton 12  
Father O'Flynn (Arranged by Stanford). Basso Solo, Orch. accomp., Frank Croton 12
- A5636 Hunting Tower (When Ye Gang Awa' Jamie). Soprano-Tenor Duet, Orch. accomp., Grace Kerns-Illary McClaskey 12

- Land of the Swallows (Masini). Contralto-Tenor Duet, Orch. accomp., Mildred Potter-John Barnes Wells 12
- A5677 Espana Rhapsody (Chabrier). Prince's Orchestra 12  
Ballet Egyptian (Luigini). Prince's Orchestra 12
- A5703 Scenes Pittoresques (Massenet). Angelus, Prince's Orchestra 12  
Scenes Pittoresques (Massenet). Fete Bohème. Prince's Orchestra 12
- A1547 Gone Are the Days. Tenor Solo, Orch. accomp., Charles Harrison 10  
I'm Coming Back to Dixie and You (Lyons, Yosco and Mullane). Orch. accomp., Peerless Quartette 10
- A1678 Answer (Robyn). Tenor Solo, Orch. accomp., Reed Miller 10  
Blue Alsatian Mountains (Adams). Soprano Solo, Orch. accomp., Grace Kerns 10
- A5749 Casse-Noisette Suite (Tschaiowsky). Danse Chinoise and Danse des Mirlitons, Prince's Orchestra 12  
Casse-Noisette Suite (Tschaiowsky). Valse des Fleurs, Prince's Orchestra 12
- A1914 Second Regiment C. N. G. March (Reeves), Prince's Band 10  
Washington Post March (Sousa). Prince's Band 10
- A5710 Absent (Metcalfe). Soprano Solo. In English, with orchestra, Madame Corinne Rider-Kelsey 12  
A Dream (Bartlett). Soprano Solo. In English, with orchestra, Madame Corinne Rider-Kelsey 12
- E2852 Wanderlied (Wanderer Song). In German, with orchestra, Max Bloch, Tenor Metropolitan Opera 10  
O Bitt Euch, Liebe Vögelein (You Merry Birds). In German, with orchestra, Max Bloch, Tenor Metropolitan Opera 10
- E2860 Longing for Our Country, Russian Balalaika Orchestra 10  
Song of the Volga Boatmen, Russian Balalaika Orchestra 10
- E2861 Butterfly Waltz (Andreeff), Russian Balalaika Orchestra 10  
Bright Shines the Moon (Andreeff), Russian Balalaika Orchestra 10
- E2863 The Lundby Waltz (Johnson). Accordion Duet, Lager and Olson 10  
Norwegian Peasant Waltz. Accordion Duet, Lager and Olson 10
- E2844 Nad Beronnkou Pod Tetinem (On the Hill Near Tetine). In Bohemian, with orchestra, Erma Zárska, Soprano Metropolitan Opera 10  
Andulko, Mě Dítě (Annie, My Child). In Bohemian, with orchestra, Erma Zárska, Soprano Metropolitan Opera 10
- E2867 Manon Lescaut (Puccini). "La Madrigale," Mezzo-Soprano and Chorus. In Italian, with orchestra, E. Lopez-Nunes 10  
Manon Lescaut (Puccini). "Ahl non v'avvicinate." Tenor Solo. In Italian, with orchestra, Cav. E. Garbin 10
- E2868 La Forza Del Destino (Verdi). (The Force of Destiny) "Del mondo i disinganni." Baritone-Basso Solo. In Italian, with orchestra, F. Corradetti-V. Bettoni 10  
La Forza Del Destino (Verdi). "Urna fatale." Baritone Solo. In Italian, with orchestra, D. Caporello 10

VICTOR TALKING MACHINE CO.

- POPULAR SONGS FOR SEPTEMBER**
- 18088 You're a Dangerous Girl (from "Robinson Crusoe, Jr.") (Grant Clarke-Jimmie V. Monaco), Avon Comedy Four 10  
I'm Going Way Back Home and Have a Wonderful Time (Jerome Schwartz), Avon Comedy Four 10
- 18089 I'm Saving Up the Means to Get to New Orleans (Howard Johnson-Harry de Costa), Collins and Harlan 10  
My Lovin' Lou (James Kendis), Collins and Harlan 10
- 18100 He's the Makin's of a Darn'd Fine Man (Will Mahoney-Otto E. Herman), Ada Jones 10  
When Priscilla Tries to Reach High C (Jack Mahoney-Harry Von Tilzer), Ada Jones-Billy Murray 10
- 18101 On Lake Champlain (Alfred Bryan-Albert Gumble), Sterling Trio 10  
Dear Old Dreamy Honolulu Town (Farran-Brannen-Rega-Lange), Peerless Quartet 10
- 18102 Pretty Baby (from "Passing Show of 1916" produced at the Winter Garden) (Kahn-Jackson-Van Alstyne), Billy Murray 10  
When You Drop Off At Cairo, Illinois (from "Step This Way") (E. Ray Goetz-Cliff Hess), Bill Murray 10
- 18103 It's Always Orange Day in California (from "Canary Cottage"), Peerless Quartet 10  
I Never Knew (from "Canary Cottage") (Earl Carroll), Edna Brown-James Reed 10
- 18104 I Left Her on the Beach at Honolulu (from "Ziegfeld Follies—1916") (Gene Buck-Louis A. Hirsch), Harry Macdonough and Mixed Chorus 10  
Have a Heart (from "Ziegfeld Follies—1916") (Gene Buck-Jerome D. Kern), Alice Green-Raymond Dixon 10
- 18107 Uncle Sammy's Army (M. H. Morse-H. M. Dolph), James F. Harrison 10  
Old Glory (A Song of Preparedness (Edwin Skedden-Katherine Pike), Herbert Stuart 10
- 18105 If I Knock the "L" Out of Kelly (from Lew Fields' "Step This Way") (Lewis-Young-Grant), Marguerite Farrell and Chorus 10  
By the Sad Luana Shore (from Lew Fields' "Step This Way") (E. Ray Goetz), Marguerite Farrell and Chorus 10
- DANCE RECORDS**
- 17980 The Globe Trot (Crudup Vesey), Victor Military Band 10  
La Czarine—Three-step (Mazurka Russe) (Louis Ganne), Victor Military Band 10
- 17981 Mi Ricurita—Tango (Osman Perez Freire), Victor Dance Orchestra 10  
El Amanecer—Tango (Roberto Firpo), Victor Dance Orchestra 10
- 18106 Two-Key Rag—Fox trot (Joe Hollander) (Patrick Conway, Director), Conway's Band 10  
The Harlequin—One-step (Chas. J. Roberts) (Patrick Conway, Director), Conway's Band 10
- 35535 Love's Spell—Three-step (Mazurka) (Ed. Strauss), Victor Military Band 12  
Varsoviana ("See My New Shoes") (Allen Dодworth) (Patrick Conway, Director), Conway's Band 12
- 35571 Have a Heart—Medley fox trot (from "Ziegfeld Follies—1916") (Patrick Conway, Director), "Have a Heart"—"I Left Her" on the Beach at Honolulu—"Bachelor Days," Conway's Band 12
- Welcome Honey to Your Old Plantation Home—Medley one-step (Patrick Conway, Director), "Welcome Honey to Your Old Plantation Home"—"On the Old Dominion Line"—"She's Good Enough to be Your Baby's Mother"—

- "Everybody Loves a Little Bit of Irish," Conway's Band 12
- MISCELLANEOUS INSTRUMENTAL RECORDS**
- 17941 Pagliacci—Vesti la giubba (On with the Play) (Leoncavallo) (Accordion Solo), Pietro Cavalleria Rusticana—Intermezzo (Mascagni) (Four Piano Accordions), Pietro's Accordion Quartet 10  
18049 Minuet (Boccherini) (Violin-Flute-Cello-Harp), Florentine Quartet 10  
Träumerei (Schumann) (Violin-Flute-Cello-Harp), Florentine Quartet 10
- 18057 Mo-Ana (Hawaiian Waltz) (Olsen) (Mandolins and Guitar), Athenian Mandolin Quartet 10  
Cacliz March (Ballig), Athenian Mandolin Quartet 10
- 18060 Remembrance of Gatschina—Valse (Andreeff), Imperial Russian Balalaika Court Orchestra 10  
On the Wings of Song (Mendelssohn), Imperial Russian Balalaika Court Orchestra 10
- 18085 Ragging the Scale—Fox trot (Claypoole) Banjo Solo, Fred Van Eps 10  
Eldorado March (Victor Herbert) (Xylophone Solo), William H. Reitz 10
- 18087 Maui Aloha—One-step (Hawaiian Guitars), Helen Louise-Frank Ferera 10  
Pua Carnation (Hawaiian Guitars), Helen Louise-Frank Ferera 10
- 18097 Pussyfoot March (In Fox Trot Time) ("Slap" White) (Saxophone Sextette), Six Brown Brothers 10  
Bull Frog Blues (In Fox Trot Time) (Browne-Shringley), Six Brown Brothers 10
- 35564 Blue Danube Waltz (Johann Strauss), Hurtado Bros. Royal Marimba Band 12  
Southern Roses Waltz (Rosas del Sur) (Johann Strauss), Hurtado Bros. Royal Marimba Band 12
- 18083 The Mocking Bird (Winner) (Whistling Solo), Frank Haffort 10  
Tout Passe Waltz (Berger) (Whistling Solo), Guido Gialdini 10
- PIPE ORGAN RECORDS**
- 35547 Hallelujah Chorus (from "The Messiah") (Handel), Reginald L. McAll 12  
Funeral March (Chopin), Richard K. Biggs 12
- VOCAL RECORDS**
- 35568 Songs of the Past—No. 15—Chorus, "O Dem Golden Slippers" (Bland)—Chorus and Male Quartet, "Darling Nellie Gray" (Hanby)—Chorus, "Shine On" (Schoolcraft)—Solo and Male Quartet, "Carry Me Back to Old Virginia" (Bland)—Solo and Male Quartet, "Zip Coon"—Solo and Male Quartet, "Ise Gwine Back to Dixie" (White)—Chorus, "In the Morning by the Bright Light" (Bland), Victor Mixed Chorus 12
- Songs of the Past—No. 16—Chorus, "Oh! Susanna"—Solo and Mixed Quartet, "Old Dog Tray"—Solo and Male Quartet, "Nelly Bly"—Solo and Male Quartet, "Come Where My Love Lies Dreaming"—Solo and Mixed Quartet, "Hard Times"—Chorus, "Camptown Races" (Stephen C. Foster), Victor Mixed Chorus 12
- 35566 Scrooge—Part 1—"Marley's Ghost" (Monologue arranged from "A Christmas Carol") (Dickens), William Sterling Battis 12  
Scrooge—Part 2—"The Ghost of Christmas Past" (Monologue arranged from "A Christmas Carol") (Dickens), William Sterling Battis 12
- 35567 Scrooge—Part 3—"The Ghost of Christmas Present" (Monologue arranged from "A Christmas Carol") (Dickens), William Sterling Battis 12  
Scrooge—Part 4—"The Ghost of Christmas to Come" (Monologue arranged from "A Christmas Carol") (Dickens), William Sterling Battis 12
- 18086 (1) Bible Reading—Luke 2 (2) A Christmas Carol (J. G. Holland), Harry E. Humphrey 10  
(1) It Came Upon the Midnight Clear (Willis) (2) Hark! the Herald Angels Sing (Mendelssohn) (3) Joy to the World (Handel), Victor Concert Orchestra 10
- 17870 Joseph Mine (Berühmtes Weihnachtslied) (Calvisius—A. D. 1587), Victor Mixed Chorus 10  
(1) Lo, How a Rose E'er Blooming (2) To Us Is Born Immanuel (M. Praetorius—A. D. 1609), Lyric Quartet 10
- BLUE AND PURPLE LABEL RECORDS**
- 45093 Lichesfreud (Old Vienna Waltz) (Kreislser), Charles Kellogg, "The Nature Singer" and Victor Orchestra 10  
Pas des Amphores (Air de Ballet, No. 2) (Chaminade), Charles Kellogg, "The Nature Singer" and Victor Orchestra 10
- 45100 For Dixie and Uncle Sam (Brennan-Ball), Nora Bayes 10  
Homesickness Blues (Cliff Hess), Nora Bayes 10
- 60141 Doughie the Baker (It's Nicer When You Make It Up Again) (Lauder-MacFayden), Harry Lauder 10
- RED SEAL RECORDS**
- EMMA CALVE, Soprano—in French  
88570 La Marseillaise (with the Metropolitan Opera Chorus), Rouget de L'Isle 12
- ENRICO CARUSO, Tenor—in French  
88556 La Procession, Ch. Brizeux-César Franck 12
- GERALDINE FARRAR, Soprano  
87248 Lead, Kindly Light, Cardinal J. H. Newman-Rev. J. B. Dykes 10  
JOHANNA GADSKI, Soprano—in German  
88566 Haidenröslein (Hedge Rose) (with String Quartet), Goethe-Werner 12
- MABEL GARRISON, Soprano—in French  
74489 Mignon—Polonaise (Je suis Titania (I'm Fair Titania!) (Act II), Ambrose Thomas 12
- EMILIO DE GOCORZA, Baritone  
64584 Pagliacci—Prologue in Italian, Leoncavallo 10  
64598 Je sais que vous êtes jolie (I Feel I'm in Love) in French, H. Poupon Christine 10
- ALMA GLUCK, Soprano—in English  
64591 The Bird of the Wilderness (Text from "The Gardener" by Rabindranath Tagore), Horsman 10
- LOUISE HOMER, Contralto—in English  
87259 Last Night, Halfdan Kjerulf 10  
87255 Oh, Promise Me (from "Robin Hood"), deKoven 10
- FRITZ KREISLER, Violinist  
64600 Rondino (On a theme by Beethoven) (with String Quartet), Kreisler 10
- JOHN McCORMACK, Tenor—FRITZ KREISLER, Violinist—in English  
(Pianoforte by Edwin Schneider)  
87245 Tales of Hoffmann—Barcarolle ("Belle Nuit"—Oh Night of Love), Offenbach 10
- MAUD POWELL, Violinist  
(Piano accompaniment by Arthur Loesser)  
64611 Molly on the Shore (Irish Reel), Setting by Percy Grainger 10
- CLARENCE WHITEHILL, Baritone  
64602 Marching Through Georgia, Henry C. Work 10

THOS. A. EDISON, INC.

- NEW EDISON DIAMOND DISC RECORDS**
- 50350 All Aboard for Chinatown (Brookhouse), Arthur Collins and Byron G. Harlan 10  
I Can Dance With Everybody But My Wife—Sybil (Golden), Tenor Solo, Billy Murray 10
- 50352 My Bonnie, Bonnie Jean (Lauder), Glen Ellison 10  
Nanny, I Have Never Loved Another Girl But You (Lauder), Glen Ellison 10

50353 Kangaroo Hop—Fox-trot (Morris). Nxylophone,  
Lou Chiha "Frisco"  
Setting the Pace—One-step (Chester W. Smith).  
For Dancing.....Jaudas' Society Orchestra  
50355 Sybil Fox-trot (When Cupid Calls (Jacobi). For  
Dancing.....Jaudas' Society Orchestra  
Sybil Waltz (Jacobi). For Dancing,  
Jaudas' Society Orchestra  
83045 I Am a Roamer Bold ("Son and Stranger")  
(Mendelssohn). Basso Solo....Arthur Middleton  
Spring Morning. Soprano Solo.....Julia Heinrich

**EDISON BLUE AMBEROL RECORDS**

**CONCERT LIST**

28241 Gigue, Rust; and Pierrrot—Serenade (Alberto  
Randegger, Jr.). Violin, piano acc. by André  
Benoist.....Albert Spalding

**REGULAR LIST**

2942 Are You from Dixie? ("Cause I'm From Dixie  
Too) (George L. Cobb). Tenor, orch. accomp.,  
Billy Murray and Chorus  
2957 Baby Shoes (Al. Piantadosi). Soprano Solo.  
Orch. accomp.....Elizabeth Spencer  
2948 Don't Bite the Hand That's Feeding You  
(Jimmie Morgan). Tenor Solo. Orch. ac-  
comp.....Walter Van Brunt  
2940 If I Knock the "L" Out of Kelly (It Would Still  
Be Kelly to Me) (Grant-Lewis-Young). Orch.  
accomp.....Ada Jones and Chorus  
2954 She Sang "Aloha" to Me (Joseph B. Carey)  
Tenor Solo. Orch. accomp.,  
Walter Van Brunt and Chorus  
2949 So Long Letty (Earl Carroll). Contralto and  
Baritone Duet. Orch. accomp.,  
Helen Clark and Joseph A. Phillips  
2962 Sweet Cider Time, When You Were Mine  
(Percy Wenrich). Baritone Solo. Orch. ac-  
comp.....Joseph A. Phillips  
(Introducing Helen Clark in the Refrain)  
2953 There's a Quaker Down in Quaker Town (Alfred  
Solman). Baritone, orch. accomp.,  
Joseph A. Phillips

**SONGS AND BALLADS**

2946 My Bonnie, Bonnie Jean (Harry Lauder). Orch.  
accomp.....Glen Ellison  
2951 My Grandfather's Girl (Will Dillon). Tenor,  
orch. accomp.....George Wilton Ballard  
2955 Spirit Flower (Campbell-Tipton). Tenor, orch.  
accomp.....Emory B. Randolph  
2959 When Irish Eyes Are Smiling—The Isle o'  
Dreams (Ernest R. Ball). Tenor, orch. ac-  
comp.....Walter Van Brunt

**BANDS AND ORCHESTRAS**

2958 Chateau Three-Step (Will Donaldson). For  
dancing.....Jaudas' Society Orchestra  
2947 Marcia Roma (Musso).....Createore and His Band  
2950 Missouri Waltz (Logan-Eppel). For dancing,  
Jaudas' Society Orchestra

2961—On the Hoko Moko Isle Medley—One-step. For  
dancing.....Jaudas' Society Orchestra

**INSTRUMENTAL HITS**

2956 Hapa Haole Hula Girl (Sonny Cunha). Ha-  
waiian Guitars....Helen Louise and Palakiko Ferreira  
2944 Keep Off the Grass (Harry Von Tilzer). Banjo,  
orch. accomp.....Vess L. Ossman  
2941 Medley of Hawaiian Airs—No. 2. Hawaiian  
Guitars....Helen Louise and Palakiko Ferreira  
2943 Love-Sick Coon. Vaudeville Sketch with Banjo.  
Billy Golden and James Marlowe  
2945 Serenade (Schubert). Cornet with orch.  
Ernst Albert Couturier  
2052 Winter Song. Male Voices, unaccomp.  
Criterion Quartet

2963 Story of the Little Red Hen; and Little Maud's  
Story. Bed-time Stories.....Alice Goddard

**FRENCH RECORDS**

27176 Le Pere la Victoire (Louis Ganne). Baritone,  
orch. accomp.....Orpheus Langevin  
27177 Le Saint Laurent (Xavier Mercier). Baritone,  
orch. accomp.....Orpheus Langevin

**SWEDISH RECORDS**

9445 National Air of Sweden....New York Military Band  
9444 Sockerdricka (Kuplett). Baritone, orch. accomp.  
Charles G. Widdén

**PATHE FRERES PHONOGRAPH CO.**

82001 Goyescas, "La Maja y el Ruisenor" (Granados).  
Sung in Spanish.  
Anna Fitziu, Soprano, orch. accomp. 14

Ave Maria (Gounod). (In English).  
Anna Fitziu, Soprano, Violin, Harp, Organ  
accomp. Violin Obligato..... 14

62011 Maria, Mari (Neapolitan Song) (Di Capua).  
Sung in Italian.  
Lina Cavalieri, Soprano, orch. accomp. 12

So 'turnato (Neapolitan Song) (Cassesse and  
Falve). Sung in Italian.  
Lina Cavalieri, Soprano, orch. accomp. 12

52004 Aria Fresca (Fresh Air) (Nardella). Sung in  
Italian....Hugh Allan, Baritone, orch. accomp. 12

Canta Pa Luna (Song to the Moon) (Nardella).  
Sung in Italian.  
Hugh Allan, Baritone, orch. accomp. 12

**NEW VOCAL FOREIGN RECORDS**

80069 Rigoletto "Et sa voix" (Verdi). Duet.  
Vallandri, Soprano, Noté, Baritone, orch. acc. 14

Rigoletto "Quartette" (Verdi).  
Vallandri, Soprano; Lapeyrette, Contralto,  
Lasalle, Tenor; Noté, Baritone..... 14

62013 La Juive, "Rachel, quand der Seigneur" (Hal-  
evy). In French. Guitar, Tenor, orch. accomp. 12

Mignon, "Air de Titania" (Polonaise) (Thomas).  
Sung in French.  
Marguerite Charpentier, Soprano, orch. accomp. 12

62014 Aida "Duet Act III" "Aida-Amonasro" Part I  
(Verdi). Sung in Italian.  
E. Magliulo, Soprano; Montesanto, Baritone 12

Aida "Duet Act II" "Aida-Amonasro" (Part  
II (Verdi). Sung in Italian.  
E. Magliulo, Soprano; Montesanto, Baritone 12

62016 Lohengrin "Du armste" (Thou Unhappy One)  
(Wagner). Duet, sung in German.  
Erna Denera, Soprano; Thela Plaichinger,  
Soprano, orch. accomp. .... 12

Lohengrin "Wenn ich im Kampfe" (When in  
Battle) (Wagner). Duet.  
Erna Denera, Soprano; Hans Tanzler, Tenor 12

62018 Manon "Duo de la lettre" (Letter Duet) (Mas-  
senet). In French.  
Vallandri, Soprano; Vaguet, Tenor, orch. acc. 12

Manon "Duo de la rencontre" (Duet Act I).  
In French.  
Vallandri, Soprano; Vaguet, Tenor, orch. acc. 12

62019 Lucia di Lammermoor "D'un amour qui me  
brave" (Cruda funesta) (Donizetti). In  
French.....Noté, Baritone, orch. accomp. 12

Rigoletto "Courtisans race vile et damnee" (Vice  
Race of Courtiers) (Verdi). In French.  
Albers, Baritone, orch. accomp. 12

62020 La Bohème "Musetta Waltz Song" (Puccini).  
In Italian....A. Billi, Soprano, orch. accomp. 12

The Pearl Fishers "Temer non so per me" (I  
Fear Not) (Bizet). In Italian.  
Edvige Medugno, Soprano, orch. accomp 12

**NEW FRENCH SONGS**

22001 Le P'tit Objet (Scott-Christine). In French.  
Par Polin, orch. accomp. 10

Les Petites Compensations (Spencer). In  
French.....Par Polin, orch. accomp. 10

30338 L'Ame Des Violons (Rene de Buxeuil). Valse  
Tzigane.....Par Junka, avec orchestre 12

Ferme Tes Jolie Yeux (Rene de Buxeuil). Ber-  
ceuse.....Par Junka, avec orchestre 12

30339 La P'tite Lilie (E. Gavel). Chanson vecue.  
Par Marcelly, avec orchestre 12

Florella (E. Desmoulines). Chanson venitienne.  
Par Marcelly, avec orchestre 12

30340 Rendez-moi Mes Vingt Ans (E. Gavel). Valse  
populaire.....Par Marcelly, avec orchestre 12

Les Grognards Passent (Sablon). Chanson.  
Par Marcelly, avec orchestre 12

30344 L'Echo Tyrolien (St. Servans).  
Par Charlesky, avec orchestre 12

Chevrier, Chante (Thoulouze) Tyrolienne.  
Par Charlesky, avec orchestre 12

30348 Mariage au Oiseaux (P. Lincke).  
Par Fragon, avec piano 12

Je Connais Une Blonde (Goetz et Sloane). Chan-  
sonnette sur les motifs de la nouvelle danse  
Americaine.....Par Fragon, avec piano 12

30361 Pour Toi (Codini-Courtioux). Valse Chantee.  
Par Berard, avec orchestre 12

Je serai-la (Codini).  
Par Berard, avec orchestre 12

50011 On the Road to Mandalay (Kipling and Speaks).  
Wallace Cox, Baritone, orch. accomp. 12

Out on the Deep (Cowen and Lohr).  
James Stanley, Basso, orch. accomp. 12

40042 Ever of Thee (Hall).  
Carrie Herwin, Contralto, orch. accomp. 12

When Twilight Comes (Strelezki).  
Carrie Herwin, Contralto, orch. accomp. 12

40041 Lo, Here the Gentle Lark (Wm. Shakespeare  
and Bishop).  
Lillian Heyward, Soprano, orch. accomp. 12

The Fairy Flute.  
Rosina Buckman, Soprano, orch. accomp. 12

40039 Drink to Me Only with Thine Eyes (Old Eng-  
lish Melody) (Jonson).  
Wallace Cox, Baritone, orch. accomp. 12

Friend of Mine (Sanderson).  
Thorpe Bates, Baritone, orch. accomp. 12

40036 The Holy City (Weatherley and Adams).  
James Stanley, Basso, orch. accomp. 12

I Love to Tell the Story (Hanks and Fischer).  
Stanley Mixed Quartette, organ accomp. 12

35022 Where the River Shannon Flows (Russell).  
Harry McClaskey, Tenor, orch. accomp. 12

West Country Song "Devon for Me" (Kahn).  
Harry Reynolds, Basso, orch. accomp. 12

35050 I Come frae Scotland (Godfrey and Williams).  
Billy Williams, Comedian, orch. accomp. 12

Mister John MacKenzie O (Godfrey and Will-  
iams). Billy Williams, Comedian, orch. accomp. 12

35024 There's a Quaker Down in Quaker Town (Bal-  
lad) (Solman and Berg).  
Alfred Alexander and Frank Webster, orch. acc. 12

Morning, Noon and Night (White).  
Louis J. Wunsch, Baritone, orch. accomp. 12

20005 All I Want Is a Cottage, Some Roses and You  
(Chas. K. Harris).  
Campbell and Burr, orch. accomp. 10

At the End of a Beautiful Day (Wm. H. Per-  
rins).....Henry Burr, Tenor, orch. accomp. 10

20006 If I Find the Girl, from "Very Good, Eddie"  
(Hazzard, Reynolds and Kern).  
Louis J. Wunsch, Baritone, orch. accomp. 10

My Grandfather's Girl, from "Jane O'Day from  
Broadway" (W. A. Dillon).  
Louis J. Wunsch, Baritone, orch. accomp. 10

**VOCAL SPECIALTIES WITH BIRD EFFECTS**  
20008 The Old Rustic Bridge by the Mill (Skelly), with  
Bird Effects.  
Arthur George, Baritone, orch. accomp. 10

The Song of the Thrush (Le Brun), with Bird  
Effects. Arthur George, Baritone, orch. accomp. 10

**NEW FOREIGN INSTRUMENTAL RECORDS**

35047 Glorious and Courageous Allies (Anon.).  
Garde Republicaine Band of France 12

Bulgarian Hymn (Anon.).  
Garde Republicaine Band of France 12

35048 The Return from the Battle, Part I (Anon.).  
Garde Republicaine Band of France 12

The Return from the Battle, Part II (Anon.).  
Garde Republicaine Band of France 12

35049 Samson and Delila (Saint-Saens) Fantasic, Part  
I. ....Garde Republicaine Band of France 12

Samson and Delila (Saint-Saens) Fantasic, Part  
II. ....Garde Republicaine Band of France 12

**NEW HAWAIIAN RECORDS—VOCAL AND INSTRUMENTAL**

35044 Amina (Paul Lincke) Intermezzo.  
Louise Ferera Hawaiian Troupe 12

Portuguese Tango (Played by the Composers).  
Louise Ferera Hawaiian Troupe 12

35045 My Own Iona (Gibert, Friedland and Morgan).  
Henry Burr, Louise and Ferera Hawaiian Or-  
chestra Accompaniment ..... 12

Waikiki Mermaid (Sonny Cunha).  
Louise and Ferera Hawaiian Troupe. 12

**OPERAPHONE MANUFACTURING CORP.**

1601 Fox-trot—Globe-trot (Roberts)....Operaphone Band  
Hail to the Spirit of Liberty—March (Souza),  
Operaphone Band

1803 I'm Falling in Love with Someone (from  
"Naughty Marietta") (Herbert)...Charles Harrison  
Beauty's Eyes (Tosti).....Charles Harrison

1904 Listen to That Dixie Band (Yellen-Cobb),  
Collins & Harlan

Any Rags (Allen).....Arthur Collins  
1085 Never Let the Same Bee Sting You (from  
"Very Good, Eddie") (Mack-Smith). Arthur Collins  
Stormy Sea of Love (MacDonald-Carroll),  
M. J. O'Connell

1086 I've Got a Sweet Tooth Bothering Me (Berlin),  
M. J. O'Connell

Baby Shoes (Piantadosi).....Louise Mertens  
1087 If I Knock the "L" Out of Kelly, Sure He'd  
Knock the "L" Out of Me (Bert Grant). Dan Quinn

At the Fountain of Youth (Jentes).....Dan Quinn  
1088 The Ashes of My Heart (Branen-Lange). Carl Bergen  
Forgotten (Cowles).....Carl Bergen

1089 Whispering Hope (Hawthorne),  
Sue Harvard and Louise Mertens

My Laddie (Scotch Low Song) (Thayer). Sue Harvard  
1090 Along the Rocky Road to Dublin—One-step (Bert  
Grant) .....Dance Orchestra

Mighty Lak' a Rose—Waltz.....Dance Orchestra  
1091 Babes in the Wood (from "Very Good, Eddie")  
Fox trot (Kern).....Dance Orchestra

Southern Roses—Waltz (Strauss)...Dance Orchestra  
1092 At Dawning (Eberhardt-Cadman).....Carl Bergen  
The Nightingale.....Sue Harvard

**EMERSON PHONOGRAPH CO.**

**7-INCH EMERSON DOUBLE DISCS  
POPULAR SONG HITS OF THE MONTH—ORCHESTRA  
ACCOMPANIMENT**

757 Arrah Go On, I'm Gonna Go Back to Oregon.  
Tenor Solo .....Samuel Ash  
My Gal Sal. Tenor Solo.....Manuel Romain

764 If I Knock the "L" Out of Kelly. Comic Song.  
Dan Quinn  
Some Little Bug Is Going to Find You. Comic  
Song.....Dan Quinn

763 Auf Wiedersehn, from Musical Comedy "Blue  
Paradise." Soprano and Tenor Duet.  
Grace Nash and Samuel Ash

Somewhere a Voice Is Calling. Baritone Solo.  
Herbert Morley

760 At the End of a Beautiful Day. Tenor Solo.  
Samuel Ash

All I Want Is a Cottage, Some Roses and You.  
Tenor Solo.....Manuel Romain

759 I've Got the Army Blues. Baritone Solo.  
Morton Harvey

The Old Flag Never Touched the Ground. Tenor  
Solo .....Manuel Romain

765 Rackety-Coo, from Musical Comedy "Katinka".  
Soprano and Tenor Duet.  
Grace Nash and Samuel Ash

Trail to Sunset Valley. Tenor Solo. Manuel Romain  
**POPULAR DANCE RECORDS**

762 Whistler and His Dog.....Emerson Military Band  
Second Regiment Connecticut March.  
Emerson Military Band

761 Wee Bit o' Scotch. Fox-trot. Emerson Military Band  
Up the Street. March and One-step.  
Emerson Military Band

**STANDARD AND MISCELLANEOUS SELECTIONS**  
758 Believe Me, If All Those Endearing Young  
Charms. Tenor Solo with orch. accomp.  
Henry Burr

Oh, Promise Me. Tenor Solo, with orch. accomp.  
Henry Burr

755 Charge of the Light Brigade. Dramatic Recita-  
tion, accomp. by Bugle.....Harry Humphrey  
Barbara Frietchie. Dramatic Recitation, accomp.  
by Fifes and Drums.....Harry Humphrey

756 Seven Ages of Man. Recitation from Shakes-  
peare's "As You Like It".....Harry Humphrey  
Shylock's Justification of the Jew. Recitation  
from Shakespeare's "Merchant of Venice."  
Harry Humphrey

**READY REFERENCE OF GENERAL SUPPLIES**

**DEALERS**

Send for our "Trial Proposition" on the  
Regina Hexaphone—the latest and best pay-  
ing popular priced coin-operated instrument  
for use in public places.



211 Marbridge Bldg., 34th St. and Broadway, New York City  
Manufacturers of Regina Music Boxes; Reginaphones;  
Coin-operated Mandolin Orchestrions; Vacuum  
Cleaners and other specialties.

**NEEDLES**

WE MANUFACTURE

Diamond needles for Edison  
Sapphire needles for Edison  
Sapphire needles for Pathe  
in stock ready for delivery

MERMOD & CO., 505 5th Ave., N. Y.

**Keep Your Record Stock with**



Costs about \$2.00 for 250 records for 50 years  
Send for 20-page catalog

**THE SYRACUSE WIRE WORKS,  
SYRACUSE NEW YORK**

# Leading Jobbers of Talking Machines in America

**SERVICE FIRST**  
 EXCLUSIVE VICTOR JOBBERS  
 WHOLESALE ONLY  
**Standard Talking Machine Co.**  
 PITTSBURGH, PA.

**Victor Exclusively**  
 EASTERN TALKING MACHINE CO.  
 177 Tremont Street, Boston  
 VICTOR DISTRIBUTORS

**Sherman, Clay & Co.**  
 San Francisco, Los Angeles, Portland, Seattle, Spokane  
 PACIFIC COAST DISTRIBUTORS  
 Victrolas and Victor Records, Steinway Pianos, Pianola  
 Pianos, Holton Band Instruments

**Southern Victor Dealers**  
 Largest Stock VICTROLAS and RECORDS.  
 Prompt Shipment and Low Freight Rates.  
**WALTER D. MOSES & CO.**  
 Oldest Music House in Virginia or North Carolina.  
 RICHMOND, VA.

**OLIVER DITSON COMPANY**  
 BOSTON  
 Largest VICTOR Talking Machine Distributors East of Chicago.  
 Creators of "The Fastest Victor Service." Let us tell you more about our service.

**The Chicago Edison Jobber**  
 The perfection of musical Instruments—THE EDISON diamond disc PHONOGRAPH—with EDISON double disc records.  
 THE PERFECTION OF SERVICE—Our Service.  
 The Perfection of advertising for the dealer—Our plan.  
**The PHONOGRAPH CO.**  
 229 So. Wabash Ave., CHICAGO

**W. J. DYER & BRO.**  
 Saint Paul, Minn.  
**VICTOR & EDISON**  
 Distributors  
 Quick Service for all points in the Northwest. Machines, Records, Supplies.

1856 **WURLITZER** 1916  
**VICTOR**  
 DISTRIBUTORS  
 VICTORS EXCLUSIVELY  
*We make a specialty of getting the order out on time—every time.*  
**The Rudolph Wurlitzer Co.**  
 CINCINNATI AND CHICAGO  
 Two points of supply; order from the nearer

**GATELY-HAIRE CO., Inc.**  
*If it's Victor, we have it  
 We have it if it's Victor*  
 ALBANY, N. Y.

**The PERRY B. WHITSIT CO.**  
 Distributors of  
 Victrolas and Victor Records  
 COLUMBUS, OHIO

*Pathephone*  
 PACIFIC COAST DISTRIBUTORS  
 322 Post Street San Francisco

**Cressey & Allen**  
 Victor Distributors  
 Portland Maine  
 C. & A. SERVICE THE BEST

EVERY JOBBER IN THIS COUNTRY SHOULD BE REPRESENTED IN THIS DEPARTMENT. THE COST IS SLIGHT AND THE ADVANTAGE IS GREAT. BE SURE AND HAVE YOUR CARD IN THIS DEPARTMENT OF THE TALKING MACHINE WORLD.

## AUTO FOR GRUNEWALD SERVICE

This New Orleans Piano House Purchases Studebaker Truck for Delivery of Grafonolas

NEW ORLEANS, LA., July 29.—The L. Grunewald Co., of this city, is utilizing the most modern ideas in retail wareroom equipment in order that its patrons may receive efficient service and co-operation. In this connection the com-



The Grunewald Delivery Truck  
 company recently purchased a Studebaker truck which is used exclusively for the distribution of Columbia Grafonolas and records to its customers in this city and the outlying suburbs. It is proving an invaluable aid to the store's general delivery system, and the service it is rendering has won considerable praise from the Grunewald Columbia clientele. The words "Columbia Grafonolas and Records" appear in bold lettering on the side of the truck, forming an effective advertisement for these products.

It may be mentioned, incidentally, that Columbia graphophones and records are well ad-

vertised in this city, a large painted bulletin board on St. Charles avenue featuring the famous Columbia "Note the Notes" trade-mark, with the names and addresses of some of the local Columbia dealers.

## TALKING MACHINE EXPORTS

The Figures for May Presented—Exports Show Increase for the Month

WASHINGTON, D. C., July 29.—In the summary of the exports and imports of the commerce of the United States for the month of May, 1916 (the latest period for which it has been compiled), which has just been issued by the Bureau of Statistics of the Department of Commerce and Labor, the following figures relating to talking machines and supplies are set forth:

Talking machines to the number of 4,162, valued at \$117,517, were exported for May, 1916, as compared with 2,456 talking machines, valued at \$79,987, sent abroad in the same month of 1915. The total exports of records and supplies for May were valued at \$73,968, as compared with \$75,432 in May, 1915. For the eleven months 36,819 talking machines were exported, valued at \$1,081,815, and records and supplies valued at \$867,795 were sent abroad for that period.

## OPENING NEW STORE

John Lindemod is installing a music shop adjacent to the Campbell jewelry store, at Osawatomie, Kan., where a full line of Victor Victrolas and Edison Diamond Disc machines will be carried.

## A GO-AHEAD MT. VERNON STORE

The accompanying photograph shows the handsome interior of the phonograph store of the Arcade Phonograph Corp., Mt. Vernon,



Salesrooms of Arcade Phonograph Corp. N. Y., of which A. Stephenson is president and treasurer. This house is a representative of the Columbia, Sonora and Victor talking machines and in its territory is considered to be quite a live organization.

## FRANK SAMUEL VISITS COLUMBIA CO.

Frank Samuel, general manager of Barnett Samuel & Sons, Ltd., London, Eng., was a visitor last week at the offices of the Columbia Graphophone Co., New York, whose products his concern handles as a distributor. Mr. Samuel spoke enthusiastically of the Columbia business his house is closing, stating that their sales to date have exceeded all expectations. He visited the Columbia factory at Bridgeport, Conn., and was greatly impressed with the same.



## What Would YOU Rather Have?

THE agency for a phonograph which is sold at every store, or the agency for the Sonora which is restricted to the best dealers in any locality—*which?*

THERE is a tremendous demand for Sonoras from all over the world. The excellence of *each machine sold, sells others*. The advertising of Sonora is steady and aggressive.

IF you handle the Sonora you offer for sale the instrument which won the *highest score for tone quality* at the recent San Francisco Exposition, in competition with every

phonograph and talking machine worth mentioning.

WE suggest that if you feel that you are able to do justice to the sale of a product of such acknowledged and proved superiority as is Sonora—we suggest that you write us.

THE demands of our present dealers are making our production department exert itself to the last notch, but we are looking ahead to the future.

THE fact that each month breaks the preceding month's record for sales should make you think.

Sonora, the most perfect phonograph in existence, is what the *public wants to buy*

*Do you want to sell it?*

Ten magnificent models

Each, at its price, *the world's finest phonograph*

\$45   \$60   \$75   \$100   \$150   \$175   \$190   \$225   \$350   \$1000

**SONORA PHONOGRAPH CORPORATION**

GEORGE E. BRIGHTSON, President

Main Offices and Salesrooms, 57 Reade Street, NEW YORK

Mid-Western Office, 320 South Wabash Avenue, CHICAGO, ILL.

Western Office, 344 Geary Street, SAN FRANCISCO, CAL.

*Representatives throughout the country*

# “EDISON”

The Stamp of Genius

and—

the mark of a dealer  
policy that gives  
the merchant  
licensed to sell  
the *New  
Edison*  
every



CHIPPENDALE  
Official Laboratory Model



ADAM  
Model C200



SHERATON  
Without Inlay  
Model C150



MODERNE  
Model A100

oppor-  
tunity to  
demonstrate  
that no more  
dealers are nec-  
essary within his  
zone of operations  
in order to secure the  
maximum results from  
that zone.

THOMAS A. EDISON, Inc.  
279 Lakeside Avenue Orange, N. J.

## JOBBER OF EDISON PHONOGRAPHS AND RECORDS

CALIFORNIA  
Los Angeles—Diamond Disc Distributing Co.  
San Francisco—Pacific Phonograph Co.

COLORADO  
Denver—Denver Dry Goods Co.

CONNECTICUT  
New Haven—Pardee-Ellenberger Co.

GEORGIA  
Atlanta—Phonographs, Inc.

ILLINOIS  
Chicago—The Phonograph Co.

INDIANA  
Indianapolis—Kipp Phonograph Co.

IOWA  
Des Moines—Harger & Blish.  
Sioux City—Harger & Blish.

LOUISIANA  
New Orleans—Diamond Music Co., Inc.

MASSACHUSETTS  
Boston—Pardee-Ellenberger Co.

MICHIGAN  
Detroit—Phonograph Co., of Detroit.

MINNESOTA  
Minneapolis—Laurence H. Lucker.

MISSOURI  
Kansas City—The Phonograph Co. of Kansas City.

St. Louis—Silverstone Music Co.

MONTANA  
Helena—Montana Phonograph Co.

NEBRASKA  
Omaha—Shultz Bros.

NEW YORK  
Albany—American Phonograph Co.  
New York—The Phonograph Corp. of Manhattan.  
Syracuse—Frank E. Bolway & Son, Inc.

OHIO  
Cincinnati—The Phonograph Co.  
Cleveland—The Phonograph Co.

OREGON  
Portland—Pacific Phonograph Co.

PENNSYLVANIA  
Philadelphia—Girard Phonograph Co.  
Pittsburgh—Buehn Phonograph Co.  
Williamsport—W. A. Myers.

TEXAS  
Dallas—Texas-Oklahoma Phonograph Co.  
El Paso—El Paso Phonograph Co., Inc.

UTAH  
Ogden—Proudfit Sporting Goods Co.

VIRGINIA  
Richmond—C. B. Haynes & Co.

WASHINGTON  
Seattle—Pacific Phonograph Co., N.W.  
Spokane—Pacific Phonograph Co.

WISCONSIN  
Milwaukee—The Phonograph Co. of Milwaukee.

CANADA  
Montreal—R. S. Williams & Sons Co., Ltd.

St. John—W. H. Thorne & Co., Ltd.  
Toronto—R. S. Williams & Sons Co., Ltd.

Vancouver—Kent Piano Co., Ltd.  
Winnipeg—R. S. Williams & Sons Co., Ltd.

Calgary—R. S. Williams & Sons Co., Ltd.